

**APPLICATION OF
LONE STAR TRANSMISSION, LLC
TO AMEND ITS CERTIFICATE OF CONVENIENCE
AND NECESSITY FOR THE
PROPOSED REATA STATION TO ROADRUNNER
CROSSING WIND 345 KV TRANSMISSION LINE
IN EASTLAND COUNTY**



DOCKET NO. 50910

Submit seven (7) copies of the application and all attachments supporting the application. If the application is being filed pursuant to 16 Tex. Admin. Code § 25.101(b)(3)(D) (TAC) or 16 TAC § 25.174, include in the application all direct testimony. The application and other necessary documents shall be submitted to:

**Public Utility Commission of Texas
Attn: Filing Clerk
1701 N. Congress Ave.
Austin, Texas 78711-3326**

Application of Lone Star Transmission, LLC to Amend Its Certificate of Convenience and Necessity for the Proposed Reata Station to Roadrunner Crossing Wind 345 kV Transmission Line in Eastland County

1. Applicant (Utility) Name: Lone Star Transmission, LLC

Certificate Number: 30196

Street Address: 5920 W. William Cannon Dr., Bldg. 2
Austin, TX 78749

Mailing Address: 5920 W. William Cannon Dr., Bldg. 2
Austin, TX 78749

2. Please identify all entities that will hold an ownership interest or an investment interest in the proposed project but which are not subject to the Commission's jurisdiction.

Not applicable. Lone Star Transmission, LLC (Lone Star) will construct and hold the sole ownership interest in the facilities associated with the proposed Reata Station to Roadrunner Crossing Wind 345 kilovolt (kV) Transmission Line in Eastland County (Project).

3. Person to Contact: Stacie Bennett
Title/Position: Director, Regulatory Affairs
Phone Number: (512) 236-3135
Mailing Address: 5920 W. William Cannon Dr., Bldg. 2
Austin, TX 78749
Email Address: stacie.bennett@lonestar-transmission.com

Alternate Contact: Kelly Wells
Title/Position: Director, Land Strategy and Community Relations
Phone Number: (512) 236-3151
Mailing Address: 5920 W. William Cannon Dr., Bldg. 2
Austin, TX 78749
Email Address: kelly.wells@lonestar-transmission.com

Legal Counsel: Tracy Davis, Senior Attorney
Phone Number: (512) 236-3141
Mailing Address: 5920 W. William Cannon Dr., Bldg. 2
Austin, TX 78749
Email Address: tracy.davis@lonestar-transmission.com

Application of Lone Star Transmission, LLC to Amend Its Certificate of Convenience and Necessity for the Proposed Reata Station to Roadrunner Crossing Wind 345 kV Transmission Line in Eastland County

4. Project Description:

Name or Designation of Project

Proposed Reata Station to Roadrunner Crossing Wind 345 kV Transmission Line in Eastland County (Project)

Provide a general description of the project, including the design voltage rating (kV), the operating voltage (kV), the CREZ Zone(s) (if any) where the project is located (all or in part), any substations and/or substation reactive compensation constructed as part of the project, and any series elements such as sectionalizing switching devices, series line compensation, etc. For HVDC transmission lines, the converter stations should be considered to be project components and should be addressed in the project description.

Design Voltage Rating (kV): 345 kV

Operating Voltage (kV): 345 kV

CREZ Zone(s): Not applicable

Substation(s) Included: Reata 345 kV Station (Reata Station)

Series Element(s) Included: None

Lone Star is proposing to design and construct the proposed Project to interconnect the new Roadrunner Crossing Wind generation facility being constructed by Roadrunner Crossing Wind Farm, LLC (Roadrunner Crossing Wind), a subsidiary of RWE. The proposed transmission line will be constructed as an approximately 2.3-mile, single-circuit 345 kV transmission line on primarily concrete monopoles that will extend from Roadrunner Crossing Wind's 345 kV collector station (Collector Station), located at the intersection of County Road (CR) 125 and CR 126 near Putnam, Texas, to Lone Star's proposed Reata Station. The proposed Reata Station will be cut into Lone Star's existing West Shackelford to Sam Switch 345 kV Transmission Line, near the intersection of CR 126. The proposed transmission line will require a 100- to 150-foot right of way (ROW).

Lone Star is proposing one consensus route (Consensus Route) for the Project because the two directly affected landowners have provided their written agreement to the Consensus Route. In addition, the Consensus Route is a forward-progressing and relatively direct path from the Roadrunner Crossing Wind Collector Station to the proposed Reata Station that meets the applicable criteria of the Public Utility Regulatory Act (PURA) and the Commission's rules in 16 Texas Administrative Code (TAC) § 25.101. Therefore, this Application sets forth a single proposed Consensus Route for the Project.

If the project will be owned by more than one party, briefly explain the ownership arrangements between the parties and provide a description of the portion(s) that will be owned by each party. Provide a description of the responsibilities of each party for implementing the project (design, Right-of-Way acquisition, material procurement, construction, etc.).

Not applicable. Lone Star will own 100 percent of the Project described in this Application.

If applicable, identify and explain any deviation in transmission project components from the original transmission specifications as previously approved by the Commission or recommended by a PURA § 39.151 organization.

Not applicable. The Commission has not previously approved, and the Electric Reliability Council of Texas (ERCOT) (a PURA § 39.151 organization) has not previously recommended, any transmission specifications applicable to this project.

Application of Lone Star Transmission, LLC to Amend Its Certificate of Convenience and Necessity for the Proposed Reata Station to Roadrunner Crossing Wind 345 kV Transmission Line in Eastland County

ERCOT Nodal Protocol § 3.11.4 (relating to Transmission Planning) and the ERCOT RPG Charter and Procedures define a project that interconnects new generation as a “neutral project” that does not require ERCOT Regional Planning Group (RPG) review. Therefore, the proposed Project was not submitted for RPG review, and ERCOT did not provide any transmission specifications for the Project. Thus, there are no deviations from the original transmission specifications previously recommended by ERCOT.

In accordance with the Nodal Protocols, ERCOT did perform a Generation Interconnect Screening Study, which concluded that the proposed generation facility could be interconnected into Lone Star’s West Shackelford to Sam Switch 345 kV Transmission Line. Additionally, Lone Star completed the Full Interconnection Study process required by ERCOT, which included a Facility Study. The Facility Study describes the transmission facilities and associated costs required to interconnect the new generation project. The Facility Study was available to ERCOT and other transmission service providers (TSP) for review and comment for 10 days, and Lone Star received no comments.

5. Conductor and Structures:

Conductor Size and Type

The conductor used for the Project will be a twin-bundled 795kcmil ACSR “Drake” conductor with a single 0.530 Optical Guy Wire and 7/#7 overhead shield wire.

Number of Conductors Per Phase

The Project will be constructed with two conductors per phase.

Continuous Summer Static Current Rating (A)

The nominal Continuous Summer Static Current Rating for the Project is 1800 Amps (A).

Continuous Summer Static Line Capacity at Operating Value (MVA)

The nominal Continuous Summer Static Line Capacity at Operating Voltage for the Project is 1080 Megavolt Amps (MVA).

Continuous Summer Static Line Capacity at Design Voltage (MVA)

The nominal Continuous Summer Static Line Capacity at Design Voltage for the Project is 1080 MVA.

Type and composition of Structures

The Project will be constructed primarily using self-supporting, single-circuit concrete monopole structures. Alternative structure types, such as concrete guyed dead-end monopole structures, may be used outside of Lone Star’s Reata Station and the Roadrunner Crossing Wind Collector Station.

Height of Typical Structures

The typical structure height for the Project will be approximately 90 to 120 feet. However, the height may vary depending on the clearance requirements at a particular location due to the terrain, span lengths, overhead obstructions, and various other constraints.

Estimated Maximum Height of Structures

The maximum height of structures will be approximately 120 feet above ground.

Application of Lone Star Transmission, LLC to Amend Its Certificate of Convenience and Necessity for the Proposed Reata Station to Roadrunner Crossing Wind 345 kV Transmission Line in Eastland County

Explain why these structures were selected; include such factors as landowner preference, engineering considerations, and costs comparisons to alternate structures that were considered. Provide dimensional drawings of the typical structures to be used in the project.

Lone Star selected concrete monopoles for the Project because they have shorter fabrication lead times and are generally more cost-effective compared to other structure types. In addition, Lone Star's spare inventory includes pre-stressed concrete monopoles.

Further, based on Lone Star's general experience, many landowners also prefer monopoles because they have a reduced structure footprint, which generally results in fewer impacts to land and reduces interference with current land uses, *i.e.*, ranching and farming.

Dimensional drawings of the concrete monopole structures are included as Figures 1-2 and 1-3 of the *Environmental Assessment of the Proposed Reata Station to Roadrunner Crossing Wind 345 kV Transmission Line Project in Eastland County, Texas* (EA), prepared by Lone Star's routing consultant, Burns & McDonnell Engineering Company, Inc. (Burns & McDonnell), and included as Attachment 1 to this Application.

For joint applications, provide and separately identify the above-required information regarding structures for the portion(s) of the project owned by each applicant.

Not applicable. This is not a joint application.

6. Right-of-way:

Miles of Right-of-Way

The total miles of ROW for the Consensus Route filed by Lone Star is approximately 2.3 miles in length.

Miles of Circuit

The Project will be a single-circuit transmission line, and thus, the number of circuit miles for the Consensus Route is approximately 2.3 miles.

Width of Right-of-Way

The typical ROW for the Project will be 100 to 150 feet in width.

Percent of Right-of-Way Acquired

None of the ROW (0%) has been acquired by Lone Star at this time. Roadrunner Crossing Wind is currently in the process of acquiring the necessary easements from the two impacted landowners along the Consensus Route. The easements will be transferred to Lone Star once the CCN is approved. The two impacted landowners crossed by the Consensus Route have granted their written consent for the Consensus Route, and these written consents are provided in Attachment 2 to this Application.

For joint applications, provide and separately identify the above-required information for each route for the portion(s) of the project owned by each applicant.

Not applicable. This is not a joint application.

Application of Lone Star Transmission, LLC to Amend Its Certificate of Convenience and Necessity for the Proposed Reata Station to Roadrunner Crossing Wind 345 kV Transmission Line in Eastland County

Provide a brief description of the area traversed by the transmission line. Include a description of the general land uses in the area and the type of terrain crossed by the line.

The area traversed by the transmission line is located within the North-Central Plains Physiographic Province, which occurs in the north-central portion of the State. The proposed Consensus Route is located in northwestern Eastland County, approximately six miles west-northwest of the City of Cisco, which serves as the county seat. No incorporated city nor unincorporated community is located within the Study Area. The Study Area is located within a rural portion of the county and is dominated by agricultural fields, rangeland, and mesquite shrubland. Very few isolated residences and farmsteads are located in the Study Area. The landscape consists of level to rolling mesquite-covered plains, dissected by a few eroded breaks and streambeds. Elevations within the relatively flat to gently rolling Study Area range from a high of approximately 1,616 feet above mean sea level (msl) in the south-central portion of the Study Area to a low of 1,459 feet above msl in the northwestern corner.

Specific discussion regarding natural, human, and cultural resources in the Study Area is presented in Section 3 of the EA (Attachment 1 of this Application).

7. Substations or Switching Stations:

List the name of all existing HVDC converter stations, substations or switching stations that will be associated with the new transmission line. Provide documentation showing that the owner(s) of the existing HVDC converter stations, substations and/or switching stations have agreed to the installation of the required project facilities.

Not applicable.

List the name of all new HVDC converter stations, substations or switching stations that will be associated with the new transmission line. Provide documentation showing that the owner(s) of the new HVDC converter stations, substations and/or switching stations have agreed to the installation of the required project facilities.

The proposed transmission line will extend between the new Reata Station and the Roadrunner Crossing Wind Collector Station. Lone Star will own the new Reata Station. The generator, Roadrunner Crossing Wind, will own the new Roadrunner Crossing Wind Collector Station.

8. Estimated Schedule:

<u>Estimated Dates of:</u>	<u>Start</u>	<u>Completion</u>
<i>Right-of-way and Land Acquisition</i>	May 1, 2020	June 30, 2021 or earlier depending on date of PUCT approval
<i>Engineering and Design</i>	May 20, 2020	December 31, 2020
<i>Material and Equipment Procurement</i>	August 1, 2020	August 1, 2021
<i>Construction of Facilities</i>	February 22, 2021	September 15, 2021
<i>Energize Facilities</i>	September 15, 2021	September 30, 2021

Although the estimated schedule assumes approval of the CCN will take a full one year, an earlier approval could provide several benefits to the ERCOT system, and ultimately ratepayers. For example, an earlier approval may provide Lone Star with more flexibility in taking the outages required to accommodate the interconnect. Flexibility in timing outages could allow Lone Star to optimize its outages (*i.e.*, take outages in coordination with other projects), and possibly minimize the total number of outages. Minimizing

Application of Lone Star Transmission, LLC to Amend Its Certificate of Convenience and Necessity for the Proposed Reata Station to Roadrunner Crossing Wind 345 kV Transmission Line in Eastland County

outages will provide less disruption to Lone Star's other transmission service customers, and to the ERCOT system overall. Finally, an earlier approval could allow for an earlier synchronization date, which could provide the transmission service customer with increased flexibility to test and commission its generation facility.

9. Counties:

For each route, list all counties in which the route is to be constructed.

The Consensus Route for the Project is located entirely within Eastland County.

10. Municipalities:

For each route, list all municipalities in which the route is to be constructed.

The Consensus Route for the Project is not located within the incorporated boundaries of any municipality.

For each applicant, attach a copy of the franchise, permit or other evidence of the city's consent held by the utility, if necessary or applicable. If franchise, permit, or other evidence of the city's consent has been previously filed, provide only the docket number of the application in which the consent was filed. Each applicant should provide this information only for the portion(s) of the project which will be owned by the applicant.

Not applicable.

11. Affected Utilities:

Identify any other electric utility served by or connected to facilities in this application.

No other electric utility is served by or directly connected to this Project.

Describe how any other electric utility will be affected and the extent of the other utilities' involvement in the construction of this project. Include any other utilities whose existing facilities will be utilized for the project (vacant circuit positions, ROW, substation sites and/or equipment, etc.) and provide documentation showing that the owner(s) of the existing facilities have agreed to the installation of the required project facilities.

Not applicable.

12. Financing:

Describe the method of financing this project. For each applicant that is to be reimbursed for all or a portion of this project, identify the source and amount of the reimbursement (actual amount if known, estimated amount otherwise) and the portion(s) of the project for which the reimbursement will be made.

Funds for the Project will come from Lone Star's existing cash on hand, existing debt facility, and owner equity.

Application of Lone Star Transmission, LLC to Amend Its Certificate of Convenience and Necessity for the Proposed Reata Station to Roadrunner Crossing Wind 345 kV Transmission Line in Eastland County

13. Estimated Costs:

Provide cost estimates for each route of the proposed project using the following table. Provide a breakdown of "Other" costs by major cost category and amount. Provide the information for each route in an attachment to this application.

<u>Consensus Route Costs</u>	Transmission Facilities	Substation Facilities
<i>Right-of-way and Land Acquisition</i>	\$170,000	\$120,000
<i>Engineering and Design (Utility)</i>	\$0	\$0
<i>Engineering and Design (Contract)</i>	\$90,000	\$600,000
<i>Procurement of Material and Equipment (including stores)</i>	\$620,000	\$8,740,000
<i>Construction of Facilities (Utility)</i>	\$0	\$0
<i>Construction of Facilities (Contract)</i>	\$2,340,000	\$12,100,000
<i>Other (all costs not included in the above categories)</i>	\$200,000	\$0
Estimated Total Cost	\$3,420,000	\$21,560,000

For joint applications, provide and separately identify the above-required information for the portion(s) of the project owned by each applicant.

Not applicable. This is not a joint application.

14. Need for the Proposed Project:

For a standard application, describe the need for the construction and state how the proposed project will address the need. Describe the existing transmission system and conditions addressed by this application. For projects that are planned to accommodate load growth, provide historical load data and load projections for at least five years. For projects to accommodate load growth or to address reliability issues, provide a description of the steady state load flow analysis that justifies the project. For interconnection projects, provide any documentation from a transmission service customer, generator, transmission service provider, or other entity to establish that the proposed facilities are needed. For projects related to a Competitive Renewable Energy Zone, the foregoing requirements are not necessary; the applicant need only provide a specific reference to the pertinent portion(s) of an appropriate commission order specifying that the facilities are needed. For all projects, provide any documentation of the review and recommendation of a PURA §39.151 organization.

The proposed Project is necessary to interconnect and provide transmission service to a new transmission service customer, Roadrunner Crossing Wind. Pursuant to 16 TAC §§ 25.191(d)(3) and 25.198(b), a TSP is required to provide service to a transmission service customer when certain conditions are met, including execution of an interconnection agreement. Roadrunner Crossing Wind requested an interconnection to Lone Star's existing West Shackelford to Sam Switch 345 kV Transmission Line. As a power generation company, Roadrunner Crossing Wind will qualify as a transmission service customer under 16 TAC § 25.5(140). Lone Star and Roadrunner Crossing Wind executed the ERCOT Standard Generation Interconnection Agreement on April 17, 2020 (Interconnection Agreement). The Interconnection Agreement was filed with the Commission in Project No. 35077 on April 27, 2020 and is included in this Application as Attachment 3.

Application of Lone Star Transmission, LLC to Amend Its Certificate of Convenience and Necessity for the Proposed Reata Station to Roadrunner Crossing Wind 345 kV Transmission Line in Eastland County

Additionally, 16 TAC § 25.195(c)(1) provides as follows: “When an eligible transmission service customer requests transmission service for a new generation source that is planned to be interconnected with a TSP’s transmission network, the transmission service customer shall be responsible for the cost of installing step-up transformers to transform the output of the generator to a transmission voltage level and protective devices at the point of interconnection capable of electrically isolating the generation source owned by the transmission service customer. The TSP shall be responsible, pursuant to paragraph (2) of this subsection, for the cost of installing any other interconnection facilities that are designed to operate at a transmission voltage level and any other upgrades on its transmission system that may be necessary to accommodate the required transmission service.” The Interconnection Agreement provided as Attachment 3 specifies and assigns these responsibilities pursuant to 16 TAC § 25.195(c)(1).

The ERCOT Nodal Protocols and ERCOT RPG Charter and Procedures define a project that is directly associated with the interconnection of new generation as a “neutral project,” which is not required to be submitted for RPG review. Since the Project was not submitted for RPG review, there is no documentation of a review or recommendation of ERCOT, a PURA § 39.151 organization.

In accordance with the Nodal Protocols, ERCOT performed a Generation Interconnect Screening Study, which concluded that the proposed generation facility could be interconnected into Lone Star’s West Shackelford to Sam Switch 345 kV Transmission Line. Additionally, Lone Star completed the Full Interconnection Study process required by ERCOT for all generation interconnection requests, which included a Facility Study. The Facility Study describes the transmission facilities and associated costs required to interconnect the new generation project. The Facility Study was available to ERCOT and other TSPs for review and comment for 10 days, and Lone Star received no comments.

15. Alternatives to Project:

For a standard application, describe alternatives to the construction of this project (not routing options). Include an analysis of distribution alternatives, upgrading voltage or bundling of conductors of existing facilities, adding transformers, and for utilities that have not unbundled, distributed generation as alternatives to the project. Explain how the project overcomes the insufficiencies of the other options that were considered.

Lone Star is proposing this Project in order to provide service to a transmission service customer, Roadrunner Crossing Wind, which has requested to interconnect its 200 MW wind generation facility to Lone Star’s existing West Shackelford to Sam Switch 345 kV Transmission Line. Other alternatives to the proposed Project would not provide a feasible or cost-effective solution to this identified project need.

First, using distribution facilities to transfer 200 MW from the generation facility to the existing 345 kV transmission system is not practical from an engineering or cost perspective. ERCOT typically requires generators larger than 10 MW to interconnect at transmission-level voltages (*i.e.*, above 60 kV). Second, there is no need for Lone Star to upgrade the voltage on its transmission facilities or add transformers. Roadrunner Crossing Wind requested to interconnect at 345 kV, which is the voltage level of Lone Star’s existing West Shackelford to Sam Switch 345 kV Transmission Line. Third, there is also no need for Lone Star to bundle conductors, as its existing transmission facilities already utilize bundled conductor. Finally, Lone Star is an unbundled, transmission-only utility, and therefore, distributed generation is not an alternative to the proposed Project.

Application of Lone Star Transmission, LLC to Amend Its Certificate of Convenience and Necessity for the Proposed Reata Station to Roadrunner Crossing Wind 345 kV Transmission Line in Eastland County

16. Schematic or Diagram:

For a standard application, provide a schematic or diagram of the applicant's transmission system in the proximate area of the project. Show the location and voltage of existing transmission lines and substations, and the location of the construction. Locate any taps, ties, meter points, or other facilities involving other utilities on the system schematic.

A schematic of Lone Star's transmission system in the proximate area of the Project is included as Attachment 4 to this Application.

17. Routing Study:

Provide a brief summary of the routing study that includes a description of the process of selecting the study area, identifying routing constraints, selecting potential line segments, and the selection of the routes. Provide a copy of the complete routing study conducted by the utility or consultant. State which route the applicant believes best addresses the requirements of PURA and P.U.C. Substantive Rules.

Lone Star retained Burns & McDonnell to prepare the EA for the proposed Project. A copy of the EA is included as Attachment 1 to this Application. The EA presents the analysis that was conducted by Burns & McDonnell, as well as the land use and environmental data for the Consensus Route that was considered for this Project. The following summary is based on information provided in Section 2 of the EA.

The objective of the EA was to evaluate the proposed 345 kV transmission line location for compliance with PURA § 37.056(c)(4)(A)-(D), 16 TAC § 25.101(b)(3)(B), and 16 TAC § 22.52(a)(4), including the Commission's policy of prudent avoidance. Burns & McDonnell used a comprehensive transmission line evaluation methodology to evaluate the proposed route of the transmission line location. Methods used were governed by factors set forth in PURA § 37.056(c)(4) and 16 TAC § 25.101(b)(3).

Process of Selecting the Study Area: The first step in the assessment of the Project was to delineate a study area. The study area needed to encompass the endpoints for the proposed Project (the proposed Reata Station and the proposed Roadrunner Crossing Wind Collector Station) and include an area large enough to adequately evaluate the proposed transmission line Project in support of Lone Star's Application. The purpose of delineating a Study Area for the Project was to establish boundaries and limits in which to identify environmental and land use constraints during the information gathering process to properly identify and map various items included within the Commission's CCN application. The Study Area was delineated at approximately one-half mile from the Consensus Route's centerline and measures approximately one (1) mile east to west by approximately 3.5 miles north to south, encompassing a total area of approximately 3.5 square miles primarily in the northwestern portion of Eastland County. The westernmost extent of the Study Area is located in Callahan County.

Identification of Routing Constraints: Data used in the evaluation of the Project were drawn from a variety of sources, including published literature, information from local, state and federal agencies, recent aerial photography, and ground reconnaissance of the Study Area. In identifying constraints, Burns & McDonnell considered numerous land use, ecological, and cultural resources within the Study Area.

To quantify potential impacts to sensitive environmental and land use features, a constraints mapping process was used in evaluating the Project. The geographic locations of environmentally sensitive and other restrictive areas within the Study Area were identified and considered during the evaluation process. These constraints were mapped onto an aerial base map (Figure 2-2 of the EA) created using 2019 NAIP imagery and 2018 ESRI Maxar WorldView-3 Satellite imagery. Section 2 of the EA describes Burns & McDonnell's process for identifying routing constraints in more detail.

Application of Lone Star Transmission, LLC to Amend Its Certificate of Convenience and Necessity for the Proposed Reata Station to Roadrunner Crossing Wind 345 kV Transmission Line in Eastland County

Identification of the Consensus Route: Lone Star selected the Consensus Route based on evaluation of the potential impacts along with consideration of the direct path between the interconnection points, being parallel to CR 126 the length of transmission line, number of structures, number of land parcels crossed, and cost. In addition, Lone Star contacted the landowners in the Study Area who owned a parcel that would be crossed by the Consensus Route to obtain their input in regards to the Consensus Route and support of the filed Consensus Route. The landowners crossed by the Consensus Route each have provided their written consent to the Consensus Route that is being presented in the Application (Attachment 2 to this Application). Following its evaluation, Lone Star determined that the Consensus Route complies with the requirements of PURA and the Commission's Substantive Rules.

18. Public Meeting or Public Open House:

Provide the date and location for each public meeting or public open house that was held in accordance with 16 TAC § 22.52. Provide a summary of each public meeting or public open house including the approximate number of attendants, and a copy of any survey provided to attendants and a summary of the responses received. For each public meeting or public open house provide a description of the method of notice, a copy of any notices, and the number of notices that were mailed and/or published.

Not applicable. Pursuant to 16 TAC § 22.52(a)(4), because fewer than 25 persons are entitled to receive direct notice of the Application, no public meeting was held prior to filing of this Application. Lone Star has discussed the proposed Consensus Route with the two directly affected landowners and answered questions regarding the location, transmission structure type, and ROW width. Both landowners consented to the location of the Consensus Route on their property.

In addition, consistent with 16 TAC § 22.52(a)(4), Lone Star sent a letter to the Department of Defense (DoD) Siting Clearinghouse on April 24, 2020 notifying it of the Project and that Lone Star was preparing an EA and CCN application.

19. Routing Maps:

Base maps should be a full scale (one inch = not more than one mile) highway map of the county or counties involved, or other maps of comparable scale denoting sufficient cultural and natural features to permit location of all routes in the field. Provide a map (or maps) showing the study area, routing constraints, and all routes or line segments that were considered prior to the selection of the routes. Identify the routes and any existing facilities to be interconnected or coordinated with the project. Identify any taps, ties, meter points, or other facilities involving other utilities on the routing map. Show all existing transmission facilities located in the study area. Include the locations of radio transmitters and other electronic installations, airstrips, irrigated pasture or cropland, parks and recreational areas, historical and archeological sites (subject to the instructions in Question 27), and any environmentally sensitive areas (subject to the instructions in Question 29).

Routing maps are provided in the EA (Attachment 1 to this Application). Figure 2-2 in the EA is an aerial-photograph-based map with a scale of 1 inch = 1,000 feet that shows the Study Area, the Consensus Route, existing transmission lines, and other environmental and land use features.

Provide aerial photographs of the study area displaying the date that the photographs were taken or maps that show (1) the location of each route with each route segment identified, (2) the locations of all major public roads including, as a minimum, all federal and state roadways, (3) the locations of all known habitable structures or groups of habitable structures (see Question 19 below) on properties directly affected by any route, and (4) the boundaries (approximate or estimated according to best available information if required) of all properties directly affected by any route.

An aerial photograph-based property ownership map with a scale of 1 inch = 1,600 feet is included in this Application as Attachment 5. It shows the approximate boundaries of all properties that are directly

Application of Lone Star Transmission, LLC to Amend Its Certificate of Convenience and Necessity for the Proposed Reata Station to Roadrunner Crossing Wind 345 kV Transmission Line in Eastland County

affected by the proposed Consensus Route, according to the best information available from Eastland County tax appraisal district records. No habitable structure or group of habitable structures are located within 500 feet of the Consensus Route centerline.

For each route, cross-reference each habitable structure (or group of habitable structures) and directly affected property identified on the maps or photographs with a list of corresponding landowner names and addresses and indicate which route segment affects each structure/group or property.

No habitable structure or group of habitable structures are located within 500 feet of the Consensus Route. Landowner names, property identification, and map locations are included in a cross-reference table provided as Attachment 6 to this Application.

20. Permits:

List any and all permits and/or approvals required by other governmental agencies for the construction of the proposed project. Indicate whether each permit has been obtained.

Lone Star will coordinate with appropriate local, state, and federal agencies with jurisdiction regarding the construction of the transmission facilities associated with the Project. Lone Star and/or Burns & McDonnell have initiated contact with and provided information about the Project to various agencies. Input from these agencies has been incorporated in the Application; however, requests for permits and/or approvals will not be submitted to the appropriate agencies until the alignment of the Consensus Route has been approved by the Commission. The following potential permits, approvals, requirements, easements, or clearances could be required, but have not been obtained at this time.

- The Eastland County Judge and Floodplain Administrator provided a preliminary opinion that the proposed Project is not located in a flood hazard zone and will not interfere with flood plain management in Eastland County. Lone Star will continue to coordinate with the County and will obtain floodplain development permits and road crossing permits if any are needed.
- Cultural resource clearance will be obtained from the Texas Historical Commission (THC) for the proposed Project ROW as necessary.
- A Storm Water Pollution Prevention Plan (SWPPP) may be required by the Texas Commission on Environmental Quality (TCEQ). Lone Star or its contractor will submit a Notice of Intent to the TCEQ at least 48 hours prior to the beginning of construction, and will maintain the SWPPP on site at the initiation of clearing and construction activities.
- After alignments and structure locations/heights are adjusted and set, Lone Star will make a final determination of the need for Federal Aviation Administration (FAA) notification, based on structure locations and structure designs. In some areas, if necessary, Lone Star could use lower-than-typical structure heights or add marking and/or lighting to certain structures.
- Permits or other requirements associated with possible impacts to endangered/threatened species will be coordinated with the United States Fish and Wildlife Service (USFWS) as necessary.
- Coordination with Texas Parks & Wildlife Department (TPWD) may be necessary to determine the need for any surveys, and to avoid or minimize any potential adverse impacts to sensitive habitats, threatened or endangered species, and other fish and wildlife resources along the approved route.
- Permits or other requirements associated with possible impacts to waters of the U.S. under the jurisdiction of the U.S. Army Corps of Engineers (USACE) will be coordinated with the USACE as necessary.

Further discussion of permits that may be required for the Project is included in Section 1.6 of the EA.

21. Habitable structures:

For each route list all single-family and multi-family dwellings and related structures, mobile homes, apartment buildings, commercial structures, industrial structures, business structures, churches, hospitals, nursing homes, schools, or other structures normally inhabited by humans or intended to be inhabited by humans on a daily or regular basis within 300 feet of the centerline if the proposed project will be constructed for operation at 230kV or less, or within 500 feet of the centerline if the proposed project will be constructed for operation at greater than 230kV. Provide a general description of each habitable structure and its distance from the centerline of the route. In cities, towns or rural subdivisions, houses can be identified in groups. Provide the number of habitable structures in each group and list the distance from the centerline of the route to the closest and the farthest habitable structure in the group. Locate all listed habitable structures or groups of structures on the routing map.

No habitable structure is located within 500 feet of the Consensus Route's centerline.

22. Electronic Installations:

For each route, list all commercial AM radio transmitters located within 10,000 feet of the center line of the route, and all FM radio transmitters, microwave relay stations, or other similar electronic installations located within 2,000 of the center line of the route. Provide a general description of each installation and its distance from the center line of the route. Locate all listed installations on a routing map.

As indicated in Table 6-1 of the EA, no AM radio transmitter was determined to be located within 10,000 feet of the Consensus Route. No FM radio transmitter, microwave tower, or other electronic installation was determined to be located within 2,000 feet of the centerline of the Consensus Route.

23. Airstrips:

For each route, list all known private airstrips within 10,000 feet of the center line of the project. List all airports registered with the Federal Aviation Administration (FAA) with at least one runway more than 3,200 feet in length that are located within 20,000 feet of the center line of any route. For each such airport, indicate whether any transmission structures will exceed a 100:1 horizontal slope (one foot in height for each 100 feet in distance) from the closest point of the closest runway. List all listed airports registered with the FAA having no runway more than 3,200 feet in length that are located within 10,000 feet of the center line of any route. For each such airport, indicate whether any transmission structures will exceed a 50:1 horizontal slope from the closest point of the closest runway. List all heliports located within 5,000 feet of the center line of any route. For each such heliport, indicate whether any transmission structures will exceed a 25:1 horizontal slope from the closest point of the closest landing and takeoff area of the heliport. Provide a general description of each listed private airstrip, registered airport, and heliport; and state the distance of each from the center line of each route. Locate and identify all listed airstrips, airports, and heliports on a routing map.

As indicated in Table 6-1 of the EA, there are:

- No known private airstrips located within 10,000 feet of the centerline of the Consensus Route;
- No airports registered with the FAA with at least one runway more than 3,200 feet in length located within 20,000 feet of the centerline of the Consensus Route;
- No airports registered with the FAA having no runway more than 3,200 feet in length located within 10,000 feet of the centerline of the Consensus Route; and
- No heliports located within 5,000 feet of the centerline of the Consensus Route.

Application of Lone Star Transmission, LLC to Amend Its Certificate of Convenience and Necessity for the Proposed Reata Station to Roadrunner Crossing Wind 345 kV Transmission Line in Eastland County

24. Irrigation Systems:

For each route identify any pasture or cropland irrigated by traveling irrigation systems (rolling or pivot type) that will be traversed by the route. Provide a description of the irrigated land and state how it will be affected by each route (number and type of structures, etc.). Locate any such irrigated pasture or cropland on a routing map.

No pasture or cropland irrigated by traveling irrigation systems (rolling or pivot type) will be traversed by the Consensus Route.

25. Notice:

Notice is to be provided in accordance with 16 TAC § 22.52.

A. Provide a copy of the written direct notice to owners of directly affected land. Attach a list of the names and addresses of the owners of directly affected land receiving notice.

Sample copies of the written direct notice and enclosures that were mailed to the owners of directly affected land are provided in Attachments 7A through 7F. The list of the names and addresses of the two owners of directly affected land receiving notice is provided in Attachment 7G.

B. Provide a copy of the written notice to utilities that are located within five miles of the routes.

A sample copy of the written notice to utilities that are located within five miles of the proposed Project is provided in Attachment 8. The list of the contact names and addresses of these utilities also is provided in Attachment 8.

C. Provide a copy of the written notice to county and municipal authorities, and the Department of Defense Siting Clearinghouse. Notice to the DoD Siting Clearinghouse should be provided at the email address found at <http://www.acq.osd.mil/dodsc/>.

A sample copy of the written notice sent to Eastland County officials and the DoD Siting Clearinghouse is included in Attachment 9. Since the proposed route will not pass through and is not within five miles of any municipality, no municipalities were notified.

In addition to the notices above, 16 TAC § 22.52(a)(2) requires Lone Star to provide notice of this Application to the Office of Public Utility Counsel. A sample copy of this notice is included in the Application as Attachment 9.

The list of names of public officials to which notice is being provided also is included in Attachment 9.

D. Provide a copy of the notice that is to be published in newspapers of general circulation in the counties in which the facilities are to be constructed. Attach a list of the newspapers that will publish the notice for this application. After the notice is published, provide the publisher's affidavits and tear sheets.

A sample copy of the notice to be published in the newspaper of general circulation in the county in which the proposed facilities are to be constructed is provided in Attachment 10. The notice for this Application will be published in the Eastland County Today Cisco Press in Cisco, Texas, which is a newspaper of general circulation in Eastland County and is listed in Attachment 10.

Application of Lone Star Transmission, LLC to Amend Its Certificate of Convenience and Necessity for the Proposed Reata Station to Roadrunner Crossing Wind 345 kV Transmission Line in Eastland County

For a CREZ application, in addition to the requirements of P.U.C. Proc. R. 22.52, the applicant shall, not less than twenty-one (21) days before the filing of the application, submit to the Commission staff a "generic" copy of each type of alternative published and written notice for review. Staff's comments, if any, regarding the alternative notices will be provided to the applicant not later than seven days after receipt by Staff of the alternative notices. Applicant may take into consideration any comments made by Commission staff before the notices are published or sent by mail.

Not applicable. This is not a CREZ application.

26. Parks and Recreation Areas:

For each route, list all parks and recreational areas owned by a governmental body or an organized group, club, or church and located within 1,000 feet of the center line of the route. Provide a general description of each area and its distance from the center line. Identify the owner of the park or recreational area (public agency, church, club, etc.). List the sources used to identify the parks and recreational areas. Locate the listed sites on a routing map.

Burns & McDonnell performed a review of federal and state databases, county, and local maps to identify parks and/or recreational areas within the Study Area. Reconnaissance surveys were also conducted to identify any additional park or recreational area located within the Study Area. No park or recreational area is crossed by the Consensus Route centerline. Additionally, no park or recreation area is located within 1,000 feet of the Consensus Route's centerline.

27. Historical and Archeological Sites:

For each route, list all historical and archeological sites known to be within 1,000 feet of the center line of the route. Include a description of each site and its distance from the center line. List the sources (national, state or local commission or societies) used to identify the sites. Locate all historical sites on a routing map. For the protection of the sites, archeological sites need not be shown on maps.

To identify the historical and archeological sites in the Study Area, Burns & McDonnell researched the available records and literature at the Texas Archeological Research Laboratory, J.J. Pickle Research Campus, at the University of Texas at Austin. In addition, the Texas Historical Commission's Archeological Sites Atlas files were used to identify listed and eligible National Register of Historical Places (NRHP) properties and sites, NRHP districts, cemeteries, Official Texas Historical Markers, State Archeological Landmarks, and any other potential cultural resources such as National Historic Landmarks, National Monuments, National Memorials, National Historic Sites, and National Historical Parks, to ensure the completeness of the study. To identify areas with a high probability for the occurrence of cultural resources, Burns & McDonnell used the Bernie Lake 7.5-minute topographic map, the Texas Department of Transportation's (TxDOT) Potential Archeological Liability Map (PALM), and aerial photography.

Table 6-1 of the EA indicates that no known cultural resource site is crossed by the Consensus Route centerline. One previously recorded cultural resource site is located within 1,000 feet of the Consensus Route centerline. This site, surveyed in 2012, includes the remnants of a historic-age farmstead. This site was determined ineligible for NRHP inclusion.

No NRHP-listed or determined-eligible site is crossed by or within 1,000 feet of the Consensus Route centerline.

Application of Lone Star Transmission, LLC to Amend Its Certificate of Convenience and Necessity for the Proposed Reata Station to Roadrunner Crossing Wind 345 kV Transmission Line in Eastland County

28. Coastal Management Program:

For each route, indicate whether the route is located, either in whole or in part, within the coastal management program boundary as defined in 31 TAC §503.1. If any route is, either in whole or in part, within the coastal management program boundary, indicate whether any part of the route is seaward of the Coastal Facilities Designation Line as defined in 31 TAC §19.2(a)(21). Using the designations in 31 TAC §501.3(b), identify the type(s) of Coastal Natural Resource Area(s) impacted by any part of the route and/or facilities.

No part of the Consensus Route occurs within the coastal management program boundary, as defined in 31 TAC § 503.1.

29. Environmental Impact:

Provide copies of any and all environmental impact studies and/or assessments of the project. If no formal study was conducted for this project, explain how the routing and construction of this project will impact the environment. List the sources used to identify the existence or absence of sensitive environmental areas. Locate any environmentally sensitive areas on a routing map. In some instances, the location of the environmentally sensitive areas or the location of protected or endangered species should not be included on maps to ensure preservation of the areas or species. Within seven days after filing the application for the project, provide a copy of each environmental impact study and/or assessment to the Texas Parks and Wildlife Department (TPWD) for its review at the address below. Include with this application a copy of the letter of transmittal with which the studies/assessments were or will be sent to the TPWD.

Wildlife Habitat Assessment Program
Wildlife Division
Texas Parks and Wildlife Department 4200
Smith School Road
Austin, Texas 78744

The EA that was conducted by Burns & McDonnell is included with this Application at Attachment 1. Data used by Burns & McDonnell in the evaluation of the proposed Consensus Route were drawn from a variety of sources, including, published literature (e.g., documents, reports, maps, aerial photography), and information from local, state, and federal agencies. An extensive list of resources is provided in Section 8 of the EA. Ground reconnaissance of the Study Area and computer-based evaluation of digital aerial imagery were used for the evaluation of the proposed Consensus Route. Environmentally sensitive areas are shown on Figure 2-2 of the EA.

The applicant shall file an affidavit confirming that the letter of transmittal and studies/assessments were sent to TPWD.

A copy of the letter of transmittal providing a copy of the Application, which includes the EA for this Project, to TPWD is included in this Application as Attachment 11. An affidavit verifying that the letter of transmission and EA were sent to TPWD will be filed with the Commission.

30. Affidavit

Attach a sworn affidavit from a qualified individual authorized by the applicant to verify and affirm that, to the best of their knowledge, all information provided, statements made, and matters set forth in this application and attachments are true and correct.

The sworn affidavit of Stacie Bennett is included with this Application as Attachment 12.

**Lone Star Transmission, LLC
CCN Application – List of Attachments**

Attachment Number	Attachment Description
Attachment 1	Environmental Assessment of the Proposed Reata Station to Roadrunner Crossing Wind 345 kV Transmission Line in Eastland County, prepared by Burns & McDonnell Engineering Company, Inc. (EA)
Attachment 2	Consensus Route Agreements
Attachment 3	Interconnection Agreement between Lone Star Transmission, LLC and Roadrunner Crossing Wind Farm, LLC, dated April 17, 2020
Attachment 4	Schematic of the Lone Star Transmission, LLC System in the Proximate Area of the Proposed Project
Attachment 5	Aerial Photograph-Based Property Ownership Map
Attachment 6	Table Providing Landowner Names, Property Identification, and Map Locations
Attachment 7	Landowner Notice Materials: Attachment 7A Sample Notice Letter to Landowners Attachment 7B Map of Consensus Route Attachment 7C Consensus Route Description Attachment 7D Landowner Brochure Attachment 7E Comment/Protest Form Attachment 7F Intervenor Form Attachment 7G Landowner List
Attachment 8	List of Utilities and Sample Notice Letter to Utilities*
Attachment 9	List of Eastland County Officials, the Department of Defense Siting Clearinghouse, and the Office of Public Utility Counsel Contacts and Sample Notice Letter*
Attachment 10	Sample Newspaper Notice and List of Newspaper of General Circulation
Attachment 11	Letter of Transmittal to the Texas Parks & Wildlife Department
Attachment 12	Sworn Affidavit of Stacie Bennett

* Excluding maps and route descriptions provided in Attachment 7.

Environmental Assessment



Proposed Reata Station to Roadrunner Crossing Wind 345 kV Transmission Line Project

Docket No. 50910

June 2020

Environmental Assessment

prepared for

Lone Star Transmission, LLC

**Proposed Reata Station to Roadrunner Crossing Wind
345 kV Transmission Line Project in
Eastland County, Texas**

Docket No. 50910

June 2020

prepared by

**Burns & McDonnell Engineering Company, Inc.
Austin, Texas**

COPYRIGHT © 2020 BURNS & McDONNELL ENGINEERING COMPANY, INC.

TABLE OF CONTENTS

	<u>Page No.</u>
1.0 DESCRIPTION OF THE PROPOSED PROJECT	1-1
1.1 Scope of Project	1-1
1.2 Purpose and Need	1-1
1.3 Description of Proposed Design and Construction	1-3
1.3.1 Loading, Weather Data, and Design Criteria	1-3
1.3.2 Structural and Geotechnical	1-3
1.3.3 Right-of-Way Requirements	1-6
1.4 Construction Considerations	1-6
1.4.1 Clearing	1-6
1.4.2 Construction	1-7
1.4.3 Cleanup	1-8
1.5 Maintenance Considerations	1-9
1.6 Agency Actions	1-9
1.6.1 Public Utility Commission of Texas	1-10
1.6.2 Federal Aviation Administration	1-10
1.6.3 U.S. Army Corps of Engineers	1-10
1.6.4 U.S. Fish and Wildlife Service	1-11
1.6.5 Federal Emergency Management Agency	1-11
1.6.6 U.S. Department of Defense Siting Clearinghouse	1-12
1.6.7 Texas Parks and Wildlife Department	1-12
1.6.8 Texas Commission on Environmental Quality	1-12
1.6.9 Texas Department of Transportation	1-13
1.6.10 Texas Historical Commission	1-13
1.6.11 Texas General Land Office	1-13
1.6.12 Eastland County	1-13
 2.0 ROUTE EVALUATION METHODOLOGY	 2-1
2.1 Objective of Study	2-1
2.2 Data Collection	2-1
2.3 Evaluation of the Route	2-1
2.3.1 Study Area Delineation	2-1
2.3.2 Constraints Mapping	2-2
2.3.3 Evaluation Factors	2-2
 3.0 EXISTING ENVIRONMENT	 3-1
3.1 Physiography	3-1
3.2 Geology	3-1
3.3 Soils	3-3
3.3.1 Soil Associations	3-3
3.3.2 Prime Farmland Soils	3-3
3.4 Mineral and Energy Resources	3-4

3.5	Water Resources	3-5
3.5.1	Surface Water.....	3-5
3.5.2	Floodplains.....	3-5
3.5.3	Groundwater	3-5
3.6	Vegetation.....	3-6
3.6.1	Regional Vegetation.....	3-6
3.6.2	Vegetation Community Types in the Study Area.....	3-6
3.6.3	Waters of the U.S., Including Wetlands	3-9
3.7	Fish and Wildlife.....	3-10
3.7.1	Fish and Wildlife Habitats and Species	3-10
3.7.2	Fish.....	3-10
3.7.3	Amphibians and Reptiles	3-12
3.7.4	Birds.....	3-13
3.7.5	Mammals.....	3-15
3.8	Recreationally and Commercially Important Species.....	3-16
3.9	Endangered and Threatened Species	3-17
3.9.1	Endangered and Threatened Plant Species	3-17
3.9.2	Federally Listed Fish and Wildlife Species	3-17
3.9.3	Critical Habitat.....	3-23
3.9.4	State-Listed Fish and Wildlife Species	3-23
3.10	Human Resources	3-24
3.10.1	Community Values and Community Resources	3-24
3.10.2	Land Use	3-25
3.10.3	Recreation	3-26
3.10.4	Agriculture	3-26
3.10.5	Transportation and Aviation	3-27
3.10.6	Communication Towers.....	3-27
3.10.7	Utilities.....	3-27
3.10.8	Aesthetic Values	3-27
3.11	Cultural Resources	3-29
3.11.1	Paleoindian.....	3-29
3.11.2	Archaic.....	3-31
3.11.3	Ceramic	3-31
3.11.4	Protohistoric.....	3-32
3.11.5	Historic.....	3-32
3.11.6	Literature and Records Review.....	3-33
4.0	ENVIRONMENTAL IMPACTS OF THE PROJECT	4-1
4.1	Impact on Natural Resources	4-1
4.1.1	Impact on Physiography and Geology	4-1
4.1.2	Impact on Soils	4-1
4.1.3	Impact on Water Resources	4-2
4.1.4	Impact on the Ecosystem	4-3
4.2	Impact on Human Resources	4-8
4.2.1	Impact on Community Values	4-8
4.2.2	Impact on Land Use.....	4-8

4.2.3	Impact on Recreation	4-10
4.2.4	Impact on Agriculture	4-10
4.2.5	Impact on Transportation and Aviation	4-10
4.2.6	Impact on Communication Towers.....	4-11
4.2.7	Impact on Utilities.....	4-11
4.2.8	Impact on Aesthetics.....	4-11
4.3	Impact on Cultural Resources	4-12
4.3.1	Direct Impacts	4-12
4.3.2	Indirect Impacts	4-13
4.3.3	Mitigation.....	4-13
4.3.4	Summary of Impact on Cultural Resources	4-13
5.0	PUBLIC INVOLVEMENT ACTIVITIES.....	5-1
5.1	Correspondence with Agencies and Officials.....	5-1
5.2	Public Open-House Meetings	5-4
6.0	PROJECT ASSESSMENT	6-1
7.0	LIST OF PREPARERS	7-1
8.0	REFERENCES	8-1
APPENDIX A - AGENCY CORRESPONDENCE		

LIST OF TABLES

	<u>Page No.</u>
Table 2-1: Environmental Criteria for Reata Station to Roadrunner Crossing Wind.....	2-5
Table 3-1: Representative List of Reptile and Amphibian Species of Potential Occurrence in the Study Area.....	3-12
Table 3-2: Representative List of Avian Species of Potential Occurrence in the Study Area	3-13
Table 3-3: Representative List of Mammalian Species of Potential Occurrence in the Study Area.....	3-15
Table 3-4: Federally Listed Fish and Wildlife Species for Eastland and Callahan Counties.....	3-18
Table 3-5: State-Listed Fish and Wildlife Species for Eastland and Callahan Counties.....	3-23
Table 6-1: Environmental Data for Consensus Route Assessment Reata Station to Roadrunner Crossing Wind 345 kV Transmission Line Project.....	6-2

LIST OF FIGURES

	<u>Page No.</u>
Figure 1-1: Project Location	1-2
Figure 1-2: Typical Monopole Tangent Structure.....	1-4
Figure 1-3: Typical Monopole Deadend Structure	1-5
Figure 2-1: Study Area Location.....	2-3
Figure 2-2: Environmental and Land Use Constraints Within the Study Area.....(Map Pocket)	
Figure 3-1: Location of Eastland County in Relation to the Physiographic Provinces of Texas	3-2
Figure 3-2: Location of Eastland County in Relation to the Vegetational Areas of Texas	3-7
Figure 3-3: Location of Eastland County in Relation to the Biotic Provinces of Texas.....	3-11
Figure 3-4: Location of Eastland County in Relation to the Central U.S. Whooping Crane Flyway	3-20
Figure 3-5: Location of Eastland County in Relation to the Cultural Resources Planning Regions of Texas.....	3-30

LIST OF ACRONYMS AND ABBREVIATIONS

<u>Abbreviation</u>	<u>Term/Phrase/Name</u>
ACSR	Aluminum Conductor Steel Reinforced
APLIC	Avian Power Line Interaction Committee
AWBP	Aransas-Wood Buffalo Population
BEG	Bureau of Economic Geology
BGEPA	Bald and Golden Eagle Protection Act
BMP	best management practice
Burns & McDonnell	Burns & McDonnell Engineering Company, Inc.
CCN	Certificate of Convenience and Necessity
CFR	Code of Federal Regulations
CR	County Road
CREZ	Competitive Renewable Energy Zone
CWA	Clean Water Act
CWCTP	Cooperative Whooping Crane Tracking Project
EA	Environmental Assessment
EMST	Ecological Mapping Systems of Texas
EPA	U.S. Environmental Protection Agency
ESA	Endangered Species Act
FAA	Federal Aviation Administration
FAR	Federal Aviation Regulations
FCC	Federal Communications Commission
FEMA	Federal Emergency Management Agency
FL	floor level
FM	Farm-to-Market Road
ft.	foot/feet
FVZ	foreground visual zone
GIS	geographic information system

<u>Abbreviation</u>	<u>Term/Phrase/Name</u>
GLO	General Land Office
HPA	high probability area
IPaC	Information, Planning, and Conservation
ISD	Independent School District
kV	kilovolt
MBTA	Migratory Bird Treaty Act
ME	Miscellaneous Easement
MOA	Military Operations Area
MW	megawatt
msl	mean sea level
NAIP	National Agriculture Imagery Program
NDD	TPWD's Natural Diversity Database
NEPA	National Environmental Policy Act
NERC	North American Electric Reliability Corporation
NESC	National Electrical Safety Code
NOI	Notice of Intent
NOT	Notice of Termination
NPS	National Park Service
NRCS	Natural Resources Conservation Service
NRHP	National Register of Historic Places
NWI	National Wetlands Inventory
NWP	Nationwide Permit
NWR	National Wildlife Refuge
OTHM	Official Texas Historical Marker
PALM	Potential Archeological Liability Map
Project	Proposed Reata Station to Roadrunner Crossing Wind 345 kV Transmission Line in Eastland County, Texas
PSF	Permanent School Fund

<u>Abbreviation</u>	<u>Term/Phrase/Name</u>
PUC	Public Utility Commission of Texas
PURA	Public Utility Regulatory Act
ROW	right-of-way
RRC	Railroad Commission of Texas
RTHL	Recorded Texas Historic Landmark
SAL	State Antiquities Landmark
SCS	Soil Conservation Service
SH	State Highway
SWPPP	Storm Water Pollution Prevention Plan
TAC	Texas Administrative Code
TARC	Texas Association of Regional Councils
TARL	Texas Archeological Research Laboratory
TASA	Texas Archeological Sites Atlas
TCEQ	Texas Commission on Environmental Quality
TEA	Texas Education Agency
THC	Texas Historical Commission
TORP	Texas Outdoor Recreation Plan
TPDES	Texas Pollution Discharge Elimination System
TPWD	Texas Parks and Wildlife Department
TSHA	Texas State Historical Association
TWDB	Texas Water Development Board
TxDOT	Texas Department of Transportation
U.S.	United States
USACE	U.S. Army Corps of Engineers
USDA	U.S. Department of Agriculture
USFWS	U.S. Fish and Wildlife Service
USGS	U.S. Geological Survey

Abbreviation

Term/Phrase/Name

WCTCOG

West Central Texas Council of Governments

1.0 DESCRIPTION OF THE PROPOSED PROJECT

1.1 Scope of Project

Lone Star Transmission, LLC (Lone Star) is proposing to design and construct new electric transmission facilities in Eastland County, Texas. The proposed project (Project) is a new 345 kilovolt (kV) single-circuit transmission line that will be constructed between Lone Star's proposed Reata Station, which will be located north of Lone Star's existing West Shackelford to Sam Switch 345 kV transmission line, on the east side of County Road (CR) 126 (approximately 1.1 mile north of Farm-to-Market road (FM) 2945), and the proposed Roadrunner Crossing Wind Collector Substation, located southeast of the CR 125 and CR 126 intersection. Lone Star is proposing one route, the Consensus Route, for the Project because the two landowners directly affected by the Consensus Route have provided their written agreement to the Consensus Route. The new line will be approximately 2.3 miles long with an approximate 100- to 150-foot-wide right-of-way (ROW). Figure 1-1 shows the Project location. The Study Area is described in Section 2.3.1 and shown on Figure 2-1.

Lone Star contracted with Burns & McDonnell Engineering Company, Inc. (Burns & McDonnell) to prepare this Environmental Assessment (EA) to support its application for a Certificate of Convenience and Necessity (CCN) to be submitted to the Public Utility Commission of Texas (PUC) for the Project. This document has been prepared to provide information and address requirements of § 37.056(c)(4)(A-D) of the Public Utility Regulatory Act (PURA), the PUC's CCN application form, the PUC's rules in 16 Texas Administrative Code (TAC) § 25.101, and the PUC's policy of "prudent avoidance." This document is intended to provide information and address issues concerning the natural, human, and cultural environment within the Study Area. This document may also be used in support of any additional local, State, or Federal permitting activities that may be required for Lone Star's proposed Project.

1.2 Purpose and Need

This proposed Project is necessary to directly interconnect a new transmission service customer, Roadrunner Crossing Wind Farm, LLC (Roadrunner Crossing Wind), into Lone Star's proposed Reata Station adjacent to Lone Star's existing West Shackelford to Sam Switch 345 kV transmission line. Roadrunner Crossing Wind has requested that Lone Star interconnect its proposed 200.2-megawatt (MW) wind generation development. PUC Electric Substantive Rule 25.191(d) requires a transmission service provider to interconnect a generator once the other conditions are completed for transmission service as defined in 16 TAC § 25.195(c).

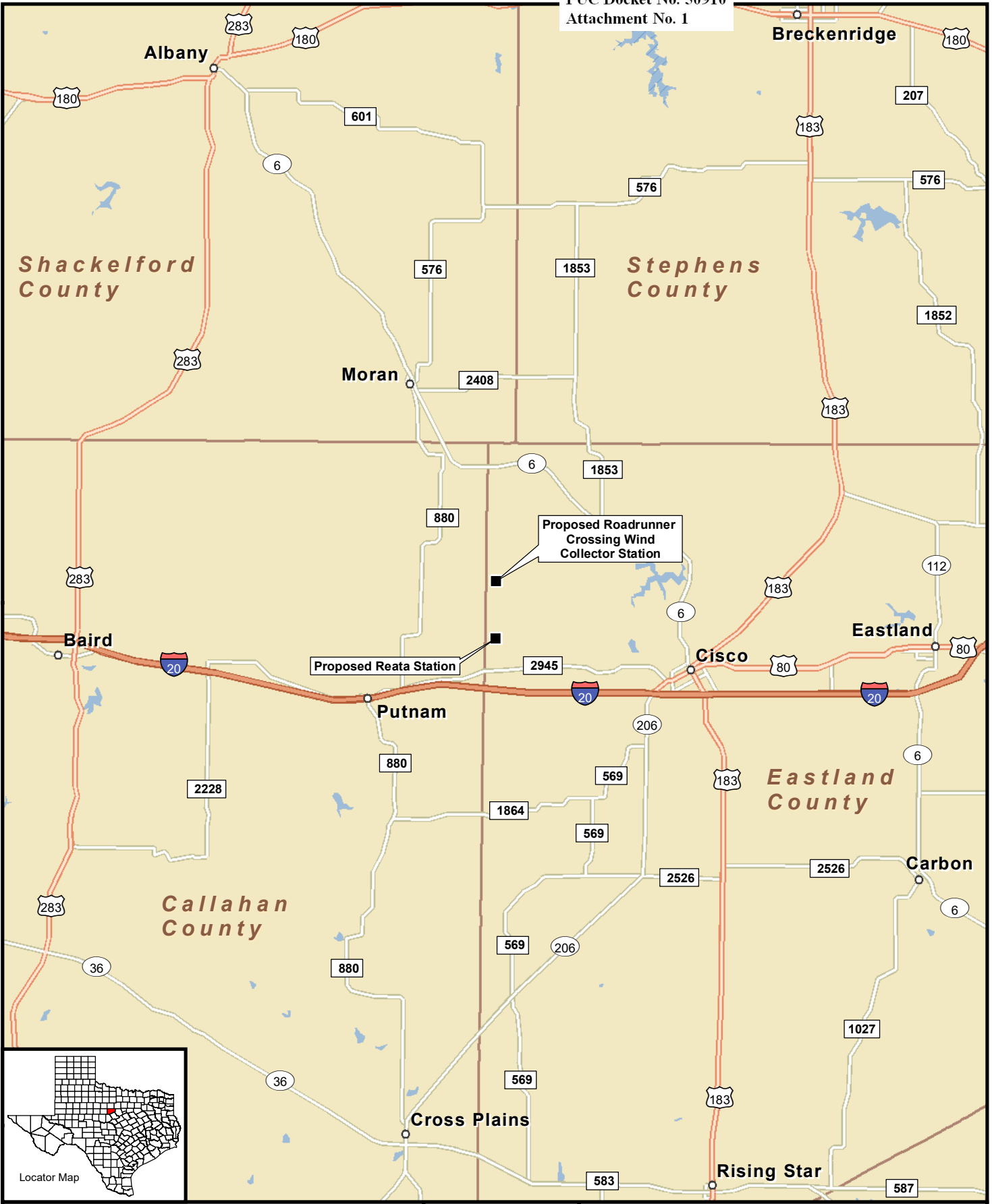

Path: \\dalsv\data\Projects\ESP\ONE STAR TRANSMISSION\Roadrunner 345kV\Geospatial\DataFiles\ArcDocs\RX2RS_Figure_1_1_ProjectLocation.mxd gacox 6/16/2020

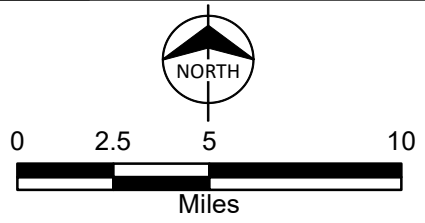
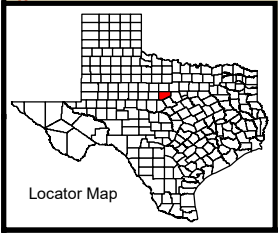

Figure 1-1
Project Location
Reata Station to Roadrunner Crossing Wind
345 kV Transmission Line
Lone Star Transmission
Eastland County, Texas

1.3 Description of Proposed Design and Construction

The following information presents the proposed design and construction of facilities for the 345 kV transmission line.

1.3.1 Loading, Weather Data, and Design Criteria

Lone Star's proposed 345 kV single-circuit transmission line is located in the American National Standards Institute (ANSI) National Electrical Safety Code (NESC) Heavy Loading Zone and will be designed to meet or exceed NESC 2017 loading criteria (ANSI C2-2017). Depending on the type of structure used, various combinations of vertical, transverse (wind), and longitudinal loadings (with and without ice) will be analyzed as to the effects on the structures. The new 345 kV transmission line will be capable of supporting bundled 795 kcmil aluminum conductor steel reinforced (ACSR) "Drake," two conductors per phase, one optical ground wire (OPGW) and an additional 7#7 alumoweld shield wire.

All structure components, conductors, and overhead ground wires will be designed using the appropriate overload capacity factors, strength reduction factors, and tension limits as given in the NESC and the manufacturer's recommended strength ratings for hardware. In addition to the NESC requirements, additional loading cases that exceed the NESC will also be used per Lone Star standards. These load cases include an unbalanced loading case as well as a case to limit structure deflection under normal, everyday loads. The NESC Heavy-Loading Zone design criteria, extreme wind, and concurrent wind and ice-loading conditions will be used to determine tension sags for all wires.

1.3.2 Structural and Geotechnical

The typical dead-end and tangent structures for this Project will be concrete monopole structures, with guying on dead-end structures as necessary. The typical structure heights will be approximately 90 to 120 feet (ft.), but will vary depending on the terrain and clearance requirements.

All structures will be designed to support conductors and shield wires as specified above. The configuration of the conductor and shield wires will provide adequate lightning protection and the appropriate clearances for operation of a 345 kV single-circuit transmission line. The geometry of a typical monopole single-circuit tangent structure and a monopole single-circuit dead-end structure are shown on Figure 1-2 and Figure 1-3, respectively. Geotechnical considerations will include soil borings and in-situ soils testing to provide the parameters for foundation design and embedment depths required for new structures.

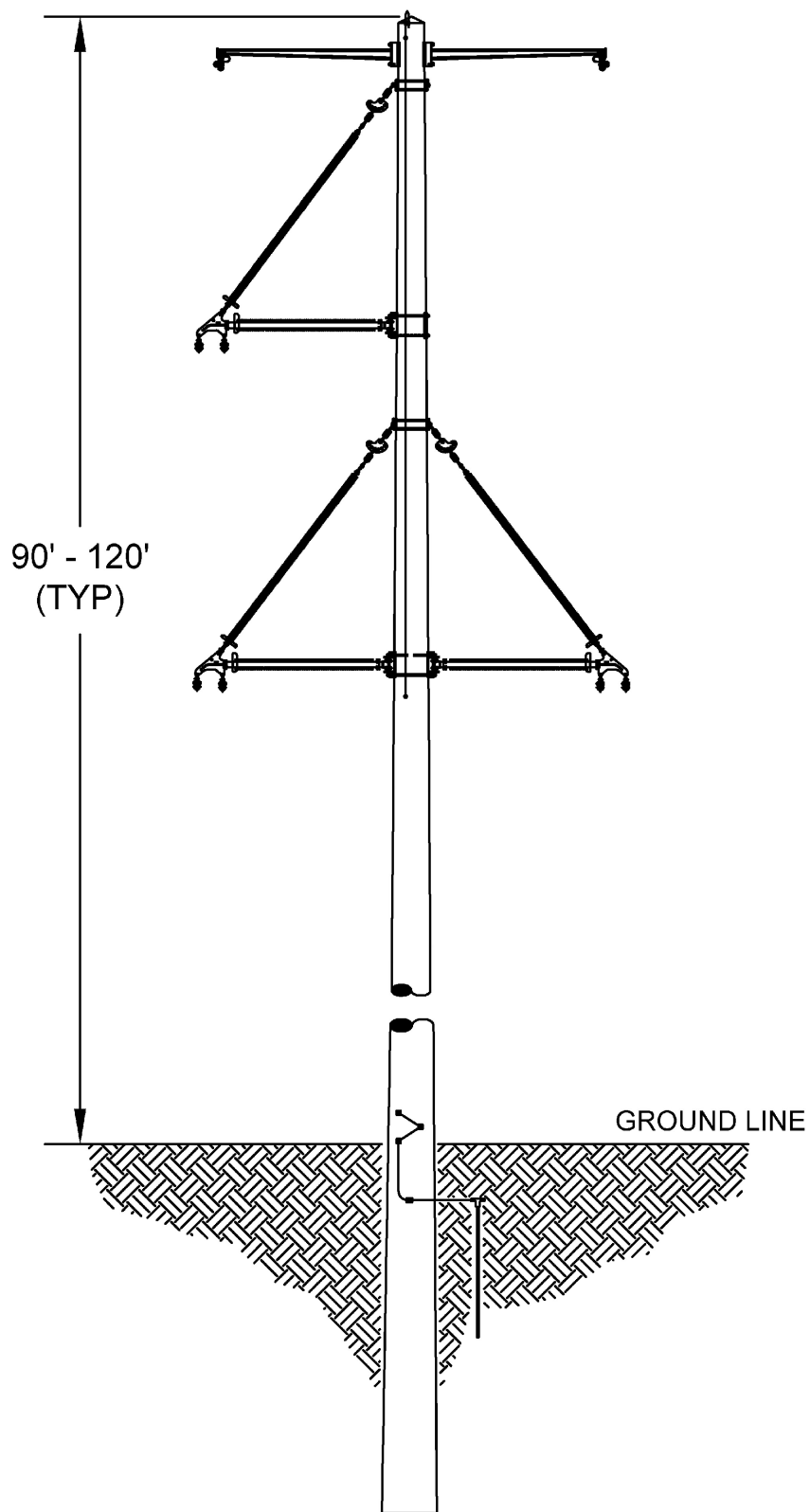

Source: Lone Star Transmission; Burns & McDonnell Engineering Company, Inc
Path: \\dalsr\data\Projects\ESP\LONE STAR TRANSMISSION\Roadrunner_345kV\Geospatial\DataFiles\ArcDocs\RX2RS_Figure_1_2_Typical_Tangent.mxd_gacox_6/16/2020



Figure 1-2
Typical Monopole Tangent Structure
Reata Station to Roadrunner Crossing Wind
345 kV Transmission Line
Lone Star Transmission

Source: Lone Star Transmission; Burns & McDonnell Engineering Company, Inc
Path: \\dalsr\data\Projects\ESP\LONE STAR TRANSMISSION\Roadrunner_345kV\Geospatial\DataFiles\ArcDocs\RX2RS_Figure_1_3_Typical_DeadendAngle.mxd_gacox_6/16/2020

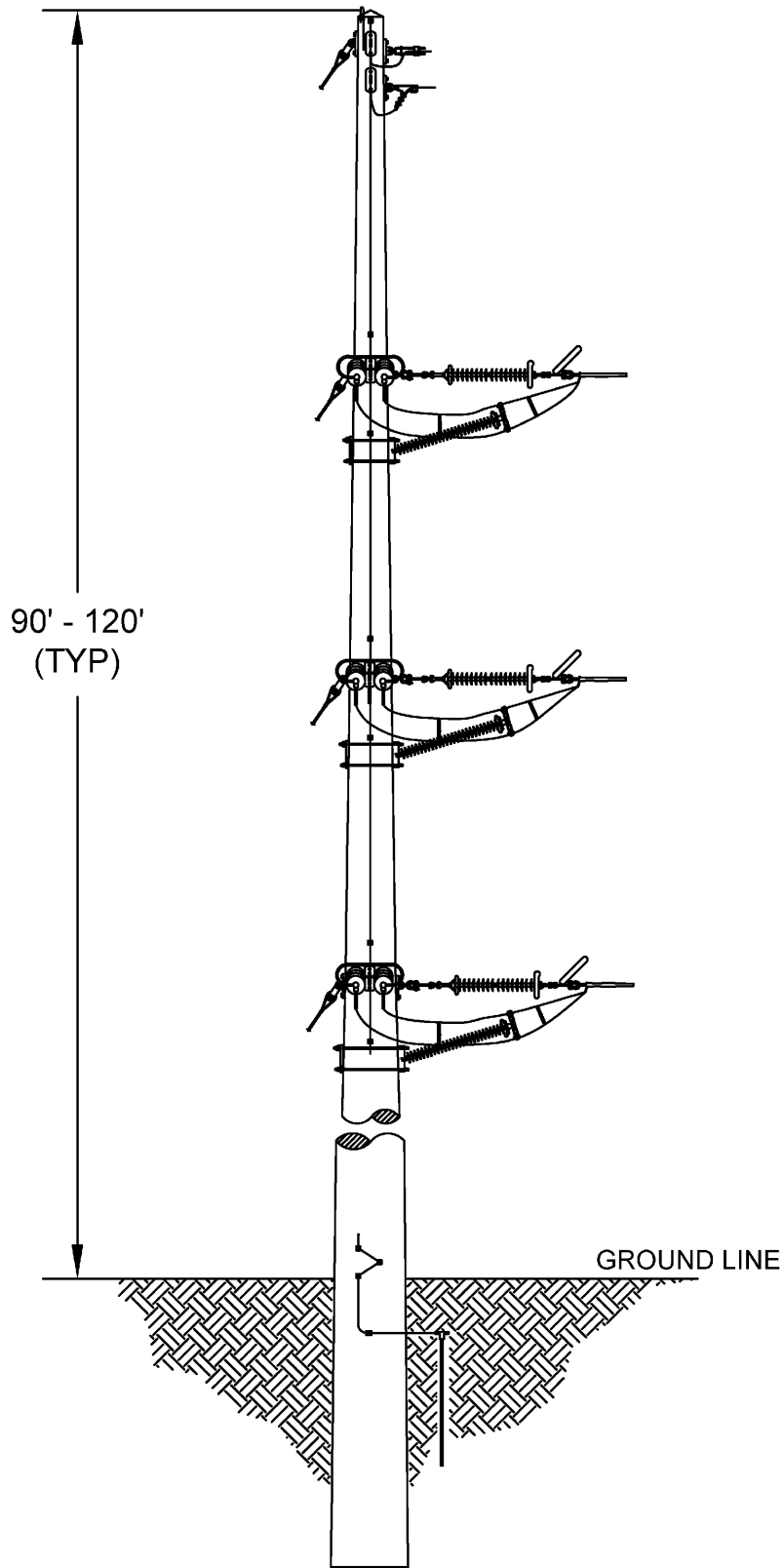

Figure 1-3
Typical Monopole Deadend Structure
Reata Station to Roadrunner Crossing Wind
345 kV Transmission Line
Lone Star Transmission

1.3.3 Right-of-Way Requirements

Lone Star and Roadrunner Crossing Wind are working together to obtain consent for the proposed project and its location parallel to CR 126. The proposed ROW width for this Project will be approximately 100 to 150 ft. The proposed transmission line will be generally located along the centerline of the ROW. In some areas the line may be located slightly to the east but within the 150-foot ROW. Additional ROW may be required at the two turning structures to accommodate guy wires where utilized. Temporary ROW may be required at line angles and at dead-ends to facilitate construction.

1.4 Construction Considerations

Projects of this type require surveying, ROW clearing and access improvements, foundation installation, structure assembly and erection, conductor and shield wire installation, and cleanup when the Project is completed.

1.4.1 Clearing

After regulatory approval and design of the transmission line are final, ROW will be acquired and cleared. Any required clearing of the ROW will be performed by the contractor according to Lone Star clearing specifications under the direction of Lone Star. Available methods of disposal are mulching, brush piling, and salvaging.

The ROW will be used for access during construction operations. To access the ROW, Lone Star may have to cross private property that adjoins the ROW. In general, however, Lone Star will access the ROW from the public county road, CR 126, that runs parallel to the transmission line. Gates may be installed to facilitate linear access as required. Culverts will be installed to cross creeks and tributaries, where necessary, for construction purposes.

Clearing plans, methods, and practices are extremely important for success in any program designed to minimize the adverse effects of electric transmission lines on the natural environment. The following measures, thoughtfully implemented and applied to this Project, will help meet this goal:

1. Clearing will be performed in a manner that will maximize the preservation of natural habitat and the conservation of natural resources.
2. Clearing will be performed in a manner that will minimize adverse effects to waters in the area of activity.
3. The time and method of clearing ROW will take into account soil stability, the protection of natural vegetation, sensitive habitats, the protection of adjacent resources such as natural habitat for plants and wildlife, and the prevention of silt deposition in watercourses.

4. Lone Star will use the most efficient and effective methods to remove undesirable plant species. Hydro-axes and flail mowers may be used in clearing operations where such use will preserve the cover crop of grass and similar vegetation. If deemed appropriate, U.S. Environmental Protection Agency (EPA)-approved herbicides will be applied and handled in accordance with the product manufacturers' published recommendations and specifications and as directed by appropriate qualified staff.

1.4.2 Construction

The following is a description of typical construction methods for transmission line projects. Survey crews will stake the boundaries of the ROW and mark structure locations. Depending on soil type, crews will typically direct-embed structures or pour foundations using augured circular holes, rebar cages, and anchor bolts.

Crews will transport and assemble structures and related hardware. Where direct-embedded structures are used, crews will install them by boring appropriately sized holes, lifting and setting the structure, and backfilling with select fill, depending on soil conditions at the site (based on soils testing). Where foundations are poured and have cured sufficiently, crews will set the structures. The usual procedure is to assemble each structure on its side, then lift the structure and set it on its base. Construction crews will take care to minimize damage to the ROW from vehicular traffic.

Guard structures (temporary wood-pole structures) will be installed near crossings, such as distribution power lines, overhead telephone lines, roadways, and any other areas where a safety hazard may be present during wire installation. The conductors and shield wires are installed via a tensioning system. A rope is first threaded through the stringing blocks or dollies, which is then used to pull through a steel cable. Conductors and shield wires are then pulled by the steel cables and held tight by a tensioner, which keeps the wires from touching the ground and other objects that could be damaging to the wires. When each wire is tensioned to the required sag, the wire is taken out of the blocks and placed in the suspension and dead-end clamps for permanent attachment.

Construction operations will be conducted with attention to the preservation of the natural habitat and the conservation of natural resources. The following criteria will be used to attain this goal. These criteria are subject to adjustment according to the rules and judgments of any public agencies whose lands may be crossed by the proposed line.

1. Clearing and grading of construction areas, such as storage areas and setup sites, will be minimized. These areas will be graded in a manner that will minimize erosion and conform to the natural topography.
2. Soil that has been excavated during construction and not used will be evenly backfilled onto a cleared area or removed from the site. The backfilled soil will be sloped gradually to conform to the terrain and the adjacent land. If natural seeding will not provide ground cover in a reasonable length of time, appropriate reseeding will be performed.
3. Erosion control devices will be constructed where necessary to reduce soil erosion in the ROW.
4. Clearing and construction activities near streambeds will be performed in a manner to minimize damage to the natural condition of the area. Streambanks will be restored as necessary to minimize erosion.
5. Efforts will be made to prevent accidental oil spills and other types of pollution, particularly while performing work near streams, lakes, and reservoirs.
6. Precautions will be taken to prevent the possibility of accidentally starting range fires.
7. Precautions will be taken to protect natural features and cultural resources (identified by site-specific review of the Project) along the ROW.
8. If endangered or threatened species habitat is present, guidance from the U.S. Fish and Wildlife Service (USFWS) will be obtained prior to all clearing and construction activities.
9. Soil disturbance during construction will be kept to a minimum, and restorative measures will be taken in a reasonable length of time.
10. Lone Star will comply with any applicable permit or regulatory approval.

1.4.3 Cleanup

The cleanup operation involves the leveling of all disturbed areas, the removal of all construction debris, and the restoration or compensation of any items damaged by the construction of the Project. The following criteria generally apply to the cleanup of construction debris and the restoration of the area's natural setting.

1. If site factors make it unusually difficult to establish a protective vegetative cover, other restoration procedures will be used, such as the use of gravel, rocks, or concrete to restore areas disturbed during construction.
2. Scars, cuts, fill, or other aesthetically degraded areas will be allowed to seed naturally or may be reseeded with native species to reduce erosion, restore a natural appearance, and to provide food and cover for wildlife.
3. If access roads are removed after construction, the original slopes will be restored where possible.

4. Construction equipment and supplies will be dismantled and removed from the ROW when construction is completed.
5. Clearing down to the mineral soil may be required for road access. In this case, water diversion berms, velocity dissipaters, or other erosion control devices will be used to reduce erosion potential.
6. Construction waste will be removed prior to completion of the Project.
7. Replacement of soil adjacent to water crossings for access roads will be at slopes less than the normal angle of repose for the soil type involved and will be stabilized/revegetated to avoid erosion.
8. Lone Star will comply with any applicable permit or regulatory approval.

1.5 Maintenance Considerations

Following construction of the transmission line, Lone Star will require periodic access to the ROW for inspection of the line and repair of damaged structures due to equipment failures, accidents, or natural phenomena, such as wind or lightning damage. In areas where treatment of vegetation within the ROW is required, mowing, pruning and application of EPA-approved herbicides will be conducted as required. While maintenance patrols will vary, aerial and foot patrols will be performed periodically. In cropland areas and properly managed grazing lands, little or no vegetation control will be required, due to existing land-use practices. The major maintenance item will be the trimming or removal of trees that pose a potential danger to the conductors or structures to provide a safe and reliable power line.

1.6 Agency Actions

Numerous Federal, State, and local regulatory agencies and organizations have promulgated rules and regulations regarding the routing and potential impacts associated with the proposed transmission line Project. This section lists the major regulatory agencies that are involved in project planning and permitting of transmission lines in Texas, and describes the permits or approvals required. Burns & McDonnell solicited comments from various regulatory agencies and officials during the development of this document. A summary of agency responses is provided in Section 5.1 (Correspondence with Agencies and Officials) and copies of the responses received are included in Appendix A (Agency Correspondence).

Construction documents and specifications will indicate special construction measures needed to comply with the regulatory requirements listed below.

1.6.1 Public Utility Commission of Texas

The PUC regulates the routing of transmission lines in Texas under PURA § 37.056. The Project will require Lone Star to file an application to amend its CCN with the PUC. This EA has been prepared by Burns & McDonnell in support of Lone Star's CCN application for this Project. The EA is intended to provide information on certain environmental and land use factors identified in PURA § 37.056(c)(4) and 16 TAC § 25.101(b)(3)(B), as well as to address relevant questions in the PUC's CCN application form. This report may also be used in support of any local, State, or Federal permitting requirements, if necessary. Lone Star will obtain PUC approval of its CCN application prior to beginning construction of the Project.

1.6.2 Federal Aviation Administration

According to Federal Aviation Administration (FAA) regulations (FAR), Part 77, the construction of a transmission line requires FAA notification if structure heights exceed 200 ft. or the height of an imaginary surface extending outward and upward at one of the following slopes (FAA, 2011):

- A 100:1 slope for a horizontal distance of 20,000 ft. from the nearest point of the nearest runway of a public or military airport having at least one runway longer than 3,200 ft.
- A 50:1 slope for a horizontal distance of 10,000 ft. from the nearest runway of a public or military airport where no runway is longer than 3,200 ft. in length
- A 25:1 slope for a horizontal distance of 5,000 ft. for heliports

Based on these guidelines, Lone Star will make a final determination of the need for FAA notification based on the alignment of the approved route, structure locations, and structure designs. If necessary, Lone Star will file a "Notice of Proposed Construction or Alteration" (Form 7460-1) with the FAA at least 30 days prior to construction. The result of this notification and the subsequent coordination with the FAA could include changes in the design or potential requirements to mark or illuminate portions of the line.

1.6.3 U.S. Army Corps of Engineers

Under Section 404 of the Clean Water Act (CWA), activities in waters of the U.S., including wetlands, are regulated by the U.S. Army Corps of Engineers (USACE), in conjunction with the EPA. Certain construction activities that potentially impact waters of the U.S. may be authorized by one of the USACE's Nationwide Permits (NWP). Permits that may apply to placement of support structures and associated activities are NWP 25 (Structural Discharges) and NWP 12 (Utility Line Activities).

NWP 12 generally authorizes discharges associated with the construction of utility lines and substations within waters of the U.S. and additional activities affecting waters of the U.S., such as those associated with the construction and maintenance of utility line substations; foundations for overhead utility line towers, poles, and anchors; and access roads for the construction and maintenance of utility lines. Construction of this transmission line Project will likely meet the criteria of NWP 12. For this Project, potential wetlands will be easily spanned by the transmission line and, therefore, impacts to waters of the U.S. are not anticipated. If necessary, Lone Star will coordinate with the USACE prior to clearing and construction to ensure compliance with the appropriate regulations associated with construction-related impacts to waterbodies and wetland features.

Under Section 10 of the Rivers and Harbors Act of 1899, 33 U.S.C. § 403, the USACE is directed by Congress to regulate all work and structures in, or affecting the course, condition, or capacity of navigable waters of the U.S., including tidal waters. No navigable waters occur within the Study Area that would require permitting under this Act.

1.6.4 U.S. Fish and Wildlife Service

The USFWS enforces Federal wildlife laws and provides comments on proposed projects under the jurisdiction of the Endangered Species Act (ESA), Migratory Bird Treaty Act (MBTA), and Bald and Golden Eagle Protection Act (BGEPA). Additionally, USFWS oversight includes review of projects with a Federal nexus under the National Environmental Policy Act (NEPA).

Upon PUC approval of the proposed Project, a survey may be necessary to identify any potential suitable habitat for federally protected species. If suitable habitat is noted, then informal consultation with the USFWS may be conducted to determine if permitting or other requirements associated with possible impacts to protected species under the ESA, MBTA, or BGEPA is necessary. However, no impacts are expected to any federally listed or proposed federally listed species, and consultation with USFWS is not expected to be necessary.

1.6.5 Federal Emergency Management Agency

Burns & McDonnell reviewed the Flood Insurance Rate Map (FIRM), published by the Federal Emergency Management Agency (FEMA), for Eastland County. Floodplains are not extensive in the Study Area and are associated with two unnamed streams. Initial review conducted by the Eastland County Judge and Floodplain Administrator indicated that the Project should not adversely affect floodplain management. Additional coordination with the Floodplain Administrator will be completed as necessary once the route is approved and final structure locations are identified.

1.6.6 U.S. Department of Defense Siting Clearinghouse

The U.S. Department of Defense (DoD) Siting Clearinghouse works with industry to overcome risks to national security while promoting compatible domestic energy development. Energy production facilities and transmission projects involving tall structures, such as electric transmission towers, may degrade military testing and training operations. The electromagnetic interference from electric transmission lines can impact critical DoD testing activities. PUC Procedural Rule 22.52 states that the “[A]pplicant shall, upon filing of the application, also mail notification of [its] application to... and the Department of Defense Siting Clearinghouse.” An affidavit attesting to the notification to the DoD is also required. Furthermore, the utility is required to provide written notice of the public meeting or, if no public meeting is held, to provide written notice to the DoD of the planned filing of an application prior to completion of the routing study. Lone Star sent a letter to the DoD Siting Clearinghouse on April 24, 2020 notifying it of the Project and that Lone Star was preparing an EA and CCN application. Lone Star will also provide notice of the filing of the application to the DoD Siting Clearinghouse upon the filing of its CCN application.

1.6.7 Texas Parks and Wildlife Department

The Texas Parks and Wildlife Department (TPWD) is the State agency with the primary responsibility of protecting the State’s fish and wildlife resources in accordance with the Texas Parks and Wildlife Code Section 12.0011(b). Burns & McDonnell solicited comments from the TPWD during the Project scoping phase. PUC Procedural Rule 22.52 requires the Applicant to “provide a copy of each environmental impact study and/or assessment for the project to [TPWD] within seven days of filing the application.” Therefore, a copy of this EA will be submitted to TPWD when the CCN application is filed with the PUC. An affidavit attesting to the notification to TPWD is also required. Once the PUC approves a route, additional coordination with TPWD may be necessary to determine the need for additional surveys and to avoid or minimize any potential adverse impacts to sensitive habitats, threatened or endangered species, and other fish and wildlife resources.

1.6.8 Texas Commission on Environmental Quality

The Project may require a Texas Pollution Discharge Elimination System (TPDES) General Construction Permit (TX150000) as implemented by the Texas Commission on Environmental Quality (TCEQ) under the provisions of Section 402 of the CWA and Chapter 26 of the Texas Water Code. The TCEQ has developed a three-tiered approach for implementing this permit that is dependent on the acreage of disturbance. No permitting is required for land disturbance of less than one acre (Tier I). Disturbance of more than one acre, but less than five acres, would require implementation of a Storm Water Pollution

Prevention Plan (SWPPP) (Tier II). If more than five acres of land are disturbed, the requirements mentioned above for Tier II are necessary, and the submittal of a Notice of Intent (NOI) and Notice of Termination (NOT) to the TCEQ are also required (Tier III). Once a route is approved by the PUC, Lone Star will determine the amount of ground disturbance and the appropriate tier and conditions of the TX150000 permit.

1.6.9 Texas Department of Transportation

Permits and approvals are required from the Texas Department of Transportation (TxDOT) if a proposed transmission line requires the crossing of, or access from, a State-maintained roadway. The Consensus Route, however, will not cross or require access from a State-maintained roadway, and therefore, no permits or approvals from TxDOT are anticipated to be needed for the Project.

1.6.10 Texas Historical Commission

Cultural resources are protected by Federal and State laws if they have some level of significance under the criteria of the National Register of Historic Places (NRHP) (36 Code of Federal Regulations [CFR] Part 60) or under State guidance (TAC, Title 13, Part 2, Chapter 26.7-8). Lone Star will obtain clearance as necessary from the Texas Historical Commission (THC) regarding requirements concerning historic and prehistoric cultural resources, if present, prior to initiating any ground disturbance.

1.6.11 Texas General Land Office

The Texas General Land Office (GLO) requires a Miscellaneous Easement (ME) for any ROW crossing a State-owned riverbed, navigable stream, tidally influenced water, or Permanent School Fund Lands. Following PUC approval of a route for this Project, if any such waters or lands are crossed, Lone Star will obtain the necessary ME. However, a ME is not expected to be required for this Project, since the Consensus Route will likely not cross any State-owned riverbed, navigable stream, tidally influenced water, or Permanent School Fund Lands.

1.6.12 Eastland County

Floodplain permits and county road crossing permits or approvals will be obtained from Eastland County as required. As noted above, initial review conducted by the Eastland County Judge and Floodplain Administrator indicated that the Project should not adversely affect floodplain management. Additional coordination with the Floodplain Administrator will be completed as necessary once the route is approved and final structure locations are identified.

2.0 ROUTE EVALUATION METHODOLOGY

2.1 Objective of Study

The objective of this study was to evaluate the potential environmental and land use impacts for Lone Star's proposed 345 kV transmission line Project to ensure that it complies with PURA § 37.056(c)(4)(A)-(D), 16 TAC § 22.52(a)(4), and 16 TAC § 25.101(b)(3)(B), including the PUC's policy of prudent avoidance. Lone Star and Burns & McDonnell utilized a comprehensive and well-established evaluation methodology to evaluate potential impacts of the proposed transmission line route. Methods used to evaluate the route were governed by Burns & McDonnell's transmission line routing criteria, the PUC Substantive Rules, and PURA. The following sections provide a description of the process used in the development and evaluation of the proposed transmission line route (Consensus Route).

2.2 Data Collection

Data used by Burns & McDonnell in the evaluation of the Project were drawn from a variety of sources, including published literature (*e.g.*, documents, reports, maps, aerial photography), information from local, State, and Federal agencies, and site-specific studies or investigations performed by others. Recent aerial imagery (2018 ESRI Maxar WorldView-3 Satellite imagery; 2019 United States Department of Agriculture [USDA] National Agriculture Imagery Program [NAIP]; 2019 Google Earth), Google Maps, 7.5-minute U.S. Geological Survey (USGS) topographic maps (Bernie Lake [1966, 2010, 2012]), USFWS National Wetlands Inventory (NWI) maps, USFWS's Information, Planning, and Conservation (IPaC) system, TPWD's Natural Diversity Database (NDD), TPWD's Ecological Mapping Systems of Texas (EMST), and ground reconnaissance surveys were used throughout the development and evaluation of alternative routes. Ground reconnaissance of the Study Area and computer-based evaluation of digital aerial imagery were used throughout the evaluation of the Project. The data collection effort, although concentrated in the early stages of the Project, was an ongoing process that continued throughout the preparation of the EA.

2.3 Evaluation of the Route

2.3.1 Study Area Delineation

The first step in the assessment of the Project was to delineate a Study Area. The Study Area needed to encompass the endpoints for the proposed Project (Lone Star's proposed Reata Station and the proposed Roadrunner Crossing Wind Collector Substation) and include an area large enough to adequately evaluate the proposed transmission line Project in support of Lone Star's CCN Application. The purpose of delineating a Study Area for the Project was to establish boundaries and limits in which to identify

environmental and land use constraints during the information gathering process to properly identify and map various items included within the PUC's CCN application. The delineated Study Area measures approximately 3.5 miles north to south and one mile east to west, and encompasses an area of 3.5 square miles (2,240 acres), primarily in Eastland County. The westernmost extent of the Study Area is located in Callahan County (Figure 2-1).

2.3.2 Constraints Mapping

To quantify potential impacts to sensitive environmental and land use features, a constraints mapping process was used in evaluating the Project. The geographic locations of environmentally sensitive and other restrictive areas within the Study Area were identified and considered during the evaluation process. These constraints were mapped onto an aerial base map (Figure 2-2, map pocket) created using 2019 NAIP imagery and 2018 ESRI Maxar WorldView-3 Satellite imagery.

2.3.3 Evaluation Factors

The evaluation of the Project involved studying a variety of environmental factors. The Project was examined in the field in April 2020. The field investigation of the Study Area and Consensus Route was conducted from publicly accessible areas. In evaluating the Consensus Route, 38 environmental criteria were considered. These criteria are presented in Table 2-1.

The analysis of the Project involved the inventory and tabulation of the number or quantity of each environmental criterion located along the Consensus Route (*e.g.*, number of habitable structures within 500 ft., length parallel to compatible ROW, amount of brushland/shrubland crossed, etc.). The number or amount of each criterion was determined by reviewing various maps and recent color aerial imagery (2019 NAIP and Google Maps), and by field verification. Potential environmental impacts of the Consensus Route are addressed in Section 4.0 of this document.

Callahan
County

Eastland
County

CR 314

CR 125

Proposed Roadrunner
Crossing Wind
Collector Station

CR 126

CR 107

West Shackelford to Sam Switch 345 kV Line

CR 128

Proposed Reata Station

CR 303

CR 126

FM 2945

- Project Endpoint
- Existing Transmission Line
- ▭ Study Area

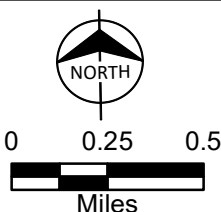

Figure 2-1
Study Area
Reata Station to
Roadrunner Crossing Wind
345 kV Transmission Line
Lone Star Transmission
Eastland County, Texas

Path: \\dalsv\data\Projects\ESP\ONE STAR TRANSMISSION\Roadrunner 345kV\Geospatial\DataFiles\ArcDocs\RX2RS_Figure 2_1_StudyArea.mxd gacox 6/16/2020
Service Layer Credits: Source: Esri, DigitalGlobe, GeoEye, Earthstar Geographics, CNES/Airbus DS, USDA, USGS, AeroGRID, IGN, and the GIS User Community

Figure 2-2: Environmental and Land Use Constraints Within the Study Area

This oversized map is located in a map pocket in the back of this document.

**Table 2-1: Environmental Criteria for Reata Station to Roadrunner Crossing Wind
345 kV Transmission Line Project**

No.	Environmental Criterion
Land Use	
1	Length of route
2	Number of habitable structures ^a within 500 ft. of ROW centerline
3	Length of ROW utilizing existing transmission line ROW
4	Length of ROW parallel to existing transmission line ROW
5	Length of ROW parallel to other existing compatible ROW (roads, highways, railways, etc.) ^b
6	Length of ROW parallel to approximate property lines (not following existing ROW) ^c
7	Length of ROW across parks/recreational areas ^d
8	Number of additional parks/recreational areas ^d within 1,000 ft. of ROW centerline
9	Length of ROW across cropland
10	Length of ROW across pastureland/rangeland
11	Length of ROW across cropland or pastureland with mobile irrigation systems
12	Number of pipeline crossings
13	Number of oil/gas wells within ROW
14	Number of transmission line crossings
15	Number of U.S. and State highway crossings
16	Number of Farm-to-Market (FM)/Ranch-to-Market (RM) road crossings
17	Number of FAA-registered airfields within 20,000 ft. of ROW centerline (with runway >3,200 ft.)
18	Number of FAA-registered airfields within 10,000 ft. of ROW centerline (with runway <3,200 ft.)
19	Number of private airstrips within 10,000 ft. of ROW centerline
20	Number of heliports within 5,000 ft. of ROW centerline
21	Number of commercial AM radio transmitters within 10,000 ft. of ROW centerline
22	Number of FM radio transmitters, microwave towers, and other electronic installations within 2,000 ft. of ROW centerline
Aesthetics	
23	Estimated length of ROW within foreground visual zone ^e of U.S. and State highways
24	Estimated length of ROW within foreground visual zone ^e of FM/RM roads
25	Estimated length of ROW within foreground visual zone ^e of parks/recreational areas ^c
Ecology	
26	Length of ROW through brushland/shrubland
27	Length of ROW through riparian brushland/shrubland
28	Length of ROW across potential wetlands ^f
29	Length of ROW across known occupied habitat of federally endangered or threatened species

30	Number of stream crossings
31	Length of ROW parallel (within 100 ft.) to streams
32	Length of ROW across open water (ponds, etc.)
33	Length of ROW across 100-year floodplains
Cultural Resources	
34	Number of recorded cultural resource sites crossed by ROW
35	Number of additional recorded cultural resource sites within 1,000 ft. of ROW centerline
36	Number of NRHP-listed or determined-eligible sites crossed by ROW
37	Number of additional NRHP-listed or determined-eligible sites within 1,000 ft of ROW centerline
38	Length of ROW crossing areas of high archeological/historical site potential

All length measurements in feet.

^aSingle-family and multi-family dwellings and related structures, mobile homes, apartment buildings, commercial structures, industrial structures, business structures, churches, hospitals, nursing homes, schools, or other structures normally inhabited by humans or intended to be inhabited by humans on a daily or regular basis.

^bFor purposes of this evaluation, pipelines were not considered a compatible corridor.

^cProperty lines created by existing road, highways, or railroad ROW are not “double-counted” in the “length of route parallel to property lines” criterion.

^dDefined as parks and recreational areas owned by a governmental body or an organized group, club, or church.

^e0.5 mile, unobstructed.

^fAs mapped by the U.S. Fish and Wildlife Service National Wetland Inventory.

3.0 EXISTING ENVIRONMENT

3.1 Physiography

As shown on Figure 3-1, the Study Area is located within the North-Central Plains Physiographic Province (Bureau of Economic Geology [BEG], 1996), which occurs in the north-central portion of the State east to the High Plains, north to Oklahoma and the Canadian Breaks of the Central High Plains, east to the Grand Prairie, and south to the Edwards Plateau and Central Texas Uplift provinces.

The North-Central Plains of Texas form low north-south ridges (questas) ranging from 900 to 3,000 ft. in elevation above mean sea level (msl). This area has an erosional surface that developed on upper Paleozoic formations, and where shale bedrock prevails, meandering rivers traverse stretches of local prairie. In areas of harder bedrock, hills and rolling plains dominate, and local areas of hard sandstones and limestone cap steep slopes severely dissected near rivers. Western rocks and soils are oxidized red or gray where gypsum dominates, whereas eastern rocks and soils weather tan to buff (BEG, 1996). Study Area elevations range from a high of approximately 1,616 ft. above msl in the south-central portion of the Study Area to a low of 1,459 ft. above msl in the northwestern corner of the Study Area.

3.2 Geology

According to BEG (1972), the Study Area includes the following geologic units (from youngest to oldest): Quaternary-aged alluvium, Permian-aged Moran Formation, and Moran Formation. Quaternary-aged alluvium is associated with the larger unnamed creeks within the Study Area and consist of floodplain deposits, which include low terrace deposits near floodplain level and bedrock locally in stream channels with a thickness up to 25 ft.

The Permian-aged Moran Formation is present in the majority of the Study Area and consists of mudstone, sandstone, and limestone; however, it is mostly mudstone, which is tan, poorly exposed, with fine-grained sheet sandstone in the middle, which is cross-bedded and locally burrowed. Additional areas scattered within the Study Area within the Moran Formation containing sandstone and mudstone. These areas contain sandstone units approximately 5 to 12 ft thick that are gray to brown, fine- to medium-grained, ripple-marked, and cross-bedded, with only the broad dip slopes mapped and a thickness, including mudstone, at approximately 20 to 40 ft. No reported geologic faults occur in the Study Area or in the immediate vicinity of the Study Area.

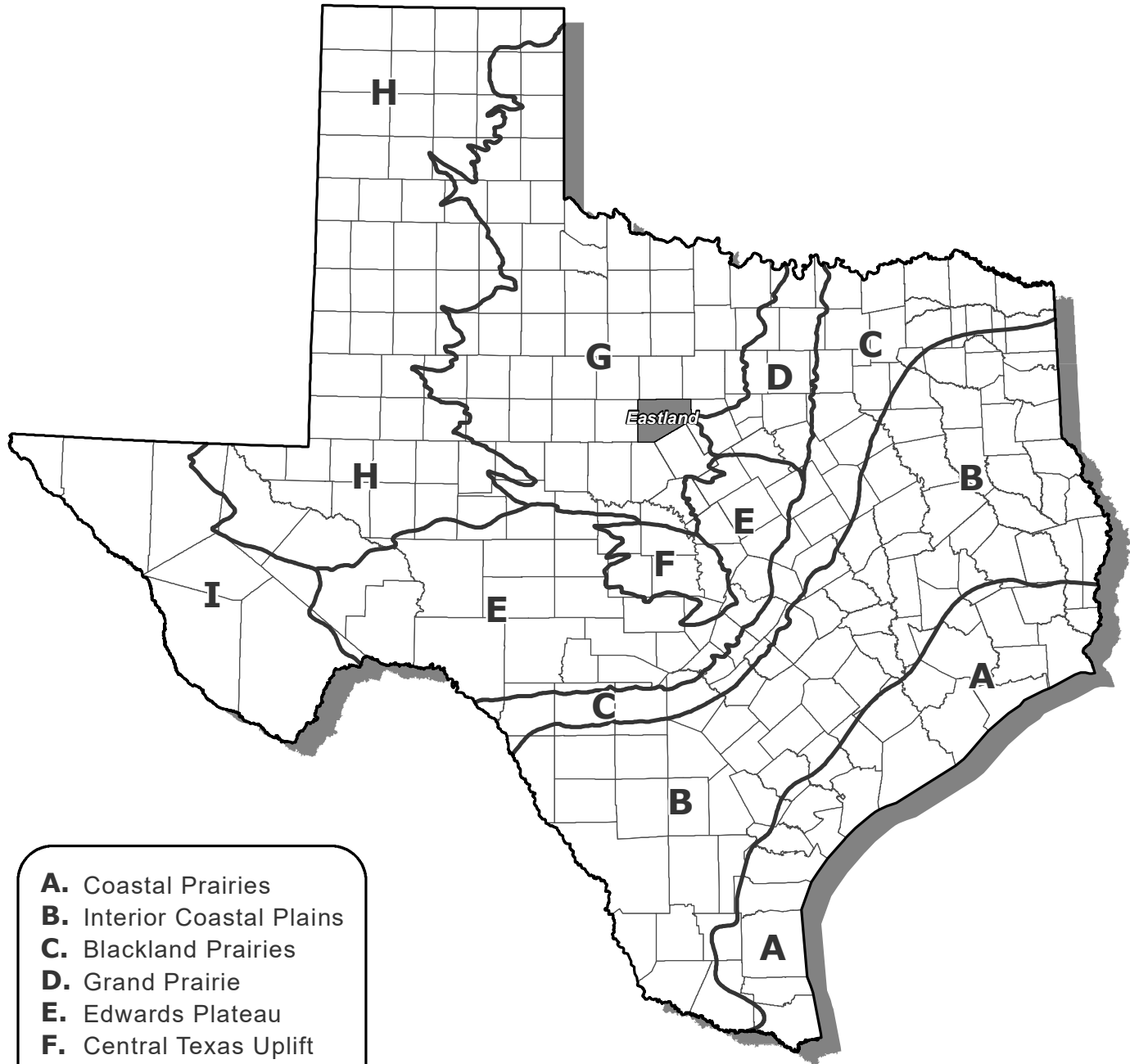

- A.** Coastal Prairies
- B.** Interior Coastal Plains
- C.** Blackland Prairies
- D.** Grand Prairie
- E.** Edwards Plateau
- F.** Central Texas Uplift
- G.** North-Central Plains
- H.** High Plains
- I.** Basin and Range

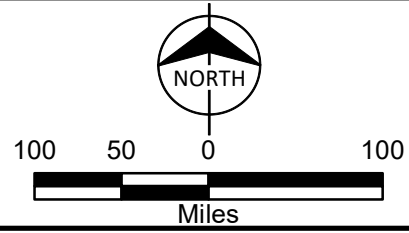

Figure 3-1
Location of Eastland County
in Relation to the
Physiographic Provinces of Texas
Reata Station to
Roadrunner Crossing Wind
345 kV Transmission Line

Path: \\data\projects\ESP\ONE STAR TRANSMISSION\Roadrunner 345kV\Geospatial\DataFiles\ArcDocs\RX2RS_Figure_3_1_Physiographic_Provinces_Map.mxd gacox 6/16/2020
COPYRIGHT © 2020 BURNS & McDONNELL ENGINEERING COMPANY, INC.

3.3 Soils

The Study Area occurs within northwestern Eastland County and a small portion of northeastern Callahan County. The general soil map of Eastland County, published by the Soil Conservation Service (SCS) (now renamed as the Natural Resources Conservation Service (NRCS)) in 1977, and the general soil map of Callahan published in 1981, were referenced for the following descriptions of the general soil map units within the Study Area.

3.3.1 Soil Associations

The NRCS defines a soil association as “a group of soils geographically associated in a characteristic repeating pattern and defined and delineated as a single map unit.” A soil association typically consists of one or more major soils, for which it is named, and some minor soils. Soils making up one unit can also occur in other units in a different pattern. According to the Eastland County (SCS, 1977) and Callahan County (SCS, 1981) Soil Maps, three general soil associations/map units occur within the Study Area.

The Truce-Thurber-Leeray association, which comprises the majority of the Study Area, is characterized by nearly level to gently sloping, deep, loamy, and clayey over limy clay or shale and makes up approximately 10 percent of the county. It is located on ridges and in adjacent broad, shadow valleys and contains approximately 42 percent Truce soils, 22 percent Thurber soils, 17 percent Leeray soils, and 19 percent minor soils. These soils are used mainly for range (SCS, 1977).

The Tarrant-Bolar association, which occurs in the northeastern portion of the Study Area, consists of gently sloping to sloping and hilly, very shallow to moderately deep, clayey and loamy soils over limestone. It encompasses approximately 7 percent of the county and contains approximately 42 percent Tarrant soils, 17 percent Bolar soils, and 41 percent minor soils. Most of the acreage is used for range and a few areas of Bolar soils are cultivated (SCS, 1977).

The Leeray-Sagerton-Nukrum soil map unit, which is only located in the western portion of the Study Area in Callahan County, consists of deep, nearly level to gently sloping, clayey and loamy soils on uplands. Slopes range from 0 to approximately 5 percent and contain approximately 24 percent Leeray soils, 23 percent Sagerton soils, 17 percent Nukrum soils, and 36 percent other soils. Areas of this map unit are used as cropland, pastureland, and rangeland (SCS, 1981).

3.3.2 Prime Farmland Soils

The Secretary of Agriculture, in 7 USC § 4201(c)(1)(A), defines prime farmland soils as those soils that have the best combination of physical and chemical characteristics for producing food, feed, forage, fiber, and oilseed crops. They have the soil quality, growing season, and moisture supply needed to

economically produce sustained high yields of crops when treated and managed, including water management, according to acceptable farming methods. Additional potential prime farmlands are those soils that meet most of the requirements of prime farmland but fail because they lack sufficient natural moisture, or they lack the installation of water management facilities. Such soils would be considered prime farmland if these practices were installed.

According to the NRCS (2019), prime farmland soils comprise approximately 31 percent (688 acres) of the Study Area, with an additional 13 percent (294 acres) included if irrigated. In addition, 15 percent (336 acres) is included as farmland of statewide importance, and 4 percent (79 acres) is included as farmland of statewide importance, if irrigated.

Eastland County encompasses 591,720 acres, of which approximately 10 percent (59,499 acres) is considered prime farmland soils, with an additional 28 percent (167,889 acres) included if irrigated. Additionally, 7 percent (42,227 acres) is included as farmland of statewide importance, and 4 percent (22,743 acres) is included as farmland of statewide importance, if irrigated. Callahan County encompasses 395,620 acres, of which approximately 25 percent (100,682 acres) is considered prime farmland soils, with an additional 8 percent (29,735 acres) included if irrigated, and 2 percent (7,590 acres) is included as farmland of statewide importance (NRCS, 2019).

3.4 Mineral and Energy Resources

According to the USGS Mineral Data Resource System reports (USGS, 2011), no active mineral quarries or mines occur in the Study Area and none were observed during field reconnaissance or while reviewing USGS topographic maps. Limestone is the only major mineral resource mapped as occurring within the Study Area (BEG, 1979) with small areas occurring in the northern and southern portions of the Study Area.

Furthermore, no energy resources are mapped within the Study Area (BEG, 1976). According to Railroad Commission of Texas (RRC), a total of 68 oil or gas wells are recorded in the Study area (31 dry hole wells, 25 plugged wells, six permitted locations, three active oil or gas wells, two cancelled/abandoned wells, and one injection/disposal well) (RRC, 2020a).

3.5 Water Resources

3.5.1 Surface Water

For surface water planning purposes, the Study Area lies within the Brazos River Basin, which is the second-largest by area in Texas, draining a total area of approximately 45,573 square miles of which 42,865 square miles are within Texas. The headwaters of the Brazos flows from the confluence of its Salt and Double Mountain forks in Stonewall County to the Gulf of Mexico. It is the third-longest river and has the largest average annual flow volume of any river in Texas. One of the main issues in this basin is the increasing demand on surface water resources in the upper basin as groundwater supplies decline, particularly in the Ogallala Aquifer, which has historically supplied the majority of water there (Texas Water Development Board [TWDB], 2020).

According to USGS topographic maps and the National Hydrography Dataset, no named surface water features (*e.g.*, streams, ponds, canals, lakes) are mapped within the Study Area. Average rainfall within the Study Area ranges from approximately 25 to 30 inches annually (TWDB, 2012).

To assist regional water planning groups in identifying sensitive stream segments under 31 TAC § 357.8, TPWD has identified ecologically significant stream segments throughout the State based on criteria pertaining to biological function, hydrological function, riparian conservation areas, water quality, aquatic life, aesthetic value, and the presence of threatened or endangered species or unique communities. No stream segments within the Study Area are designated as ecologically significant streams (TPWD, 2020a).

3.5.2 Floodplains

FEMA has conducted detailed floodplain analyses for Eastland County (FEMA, 2020); however, at the time of this report, Callahan County does not participate in the FEMA program. The resulting Flood Insurance Rate Maps (FIRMs) indicate the limits of the 100-year floodplain (areas with a 1 percent annual chance of flooding) within the Study Area. Based on FEMA mapping, 100-year floodplains are associated with the two unnamed streams within the Study Area (see Figure 2-2, map pocket).

3.5.3 Groundwater

According to the TWDB, nine major aquifers (aquifers that produce large amounts of water over large areas) and 21 minor aquifers (aquifers that produce minor amounts of water over large areas or large amounts of water over small areas) are recognized within the State of Texas. These major and minor

aquifers produce groundwater for household, municipal, industrial, and agricultural uses, and supply over 59 percent of the water used in Texas (TWDB, 2007).

The principal water-bearing unit, which occurs in the southern portion of the Study Area, is the Cretaceous-age Trinity Aquifer. A major aquifer, the Trinity is a collection of individual aquifers including the Antlers, Glen Rose, Paluxy, Twin Mountains, Travis Peak, Hensell, and Hosston Aquifers. These individual aquifers, when combined as the Trinity Aquifer, cover an area of 61 counties in Texas. These aquifers consist of limestones, sands, clays, gravels, and conglomerates, and their combined freshwater saturated thickness averages about 600 ft. in North Texas and about 1,900 ft. in Central Texas. Discharge from the aquifer occurs from water well withdrawals and springs located within streams. Groundwater yields in the Trinity Aquifer vary significantly depending on the porosity and permeability of the strata, with most springs discharging less than 10 cubic feet per second (TWDB, 2007).

3.6 Vegetation

3.6.1 Regional Vegetation

As shown on Figure 3-2, the Study Area is located within the Cross Timbers and Prairies vegetational area, which was delineated by Gould et al. (1960) and characterized by Hatch et al. (1990). The Cross Timbers and Prairies is between the Rolling Plains and the Blackland Prairies in the northern part of the State and is characterized by wide variances in geological formations, which bring about sharp contrasts in topography, soils, and vegetation. Climax vegetation is composed primarily of big bluestem (*Andropogon gerardii*), little bluestem (*Schizachyrium scoparium*), Indiangrass (*Sorghastrum nutans*), switchgrass (*Panicum virgatum*), Canada wildrye (*Elymus canadensis*), minor amounts of sideoats grama (*Bouteloua curtipendula*), blue grama (*Bouteloua gracilis*), Texas wintergrass (*Nassella leucotricha*), and buffalograss (*Bouteloua dactyloides*). Past mismanagement and cultivation have caused the uplands to be covered mostly by scrub oak (*Quercus* spp.), honey mesquite (*Prosopis glandulosa*), and juniper (*Juniperus* spp.), with mid- and shortgrass understories. Approximately 75 percent of the area is range and pasture. Major crops on the sandy Cross Timbers soils are peanuts, fruits, sorghum, wheat, oats, corn, and forages. Dairy operations are common, but beef-cattle cow-calf operations are the predominant livestock activities (Hatch et al., 1990).

3.6.2 Vegetation Community Types in the Study Area

According to TPWD's EMST vegetation cover types, approximately 27.3 percent of the Study Area consists of Native Invasive: Mesquite Shrubland, 24.7 percent as Row Crops, 18.0 percent as

Path: \\data\projects\ESP\ONE STAR TRANSMISSION\Roadrunner\345kV\Geospatial\DataFiles\ArcDocs\RX2RS_Figure_3_2_Vegetational_Areas_Map.mxd gacox 6/16/2020
COPYRIGHT © 2020 BURNS & MCDONNELL ENGINEERING COMPANY, INC.

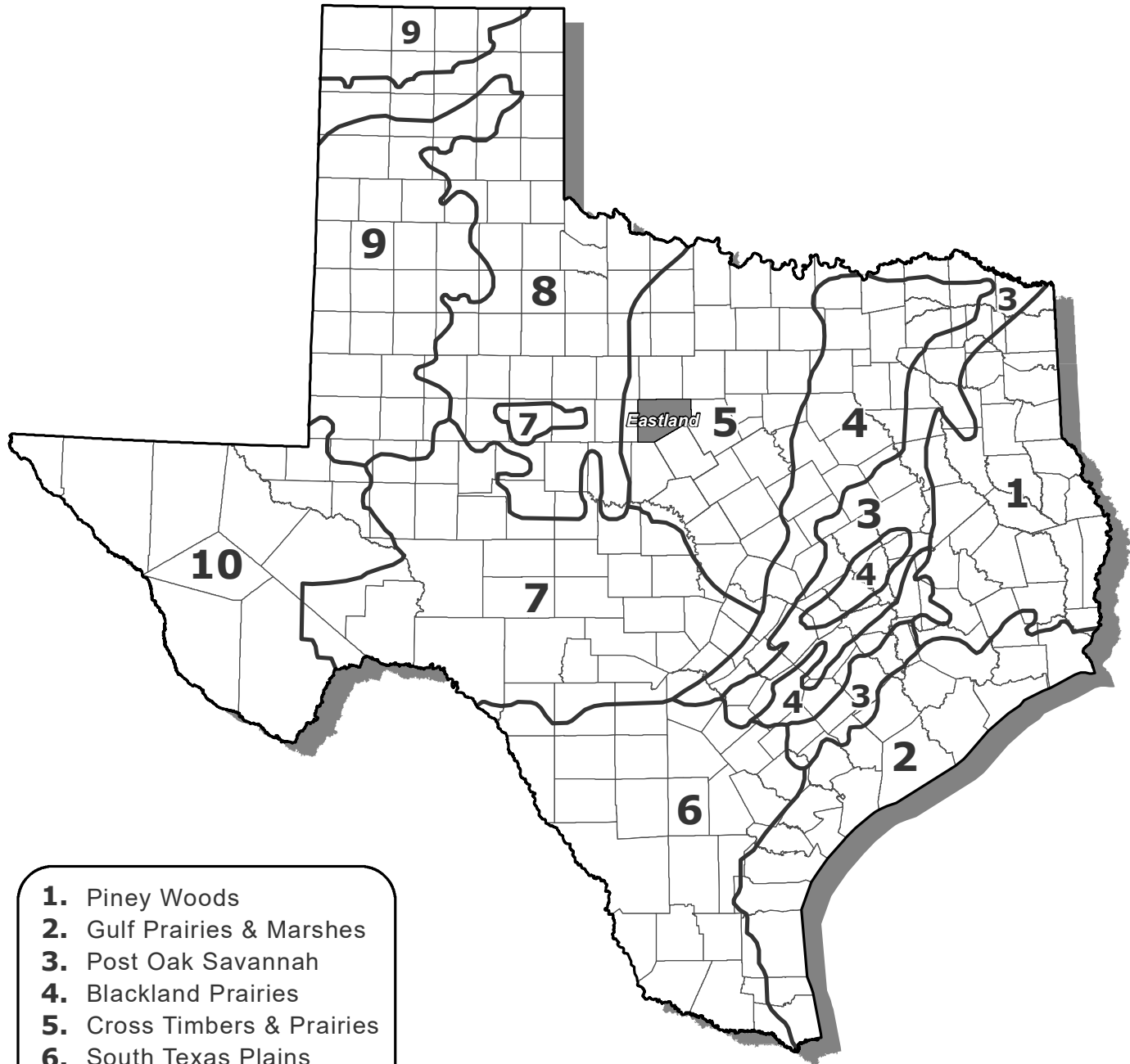

- 1. Piney Woods
- 2. Gulf Prairies & Marshes
- 3. Post Oak Savannah
- 4. Blackland Prairies
- 5. Cross Timbers & Prairies
- 6. South Texas Plains
- 7. Edwards Plateau
- 8. Rolling Plains
- 9. High Plains
- 10. Trans-Pecos

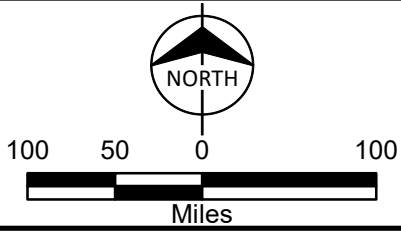

Figure 3-2
Location of Eastland County
in Relation to the
Vegetational Areas of Texas
Reata Station to
Roadrunner Crossing Wind
345 kV Transmission Line

Source: Hatch et al (1990)

Crosstimbers: Savanna Grassland, 13.8 percent as Rolling Plains: Mixed-grass Prairie, 3.2 percent as High Plains: Floodplain Juniper Shrubland, and 2.6 percent as High Plains: Riparian Herbaceous Vegetation. The remaining 10 percent consists of Crosstimbers: Post Oak Woodlands, Crosstimbers: Oak/Hardwood Slope Forest, Rolling Plains: Breaks Deciduous Shrubland, Edward Plateau: Live Oak Motte and Woodland, Edward Plateau: Oak – Hardwood Motte and Woodland, Edward Plateau: Savanna Grassland, High Plains: Hardwood – Live Oak Forest, High Plains: Hardwood – Juniper Forest, High Plains: Hardwood Forest, High Plains: Floodplain Deciduous Shrubland, High Plains: Herbaceous Vegetation, High Plains: Riparian Live Oak Forest, High Plains: Riparian Hardwood Forest, High Plains: Riparian Juniper Shrubland, High Plains: Riparian Deciduous Shrubland, Native Invasive: Deciduous Woodland, Barren, Urban High Intensity, and Urban Low Intensity vegetation cover types (TPWD, 2020b).

Native Invasive: Mesquite Shrubland. Honey mesquite is often the dominant species of this broadly defined type, but other common species include lotebush (*Ziziphus obtusifolia*), huisache (*Acacia farnesiana*), sugar hackberry (*Celtis laevigata*), Ashe juniper (*Juniperus ashei*), agarito (*Mahonia trifoliolata*), winged elm (*Ulmus alata*), sumacs (*Rhus* spp.), brasil (*Condalia hookeri*), Texas persimmon (*Diospyros texana*), and Engelmann pricklypear (*Opuntia engelmannii*). Trees such as plateau live oak (*Quercus fusiformis*), coastal live oak (*Quercus virginiana*), or post oak (*Quercus stellata*) may form a sparse canopy. Prairie broomweed (*Amphiachyris dracunculoides*), Texas wintergrass, and tobosagrass (*Pleuraphis mutica*) are common herbaceous species. The type is mapped on soils that are classically considered to have supported grasslands or open shrublands in pre-European settlement times.

The Row Crops vegetation type includes all cropland where fields are fallow for some portion of the year. Some fields may rotate into and out of cultivation frequently, and year-round cover crops and tame hay fields are generally mapped as grassland.

The Crosstimbers: Savanna Grassland is a primarily herbaceous vegetation type, representing the graminoid dominated component of the savanna as it occurs within this system. Woody canopy represents less than 25 percent cover. Historically, little bluestem likely dominated these grasslands, but current composition may be largely determined by land use history and grazing pressure. In the east, where precipitation is greater, tallgrass species such as big bluestem and Indiangrass may be important components, where in the drier west, shortgrass species such as buffalograss become more conspicuous. Other graminoid species that may be present include Texas wintergrass, fringeleaf paspalum (*Paspalum setaceum*), tall dropseed (*Sporobolus compositus*), sideoats grama, hairy grama (*Bouteloua hirsuta*), Texas grama (*Bouteloua rigidiseta*), silver bluestem (*Bothriochloa laguroides* ssp. *torreyana*), and

threeawn (*Aristida* spp.). Non-native species such as bermudagrass (*Cynodon dactylon*), Japanese brome (*Bromus arvensis*), cheatgrass (*Bromus tectorum*), and King Ranch bluestem (*Bothriochloa ischaemum* var. *songarica*) are often significant components.

The Rolling Plains: Mixed-grass Prairie is a grassland dominated by species such as little bluestem, Texas wintergrass, sideoats grama, and silver bluestem. This type typically occupies loam, clay loams, or sandy loams. Honey mesquite is often an important woody component. Dry sites to the west often contain short grasses such as tobosagrass, purple threeawn (*Aristida purpurea*), and buffalograss together with honey mesquite and succulents such as Engelmann pricklypear and Arkansas yucca (*Yucca arkansana*). Wetter sites to the east may contain mid-grasses such as little bluestem, sideoats grama, Texas wintergrass, and tall grasses such as Indiangrass and big bluestem in locally well-watered areas.

The High Plains: Floodplain Juniper Shrubland tends to occupy broad valley bottoms with deep alluvial deposits. This type contains shrubland on floodplains dominated by Ashe juniper or redberry juniper (*Juniperus pinchotii*). Additional shrubland species include honey mesquite, black willow (*Salix nigra*), and saltcedar (*Tamarix* spp.).

The High Plains: Riparian Herbaceous Vegetation occurs along headwater streams and over upland soils that have developed over a variety of bedrock types. Herbaceous species commonly encountered include tobosagrass, Texas wintergrass, silver bluestem, and little bluestem.

3.6.3 Waters of the U.S., Including Wetlands

Waters of the U.S. include, but are not limited to, territorial seas, lakes, rivers, streams, oceans, bays, ponds, and other special aquatic features, including wetlands. The USACE regulates waters of the U.S., including wetlands, under Section 404 of the CWA. The USACE and EPA jointly define wetlands as those areas that are inundated or saturated by surface or ground water at a frequency and duration sufficient to support, and that under normal circumstances do support, a prevalence of vegetation typically adapted for life in saturated soil conditions. Wetlands generally include bogs, seeps, marshes, swamps, forested bottomland wetlands, and other similar areas (40 CFR 230.3[t]). Wetlands are defined in a broad sense as transitional areas (ecotones) between terrestrial and aquatic systems where the water table is usually at or near the ground surface, or where shallow water covers the land (Cowardin *et al.*, 1979).

The USFWS NWI maps encompassing the Study Area indicate the presence of wetland and open-water habitat features within the Study Area. Features in the Study Area are classified as palustrine and riverine. Palustrine systems include vegetated, freshwater wetlands and small (less than 20 acres), nonvegetated freshwater wetlands that are both shallow (deepest point less than 6.6 ft. at low water) and lack an active

wave-formed or bedrock shoreline (Cowardin et al., 1979). Within the Study Area are mapped freshwater emergent wetlands, freshwater forested/shrub wetlands, and freshwater ponds. Riverine systems include all wetlands and deepwater habitats contained within a channel, except wetlands dominated by trees, shrubs, persistent emergents, emergent mosses, or lichens, and habitats with water containing ocean-derived salts exceeding 0.5 percent (Cowardin et al., 1979).

Hydric and aquatic habitats may be considered regulatory wetlands by the USACE. Construction activities resulting in the discharge of dredged or fill materials within waters of the U.S. are subject to the regulations and restrictions outlined in Section 404 of the CWA and may require coordination with the USACE to ensure compliance.

3.7 Fish and Wildlife

3.7.1 Fish and Wildlife Habitats and Species

Blair (1950) delineated seven biotic provinces within Texas. As shown on Figure 3-3, Eastland County occurs within two Biotic Provinces: the Kansan and the Texan. The Kansan Biotic Province in Texas extends south and east from the Oklahoma and New Mexico borders, eventually transitioning to the Chihuahuan, Balconian, and Texan Biotic Provinces. The Kansan includes three distinct biotic districts, the Mixed-grass Plains, Short-grass Plains, and Mesquite Plains Districts. The Study Area lies within the Short-grass Plains District. Within the Short-grass Plains District, buffalograss is the principal vegetational constituent and is the most important plant association. Various species of grama grasses are also important to this area (Blair, 1950). Characteristic faunal species of the area are discussed below. The extensive agricultural development in the area has significantly reduced native grassland habitats. Wildlife species that occur include species that have historically occurred in the area, as well as others that are particularly adapted to this agricultural environment.

Aquatic habitats within the Study Area are minimal and include unnamed streams, wetlands, and ponds. Aquatic vegetation is limited by the ephemeral nature of these features.

3.7.2 Fish

Fish species are likely constrained in the Study Area due to the limited number of permanent waterbodies. Species that may occur in streams or ponds in the region include the American gizzard shad (*Dorosoma cepedianum*), common carp (*Cyprinus carpio*), black bullhead (*Ameiurus melas*), green sunfish (*Lepomis cyanellus*), orangespotted sunfish (*Lepomis humilis*), bluegill (*Lepomis macrochirus*), white crappie

Path: \\data\data\Projects\ESP\ONE STAR TRANSMISSION\Roadrunner\345kV\Geospatial\DataFiles\ArcDocs\RX2RS_Figure_3_3_Biotic_Provinces_Map_VR2.mxd gacox 6/16/2020
COPYRIGHT © 2020 BURNS & McDONNELL ENGINEERING COMPANY, INC.

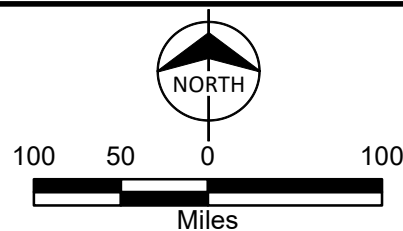

Figure 3-3
Location of Eastland County
in Relation to the
Biotic Provinces of Texas
Reata Station to
Roadrunner Crossing Wind
345 kV Transmission Line

(*Pomoxis annularis*), channel catfish (*Ictalurus punctatus*), flathead catfish (*Pylodictis olivaris*), and largemouth bass (*Micropterus salmoides*) (Thomas et al., 2007).

3.7.3 Amphibians and Reptiles

A representative list of amphibian and reptile species of potential occurrence in the Study Area is included as Table 3-1.

Table 3-1: Representative List of Reptile and Amphibian Species of Potential Occurrence^a in the Study Area

Common Name ^b	Scientific Name ^b
Frogs and Toads	
American bullfrog	<i>Lithobates catesbeianus</i>
Blanchard’s cricket frog	<i>Acris blanchardi</i>
Couch’s spadefoot	<i>Scaphiopus couchii</i>
Eastern Chihuahuan green toad	<i>Anaxyrus debilis debilis</i>
Rocky Mountain toad	<i>Anaxyrus woodhousii woodhousii</i>
Texas toad	<i>Anaxyrus speciosus</i>
Lizards	
Texas greater earless lizard	<i>Cophosaurus texanus texanus</i>
Eastern collared lizard	<i>Crotaphytus collaris</i>
Eastern six-lined racerunner	<i>Aspidoscelis sexlineata sexlineata</i>
Prairie lizard	<i>Sceloporus consobrinus</i>
Texas spiny lizard	<i>Sceloporus olivaceus</i>
Texas spotted whiptail	<i>Aspidoscelis gularis gularis</i>
Snakes	
Broad-banded copperhead	<i>Agkistrodon laticinctus</i>
Bullsnake	<i>Pituophis catenifer sayi</i>
Checkered gartersnake	<i>Thamnophis marcianus</i>
Chihuahuan nightsnake	<i>Hypsiglena jani</i>
Diamond-backed watersnake	<i>Nerodia rhombifer</i>
Eastern hog-nosed snake	<i>Heterodon platirhinos</i>
Eastern yellow-bellied racer	<i>Coluber constrictor flaviventris</i>
Great Plains ratsnake	<i>Pantherophis emoryi</i>
Long-nosed snake	<i>Rhinocheilus lecontei</i>
Plain-bellied watersnake	<i>Nerodia erythrogaster</i>
Variable groundsnake	<i>Sonora semiannulata semiannulata</i>
Western coachwhip	<i>Coluber flagellum testaceus</i>
Western diamond-backed rattlesnake	<i>Crotalus atrox</i>

Common Name ^b	Scientific Name ^b
Western ratsnake	<i>Pantherophis obsoletus</i>
Turtles	
Plains box turtle	<i>Terrapene ornata ornata</i>
Red-eared slider	<i>Trachemys scripta elegans</i>
Yellow mud turtle	<i>Kinosternon flavescens</i>

(a) According to Werler and Dixon (2000) and Dixon (2013)

(b) Nomenclature follows Crother et al. (2017)

3.7.4 Birds

Avian species of potential occurrence in the Study Area include many year-round residents, migrants/summer residents, and migrants/winter residents. A representative list of bird species of potential occurrence in the Study Area is included as Table 3-2.

Table 3-2: Representative List of Avian Species of Potential Occurrence^a in the Study Area

Common Name	Scientific Name ^b	Likely Seasonal Occurrence ^{a, c}
American avocet	<i>Recurvirostra americana</i>	M
American coot	<i>Fulica americana</i>	R
American crow	<i>Corvus brachyrhynchos</i>	R
American robin	<i>Turdus migratorius</i>	M, WR
American wigeon	<i>Anas americana</i>	M, WR
Ash-throated flycatcher	<i>Myiarchus cinerascens</i>	M, SR
Barn swallow	<i>Hirundo rustica</i>	M, SR
Bewick's wren	<i>Thryomanes bewickii</i>	R
Black-chinned hummingbird	<i>Archilochus alexandri</i>	M, SR
Black-crested titmouse	<i>Baeolophus atricristatus</i>	R
Blue jay	<i>Cyanocitta cristata</i>	R
Brewer's blackbird	<i>Euphagus cyanocephalus</i>	M, WR
Brown-headed cowbird	<i>Molothrus ater</i>	R
Carolina chickadee	<i>Poecile carolinensis</i>	R
Cattle egret	<i>Bubulcus ibis</i>	M, SR
Cedar waxwing	<i>Bombycilla cedrorum</i>	M, WR
Common nighthawk	<i>Chordeiles minor</i>	M, SR
Cooper's hawk	<i>Accipiter cooperii</i>	M, WR
Dunlin	<i>Calidris alpina</i>	M
Eastern phoebe	<i>Sayornis phoebe</i>	R
European starling	<i>Sturnus vulgaris</i>	R
Franklin's gull	<i>Leucophaeus pipixcan</i>	M

Common Name	Scientific Name ^b	Likely Seasonal Occurrence ^{a, c}
Golden-fronted woodpecker	<i>Melanerpes aurifrons</i>	R
Great blue heron	<i>Ardea herodias</i>	R
Great horned owl	<i>Bubo virginianus</i>	R
Greater roadrunner	<i>Geococcyx californianus</i>	R
Greater yellowlegs	<i>Tringa melanoleuca</i>	M, WR
Great-tailed grackle	<i>Quiscalus mexicanus</i>	R
Green heron	<i>Butorides virescens</i>	M, SR
Green-winged teal	<i>Anas crecca</i>	M, WR
Horned lark	<i>Eremophila alpestris</i>	R
House finch	<i>Haemorhous mexicanus</i>	R
House sparrow	<i>Passer domesticus</i>	R
Killdeer	<i>Charadrius vociferus</i>	R
Ladder-backed woodpecker	<i>Dryobates scalaris</i>	R
Lark bunting	<i>Calamospiza melanocorys</i>	M, WR
Least sandpiper	<i>Calidris minutilla</i>	M, WR
Loggerhead shrike	<i>Lanius ludovicianus</i>	R
Mississippi kite	<i>Ictinia mississippiensis</i>	M, SR
Mourning dove	<i>Zenaida macroura</i>	R
Northern bobwhite	<i>Colinus virginianus</i>	R
Northern cardinal	<i>Cardinalis cardinalis</i>	R
Northern flicker	<i>Colaptes auratus</i>	M, WR
Northern harrier	<i>Circus cyaneus</i>	M, WR
Northern mockingbird	<i>Mimus polyglottos</i>	R
Northern pintail	<i>Anas acuta</i>	M, WR
Northern shoveler	<i>Anas clypeata</i>	M, WR
Painted bunting	<i>Passerina ciris</i>	M, SR
Pied-billed grebe	<i>Podilymbus podiceps</i>	M, WR
Redhead	<i>Aythya americana</i>	M, WR
Red-tailed hawk	<i>Buteo jamaicensis</i>	R
Red-winged blackbird	<i>Agelaius phoeniceus</i>	M, R
Rock pigeon	<i>Columba livia</i>	R
Ruby-crowned kinglet	<i>Regulus calendula</i>	M, WR
Rufous-crowned sparrow	<i>Aimophila ruficeps</i>	R
Sandhill crane	<i>Antigone canadensis</i>	M, WR
Savannah sparrow	<i>Passerculus sandwichensis</i>	M, WR
Scissor-tailed flycatcher	<i>Tyrannus forficatus</i>	M, SR

Common Name	Scientific Name ^b	Likely Seasonal Occurrence ^{a, c}
Swainson's hawk	<i>Buteo swainsoni</i>	M, SR
Turkey vulture	<i>Cathartes aura</i>	M, SR
Verdin	<i>Auriparus flaviceps</i>	R
Vesper sparrow	<i>Pooecetes gramineus</i>	M, WR
Western kingbird	<i>Tyrannus verticalis</i>	M, SR
Western meadowlark	<i>Sturnella neglecta</i>	R
White-eyed vireo	<i>Vireo griseus</i>	M, SR
White-winged dove	<i>Zenaida asiatica</i>	R
Wild turkey	<i>Meleagris gallopavo</i>	R
Yellow-billed cuckoo	<i>Coccyzus americanus</i>	M, SR
Yellow-rumped warbler	<i>Setophaga coronata</i>	M, WR

(a) According to Lockwood and Freeman (2014).

(b) Nomenclature follows Chesser et al. (2019)

(c) R – Resident: Occurring regularly in the same general area throughout the year-implies breeding

SR – Summer Resident: Implies breeding but may include nonbreeders

WR – Winter Resident: Occurring during winter season

M – Migrant: Occurs as a transient passing through the area either in spring or fall or both

3.7.5 Mammals

A representative list of mammals that may occur in the Study Area is included as Table 3-3.

Table 3-3: Representative List of Mammalian Species of Potential Occurrence^a in the Study Area

Common Name ^b	Scientific Name ^b
Xenarthrans	
Nine-banded armadillo	<i>Dasypus novemcinctus</i>
Chiroptera	
Brazilian free-tailed bat	<i>Tadarida brasiliensis</i>
Cave myotis	<i>Myotis velifer</i>
Townsend's big-eared bat	<i>Corynorhinus townsendii</i>
Western pipistrelle	<i>Pipistrellus hesperus</i>
Carnivores	
American badger	<i>Taxidea taxus</i>
Bobcat	<i>Lynx rufus</i>
Common gray fox	<i>Urocyon cinereoargenteus</i>
Coyote	<i>Canis latrans</i>
Northern raccoon	<i>Procyon lotor</i>
Striped skunk	<i>Mephitis mephitis</i>
Artiodactyls	
White-tailed deer	<i>Odocoileus virginianus</i>
Rodents	
Deer mouse	<i>Peromyscus maniculatus</i>
Eastern white-throated woodrat	<i>Neotoma leucodon</i>

Common Name ^b	Scientific Name ^b
Fulvous harvest mouse	<i>Reithrodontomys fulvescens</i>
Hispid cotton rat	<i>Sigmodon hispidus</i>
Hispid pocket mouse	<i>Chaetodipus hispidus</i>
Merriam’s pocket mouse	<i>Perognathus merriami</i>
Mexican ground squirrel	<i>Spermophilus mexicanus</i>
Northern grasshopper mouse	<i>Onychomys leucogaster</i>
Ord’s kangaroo rat	<i>Dipodomys ordii</i>
Plains pocket gopher	<i>Geomys bursarius</i>
Southern plains woodrat	<i>Neotoma micropus</i>
Spotted ground squirrel	<i>Spermophilus spilosoma</i>
Texas mouse	<i>Peromyscus attwateri</i>
White-footed mouse	<i>Peromyscus leucopus</i>
Lagomorphs	
Black-tailed jackrabbit	<i>Lepus californicus</i>
Desert cottontail	<i>Sylvilagus audubonii</i>
Eastern cottontail	<i>Sylvilagus floridanus</i>

(a) According to Schmidly and Bradley (2016)

(b) Nomenclature follows Bradley et al. (2014)

3.8 Recreationally and Commercially Important Species

A species is considered important if one or more of the following criteria applies:

- a. The species is recreationally or commercially valuable
- b. The species is endangered or threatened
- c. The species affects the well-being of some important species within criterion (a) or (b)
- d. The species is critical to the structure and function of the ecological system
- e. The species is a biological indicator

Wildlife resources within the Study Area provide human benefits resulting from both consumptive and nonconsumptive uses. Nonconsumptive uses include observing and photographing wildlife, bird watching, and other similar activities. These uses, although difficult to quantify, deserve consideration in the evaluation of the wildlife resources of the Study Area. Consumptive uses, such as fishing, hunting, and trapping, are more easily quantifiable. Consumptive and nonconsumptive uses of wildlife are often enjoyed contemporaneously and are generally compatible. Many species occurring in the Study Area provide consumptive uses, and all provide the potential for nonconsumptive benefits.

The white-tailed deer (*Odocoileus virginianus*) is the most economically important big game mammal in Texas (Schmidly, 2004). The TPWD divides the State into ecological regions for deer management. Eastland County falls within the Cross Timbers and Prairies Ecological Region. During the 2017–2018

hunting season, an estimated 119,510 white-tailed deer were harvested within this ecological region. Callahan County falls within the Rolling Plains Ecological Region. During the 2017–2018 hunting season, an estimated 73,253 white-tailed deer (Eastern Rolling Plains) and 3,416 mule deer were harvested within this ecological region (Purvis, 2018a).

The Cross Timbers and Prairies and the Rolling Plains Ecological Regions also provide habitat for a variety of economically and recreationally important upland game birds, including the mourning dove (*Zenaida macroura*), white-winged dove (*Zenaida asiatica*), northern bobwhite (*Colinus virginianus*), scaled quail (*Callipepla squamata*), and wild turkey (*Meleagris gallopavo*). During the 2017–2018 hunting season, an estimated 553,613 mourning dove, 158,821 white-winged dove, 1,742 northern bobwhite, and 8,759 wild turkey were harvested within the Cross Timbers and Prairies Ecological Region, and an estimated 729,980 mourning dove, 141,747 white-winged dove, 202,342 northern bobwhite, 8,625 scaled quail, and 6,009 wild turkey were harvested within the Rolling Plains Ecological Region (Purvis, 2018b).

3.9 Endangered and Threatened Species

An endangered species is one that is in danger of extinction throughout all or a significant portion of its natural range, while a threatened species is one likely to become endangered within the foreseeable future throughout all or a significant portion of its range.

3.9.1 Endangered and Threatened Plant Species

Available information from the USFWS (2020a), TPWD (2020c), and TPWD's NDD (TPWD, 2020d) was reviewed to identify endangered or threatened plant species of potential occurrence within the Study Area. Currently, 31 plant species are listed by the USFWS as endangered or threatened species in Texas (USFWS, 2020b). However, no Federal or State-listed plants have been recorded from Eastland County or Callahan County (USFWS, 2020a; TPWD, 2020c). No sensitive plant communities have been specifically identified by either the USFWS or TPWD as occurring within the Study Area (USFWS, 2020a; TPWD, 2020d).

3.9.2 Federally Listed Fish and Wildlife Species

The USFWS (2020a) and TPWD (2020c) county lists of endangered and threatened species indicate that nine federally listed endangered, threatened, or proposed for Federal listing fish and wildlife species may occur in Eastland and Callahan Counties (Table 3-4). Protection under the ESA can also include protection of habitat designated as critical habitat for supporting a listed species. It should be noted that inclusion in this table does not necessarily mean that a species is known to occur in the Study Area, but

only acknowledges the potential for its occurrence, based on historic records, known ranges, and presence of potential habitat. Only those species that USFWS lists as endangered or threatened have Federal protection under the ESA. Most avian species are protected under the MBTA and bald and golden eagles are protected under the BGEPA.

Table 3-4: Federally Listed Fish and Wildlife Species for Eastland and Callahan Counties^a

Common Name	Scientific Name ^b	Status	Potential for Occurrence in the Study Area
		USFWS	
Birds			
Golden-cheeked warbler	<i>Setophaga chrysoparia</i>	Endangered	Not likely ^c
Interior least tern ^d	<i>Sternula antillarum athalassos</i>	Endangered	Not likely ^c
Whooping crane	<i>Grus americana</i>	Endangered	Not likely ^c
Piping plover ^d	<i>Charadrius melodus</i>	Threatened	Not likely ^c
Red knot ^d	<i>Calidris canutus rufa</i>	Threatened	Not likely ^c
Eastern black rail ^e	<i>Laterallus jamaicensis ssp. jamaicensis</i>	Proposed threatened	Not likely ^c
Fishes			
Sharpnose shiner	<i>Notropis oxyrhynchus</i>	Endangered	Does not occur
Smalleye shiner	<i>Notropis buccula</i>	Endangered	Does not occur
Mollusks			
Texas fawnsfoot	<i>Truncilla macrodon</i>	Candidate	Does not occur

(a) According to USFWS (2020a) and TPWD (2020c, 2020d)

(b) Nomenclature follows Crother et al. (2017), Chesser et al. (2019), USFWS (2020a), and TPWD (2020c)

(c) Only expected to occur as a migrant, transient, or rare vagrant within the Study Area

(d) Only needs to be considered for wind energy projects

(e) Not listed by USFWS (2020a) as occurring in Eastland County or Callahan County

The USFWS considers five of the taxa in Table 3-4 as endangered, two as threatened, one as proposed threatened, and one as a candidate for listing. They are the endangered golden-cheeked warbler (*Setophaga chrysoparia*), interior least tern (*Sternula antillarum athalassos*), whooping crane (*Grus americana*), sharpnose shiner (*Notropis oxyrhynchus*), and smalleye shiner (*Notropis buccula*); the threatened piping plover (*Charadrius melodus*) and red knot (*Calidris canutus rufa*); the proposed threatened eastern black rail (*Laterallus jamaicensis ssp. jamaicensis*), and the candidate for listing Texas fawnsfoot (*Truncilla macrodon*).

3.9.2.1 Golden-cheeked Warbler

The golden-cheeked warbler is currently a rare to locally common summer resident in about 28 central Texas counties, which comprise the species' entire breeding range. The species is a habitat specialist,

occurring only in oak-juniper woodlands that contain a dense deciduous canopy and mature Ashe junipers (*Juniperus ashei*), Texas live oak (*Quercus fusiformis*), Texas red oak (*Quercus buckleyi*), post oak (*Quercus stellata*), cedar elm (*Ulmus crassifolia*), hackberries (*Celtis* spp.), Texas ash (*Fraxinus texensis*), and occasionally, escarpment black cherry (*Prunus serotina*) and American sycamore (*Plantanus occidentalis*) (Ladd and Gass, 1999). According to TPWD (2020d) and eBird (2020), no documented records of the golden-cheeked warbler occur within the Study Area. This species may traverse the Study Area during migration or as a vagrant; however, it is highly unlikely that the species regularly occurs within the Study Area due to a lack of suitable habitat.

3.9.2.2 Interior Least Tern

In Texas, the interior least tern historically nested on sandbars of the Colorado River, Red River, and Rio Grande. Currently, its winter range includes the entire Texas Gulf Coast. The interior least tern's preferred nesting habitat is unvegetated, frequently flooded sand flats, salt flats, sand and gravel bars, and sand, shell, and gravel beaches (Thompson et al., 1997; Campbell, 2003). The species would only be expected as a rare migrant within the Study Area (Lockwood and Freeman, 2014). No documented records exist from the Study Area (TPWD, 2020d; eBird, 2020), and the species is not expected to occur within the Study Area due to the general absence of suitable habitat.

3.9.2.3 Whooping Crane

The whooping crane is North America's tallest wading bird. Only four wild populations of whooping crane exist. The only self-sustaining and largest wild population is the Aransas-Wood Buffalo population (AWBP). The AWBP breeds in Wood Buffalo National Park in northern Canada and migrates annually to wintering grounds in the Aransas National Wildlife Refuge (NWR) and adjacent areas of the central Texas Coast in Aransas, Calhoun, and Refugio Counties (USFWS, 1995, 2009a; Lewis, 1995; Canadian Wildlife Service and USFWS, 2007). Individuals have wintered a considerable distance from these three counties, including as far away as the Panhandle and south to Willacy County (Lockwood and Freeman, 2014). The three smaller wild populations include the nonmigratory Florida and Louisiana populations and one population that migrates between Wisconsin and Florida. These are not self-sustaining populations, and each is designated as an "experimental population, non-essential."

During migration, whooping cranes travel during daylight hours and stop over at wetlands, fallow cropland, and pastures to roost and feed. Whooping cranes have an unpredictable pattern of stopover use and may not use the same stopover sites annually. They spend a short period of time at any one location ranging from overnight to several days in inclement weather. Federal and State efforts to record information on whooping cranes sighted in migration began in 1975 and have continued to the present

Path: \\data\srv\data\Projects\ESP\ONE STAR TRANSMISSION\Roadrunner 345kV\Geospatial\DataFiles\ArcDocs\RX2RS_Figure_3_4_WhoopingCraneFigure.mxd gacox 6/16/2020
COPYRIGHT © 2020 BURNS & MCDONNELL ENGINEERING COMPANY, INC.

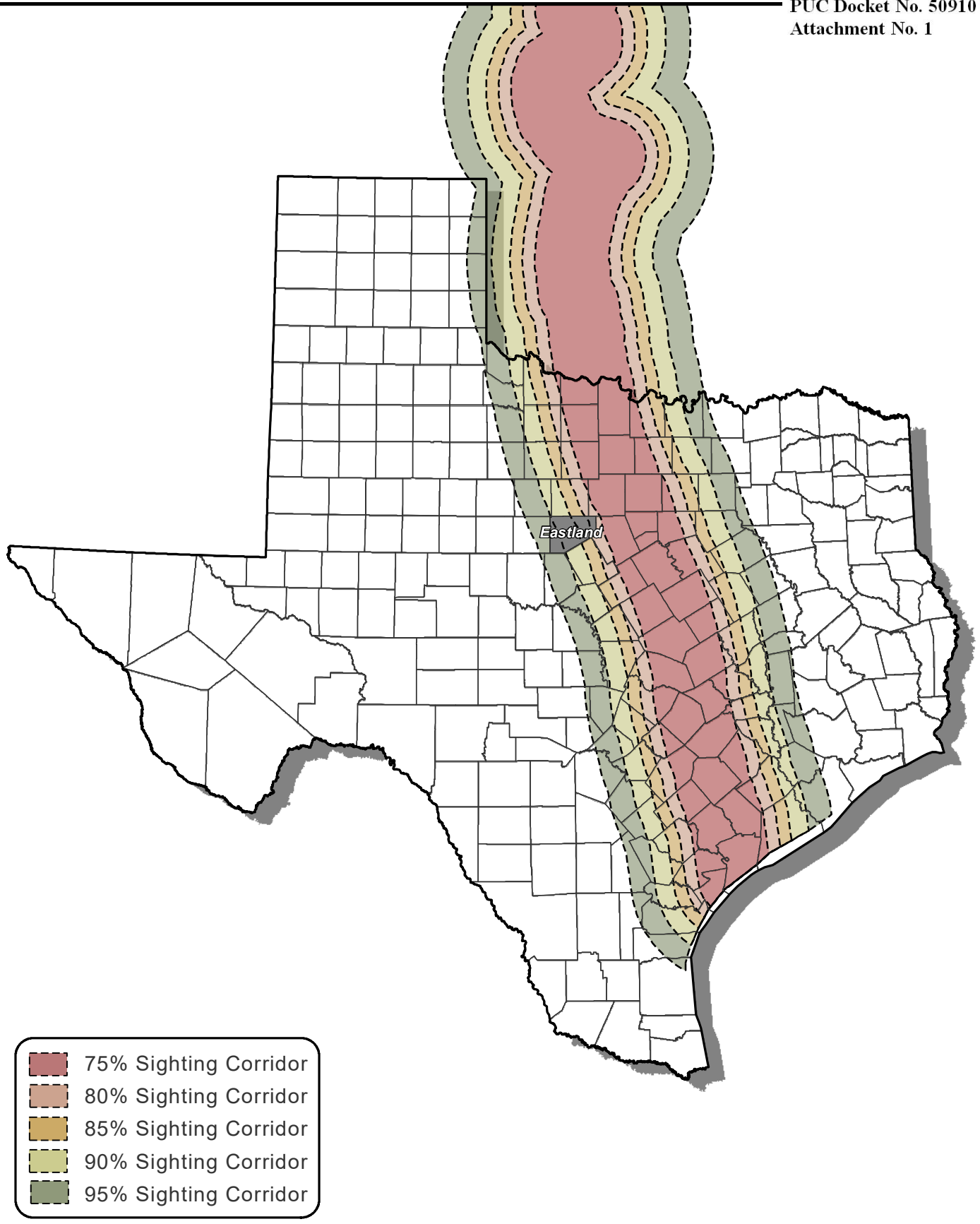

- 75% Sighting Corridor
- 80% Sighting Corridor
- 85% Sighting Corridor
- 90% Sighting Corridor
- 95% Sighting Corridor

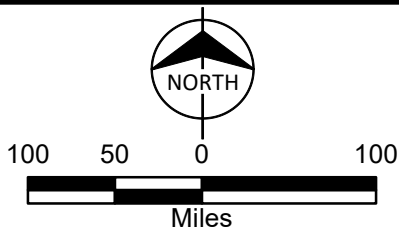

Figure 3-4
Location of Eastland County
in Relation to the
Central U.S. Whooping Crane Flyway
Reata Station to
Roadrunner Crossing Wind
345 kV Transmission Line

day through the Cooperative Whooping Crane Tracking Project (CWCTP) in the U.S. and Canada (USFWS, 2009a; Tacha et al., 2010). The database incorporates records for the period of 1943 through 2009. As of the fall of 2009, 140 confirmed sightings of migrating whooping cranes occurred in Texas, from the fall of 1965 to the fall of 2009 (USFWS, 2009b). None of these recorded occurrences are within Eastland County; however, one record exists from Callahan County, approximately 20 miles west of the Study Area (USFWS, 2009b). As shown on Figure 3-4, the Study Area lies within the zone that encompasses 95 percent of known sightings. TPWD (2020d) does not show any documented records of occurrence within the Study Area, and it is extremely unlikely that this species would occur in the Study Area.

3.9.2.4 Piping Plover

The piping plover is a small shorebird that inhabits sandy beaches and alkali flats (Cornell Lab of Ornithology, 2020). Approximately 35 percent of the known global population of the piping plover winters along the Texas Gulf Coast, where the plovers spend 60 to 70 percent of the year (Campbell, 2003). The piping plover population that winters in Texas breeds on the northern Great Plains and around the Great Lakes.

The species is an uncommon to locally common winter resident along the coastal areas of Texas and can linger through the summer on very rare occasions. Piping plovers are not often observed during migration at inland locations, and most appear to pass east of the Balcones Escarpment (Lockwood and Freeman, 2014). No documented records of the piping plover exist from the Study Area (TPWD, 2020d; eBird, 2020), and it is extremely unlikely that this species would occur in the Study Area.

3.9.2.5 Red Knot

The red knot is a medium-sized, stocky, short-necked sandpiper with a rather short, straight bill. The *rufa* subspecies, one of three subspecies occurring in North America, has one of the longest migration distances known, travelling between its breeding grounds in the central Canadian Arctic to wintering areas that are primarily in South America (USFWS, 2011). During migration and winter in Texas, red knots may be found feeding in small groups, on sandy, shell-lined beaches, and to a lesser degree, on flats of bays and lagoons (Oberholser, 1974). It is an uncommon migrant along the coast, especially the Upper Texas coast, and very rare to casual inland, primarily in the eastern half of the State (Lockwood and Freeman, 2014). No documented records of the red knot exist from the Study Area (TPWD, 2020d; eBird, 2020), and it is extremely unlikely that this species would occur in the Study Area.

3.9.2.6 Eastern Black Rail

The black rail, a small secretive bird, is broadly distributed living in salt and freshwater marshes in portions of the United States, Central America, and South America. The habitat for the species can be tidally or nontidally influenced and can range in salinity from salt to brackish to fresh (USFWS, 2020c). The Eastern black rail, a subspecies, is a rare migrant in the eastern third of the State, with migrants rarely being detected, and are rare to locally uncommon residents on the upper and central coasts (Lockwood and Freeman, 2014). This species may traverse the Study Area during migration or as a vagrant; however, it is very unlikely that the species regularly occurs within the Study Area due to a lack of suitable habitat.

3.9.2.7 Sharpnose shiner

The sharpnose shiner is a ray-finned fish belonging to the family Cyprinidae (carps and minnows), is straw-colored with silvery sides, and grows up to 3.74 inches in length (Texas State University, 2018). The sharpnose shiner is currently restricted to the upper Brazos River and its major tributaries in north-central Texas, which represents a greater than 70 percent range reduction. The species historically occurred along most of the Brazos River and parts of its major tributaries. The sharpnose shiner also naturally occurred in the Colorado River and in the Wichita River. Sharpnose shiners are limited to the main channel and certain tributaries of the upper Brazos River basin where they are blocked from moving downstream by Possum Kingdom Lake. With only one isolated population remaining, this species is unable to disperse downstream, and is in danger of extinction from only one adverse event, such as a lack of river flow for two consecutive years (USFWS, 2014, 2015). No documented records of the sharpnose shiner exist in the Study Area (TPWD, 2020d) and the species does not occur in the Study Area due to its currently restricted range and lack of suitable habitat.

3.9.2.8 Smalleye shiner

The smalleye shiner, a freshwater minnow, historically occurred along most of the Brazos River and parts of its major tributaries (USFWS, 2015). It is currently restricted to the contiguous river segments of the upper Brazos River basin in north-central Texas. No documented records of the smalleye shiner exist in the Study Area (TPWD, 2020d) and the species does not occur in the Study Area due to its currently restricted range and lack of suitable habitat.

3.9.2.9 Texas Fawnsfoot

The Texas fawnsfoot, a freshwater mussel endemic to central Texas, historically inhabited the Colorado, Trinity, and Brazos drainages; however, its habitat remains largely unknown, possibly preferring rivers and larger streams, and it is intolerant of impoundment (TPWD, 2009). This species is now known from only five populations, and only the lower Colorado, San Saba, and Brazos River populations are likely to

be stable and recruiting (USFWS, 2016). TPWD (2020d) does not show any documented records of the Texas fawnsfoot within the Study Area and the species would not be expected within the Study Area due to the general absence of appropriate habitat.

3.9.3 Critical Habitat

The USFWS, in Section 3(5)(A) of the ESA, defines critical habitat as:

“(i) the specific areas within the geographical area occupied by the species, at the time that it is listed in accordance with the ESA, on which are found those physical or biological features (I) essential to the conservation of the species and (II) which may require special management considerations or protection; and (ii) specific areas outside the geographical area occupied by a species at the time it is listed, upon a determination by the Secretary of the Interior that such areas are essential for the conservation of the species.” (USFWS, 1973)

No critical habitat has been designated in the Study Area for any species included under the ESA.

3.9.4 State-Listed Fish and Wildlife Species

State-listed species receive protection under State laws, such as Chapters 67, 68, and 88 of the TPWD Code, and sections 65.171–65.184 and 69.01–69.14 of Title 31 of the Texas Administrative Code. Three species are protected at the State level and designated as threatened within Eastland and Callahan Counties (Table 3-5) (TPWD, 2020c). They are the white-faced ibis (*Plegadis chihi*), zone-tailed hawk (*Buteo albonotatus*), and Texas horned lizard (*Phrynosoma cornutum*).

Table 3-5: State-Listed Fish and Wildlife Species for Eastland and Callahan Counties^a

Common Name	Scientific Name ^b	Status	Potential for Occurrence in the Study Area
		TPWD	
Birds			
White-faced ibis	<i>Plegadis chihi</i>	Threatened	Not likely ^c
Zone-tailed hawk	<i>Buteo albonotatus</i>	Threatened	Not likely ^c
Reptiles			
Texas horned lizard	<i>Phrynosoma cornutum</i>	Threatened	Likely

(a) According to USFWS (2020a) and TPWD (2020c, 2020d).

(b) Nomenclature follows Crother et al. (2017), Chesser et al. (2019), USFWS (2020a), and TPWD (2020c).

(c) Only expected to occur as a migrant, transient, or rare vagrant within the Study Area.

3.9.4.1 White-faced Ibis

The white-faced ibis is a medium-sized wading bird that inhabits freshwater marshes, sloughs, and irrigated rice fields, but also frequents brackish and saltwater habitats (Ryder and Manry, 1994). White-faced ibis are permanent residents along the Texas Gulf Coast with nesting records existing from areas

away from the coast as far north as the Panhandle (Lockwood and Freeman, 2014). The species is a rare to uncommon migrant throughout the State and occasionally occurs as a post-breeding visitor north and west of its typical range. According to TPWD (2020d) and eBird (2020), no documented records of the white-faced ibis occur within the Study Area. White-faced ibis may occur in the Study Area as a rare vagrant; however, it is unlikely that this species would reside or nest within the Study Area and is unlikely that the species regularly occurs within the Study Area due to a lack of suitable habitat.

3.9.4.2 Zone-tailed Hawk

The zone-tailed hawk is an uncommon and local summer resident in the mountains of the central Trans-Pecos, east through the southern Edwards Plateau regions of Texas and is a rare migrant and winter resident in the Lower Rio Grande Valley (Lockwood and Freeman, 2014). Zone-tailed hawks may occur in the Study Area as rare vagrants; however, it is unlikely that this species would reside or nest within the Study Area.

3.9.4.3 Texas Horned Lizard

The Texas horned lizard occurs throughout the western half of the State in a variety of habitats but prefers arid and semi-arid environments in sandy loam or loamy sand soils that support patchy bunch-grasses, cacti, yucca, and various shrubs (Henke and Fair, 1998). While the species has almost vanished from the eastern half of the State over the past 30 years, it still maintains relatively stable numbers in west Texas. Although TPWD (2020d) shows no documented records within the Study Area for this species, the Texas horned lizard may occur in small numbers in suitable habitat within the Study Area.

3.10 Human Resources

3.10.1 Community Values and Community Resources

The term “community values” is included as a factor for consideration of transmission line certification under PURA § 37.056(c)(4). Although the term is not formally defined in the statute or PUC rules, the PUC and PUC Staff have recognized a working definition as “a shared appreciation of an area or other natural resource by a national, regional, or local community” in several CCN proceedings.

Burns & McDonnell evaluated the proposed Project for community resources that may be important to a particular community as a whole, such as parks or recreational areas, historical and archeological sites, or scenic vistas within the Study Area. Additionally, Burns & McDonnell mailed consultation letters to Federal, State, and local officials (Appendix A) to identify and collect information regarding community

values and community resources, among other things. Input received was used in the evaluation of the proposed Project. Community values and community resources are discussed in the following sections.

3.10.2 Land Use

The Study Area is primarily located in northwestern Eastland County, approximately six miles west-northwest of the city of Cisco, which serves as the county seat. A narrow portion of the Study Area extends into the easternmost portion of Callahan County. Eastland County has a total land area of approximately 952 square miles, and the July 2019 total population was estimated at 18,360 (U.S. Census Bureau, 2020). No incorporated city nor unincorporated community is located within the Study Area. The landscape consists of level to rolling mesquite-covered plains, dissected by a few eroded breaks and streambeds.

The Study Area is located in State Planning Region No. 7, represented by the West Central Texas Council of Governments (WCTCOG), which covers a 17,789 square-mile region and includes 19 contiguous counties: Brown, Callahan, Coleman, Comanche, Eastland, Fisher, Haskell, Jones, Kent, Knox, Mitchell, Nolan, Runnels, Scurry, Shackelford, Stephens, Stonewall, Taylor, and Throckmorton. The WCTCOG, which was established in 1966 and contains approximately 330,814 people within its service area, is a voluntary association that promotes area-wide planning and cooperation among local governments to assist with the health, safety, and general welfare of its citizens; plan for future development; make efficient and economical use of public funds; eliminate waste from duplication; and assist all member governments in solving both current and long-range problems (Texas Association of Regional Councils [TARC], 2020). The Study Area is located predominately within the Cisco Independent School District (ISD), with the northwestern portion of the Study Area located within the Baird ISD jurisdiction. No school campus or other ISD facility is located within the Study Area (Texas Education Agency [TEA], 2020).

The Study Area is located within a rural portion of the county and is dominated by agricultural fields, rangeland, and shrubland. Some erosional breaks associated with unnamed tributaries of Battle Creek exist in the southern portion of the Study Area, as well as its northwestern corner. Otherwise, the Study Area is generally flat to undulating in topography and elevation, which ranges from a high of 1,616 ft. above msl near the Study Area's southern boundary, to a low of 1,459 ft. msl in the Study Area's northwestern corner.

The total land area of the Study Area is approximately 2,240 acres (3.5 square miles) and according to USDA National Agricultural Statistics Service geospatial data includes approximately 1,350 acres of

rangeland (60.6 percent), approximately 780 acres of cropland (34.9 percent), approximately 60 acres of developed land (2.7 percent), approximately 35 acres of forest (1.6 percent), and approximately 6 acres of open water (0.3 percent) (USDA, 2019a).

Oil production has had some presence in Eastland County since 1917, when the Texas and Pacific Coal and Oil Company discovered potential near Ranger, east of the Study Area. An oil boom ensued, producing 22 million barrels in 1919 and lasting into the 1920s, and spurring the extension of two railroads into Eastland County (Leffler, 2019). According to the RRC records (2020b), numerous oil or gas wells are located within the Study Area; most are currently identified as plugged wells and “dry holes”, but some active oil wells and a number of permitted locations exist. No oil or gas development or exploration was observed within the Study Area during field reconnaissance.

3.10.3 Recreation

A review of the Texas Outdoor Recreation Plan (TORP); Federal, State, and local maps; an internet search; and field reconnaissance identified no Federal, State, county, or municipal park, forest/grassland, wildlife refuge, wildlife management area, or preserve within the Study Area (TPWD, 2020e; National Park Service [NPS], 2020; National Conservation Easement Database [NCED], 2020; USGS, 2020; USACE, 2020). Recreational activities such as hunting may occur on private properties within the Study Area, but these properties are not open to the public. According to the TORP, this region of Texas (West Central Texas, Region 7) is more popular with hunters than any other region in Texas (TPWD, 1984).

3.10.4 Agriculture

According to the most recent published USDA 2017 Census of Agriculture, the total market value of agricultural products in Eastland County was \$23,519,000, which is a 16 percent decrease from the county’s 2012 total market value of \$27,875,000. For comparison, the total market value of agricultural products sold within Texas dropped 2 percent, from approximately \$25.4 billion to over \$24.9 billion during the same period (USDA, 2012, 2019b).

The number of farms in Eastland County increased from 1,174 in 2012 to 1,198 in 2017 (an increase of 2 percent). However, the total land in farms within Eastland County decreased from 503,633 acres to 489,773 acres (a decrease of 3 percent) during that period (USDA, 2012, 2019b).

In terms of value of sales by commodity group, the most valuable agricultural products within Eastland County in 2017 included (1) cattle and calves (\$16,881,000); (2) other crops and hay (\$2,712,000); and (3) fruits, tree nuts, and berries (\$1,046,000) (USDA, 2019b).

A slight majority of the Study Area is devoted to rangeland for cattle, in the form of shrubland and open pasture. According to the USDA, approximately 60.5 percent (1,350 acres) of the Study Area consists of rangeland. In terms of crop production, the predominant crop by far is winter wheat; approximately 33 percent (745 acres) of the Study Area has been planted with this crop. Sorghum, oats, and cotton each comprise less than 1 percent of the Study Area's land cover. The remainder of the Study Area is classified as developed land, forest, or open water (USDA, 2019a). No center-pivot or other above-ground irrigation systems were observed within the Study Area.

3.10.5 Transportation and Aviation

The major transportation features located within the rural Study Area include unpaved county roads, and include: CR 107, CR 125, CR 126, CR 128, CR 314, and CR 748. CR 126 runs through the majority of the Study Area, from its southern boundary and roughly bisecting the Study Area heading northwards to its intersection with CR 125 (TxDOT, 2020a). The remainder of the transportation network within the Study Area consists of privately-maintained ranch roads and driveways.

A review of the Dallas-Fort Worth Sectional Aeronautical Chart (FAA, 2020), the TxDOT Airport Directory (TxDOT, 2020b), aerial photography, USGS maps, field reconnaissance, AirNav (2020), and other internet sources identified no FAA-registered airport, no private landing strip, and no heliport within or near the Study Area.

3.10.6 Communication Towers

A search of the Federal Communications Commission (FCC) website, online cell tower search engines, and field reconnaissance identified no commercial AM or FM radio tower, cellular tower, or any other electronic communication tower within the Study Area (FCC, 2020; AntennaSearch, 2020; Cell Reception, 2020).

3.10.7 Utilities

Existing electric facilities within the Study Area include Lone Star Transmission's West Shackelford to Sam Switch 345 kV Transmission Line and a network of Comanche Electric Cooperative distribution lines along the county roads.

3.10.8 Aesthetic Values

Aesthetics is included as a factor for consideration in the evaluation of transmission facilities in PURA § 37.056(c)(4). The term aesthetics refers to the subjective perception of natural beauty in the landscape, and this section of the document attempts to define and measure the Study Area's scenic qualities.

Consideration of the visual environment includes a determination of aesthetic values where the major potential effect of the Project on the resource is considered aesthetic, or where the location of a transmission line could affect the scenic enjoyment of a recreation area.

The aesthetic analysis considers potential visual impacts to the public. Areas visible from major roads and highways, or publicly owned or accessible lands (*e.g.*, parks or privately owned recreation areas open to the public) were analyzed. Several factors are taken into consideration when attempting to define the potential impact to a scenic resource that would result from the construction of the proposed transmission line. Among these are:

- topographical variation (*e.g.*, hills, valleys)
- prominence of water in the landscape
- vegetation variety (*e.g.*, forests, pasture)
- diversity of scenic elements
- degree of human development or alteration, and
- overall uniqueness of the scenic environment compared to the larger region.

The THC operates the Texas Heritage Trails Program, a Statewide heritage tourism program based on 10 scenic driving trails originally created by TxDOT. This program operates throughout 10 regions of Texas and enables people to learn about, and be surrounded by, local customs, traditions, history, and culture of the different regions. The Study Area is located within the Texas Forts Region, which contains the Texas Forts Trail. This trail region stretches across 29 counties in Central West Texas and highlights the lakes, historic towns, parks and preserves, as well as cultural and recreational opportunities of the region, including a Spanish presidio and eight historic frontier forts. Although the Study Area is located within the Texas Forts Region, none of the recommended cities, sites, or points of interest are located within the Study Area (THC, 2020).

In 1998, TxDOT published a list of some of the best “Scenic Overlooks and Rest Areas” in Texas, each of which presented particularly strong aesthetic views or settings (TxDOT, 1998). A review of this list identified no highlighted scenic overlook or rest area within the Study Area. No other outstanding aesthetic resources, designated scenic views, or unique visual elements were identified from the literature review or from ground reconnaissance of the Study Area.

Based on these criteria, the Study Area exhibits a moderate degree of aesthetic quality for the region. The majority of the Study Area is in agricultural use, with plowed fields and rangeland dominated by mesquite and a few stock ponds. While the eastern portion of Eastland County features varied topography, with

rolling plains, eroded breaks, and lakes, the Study Area is categorized by mostly flat terrain with little woodland and no significant permanent waterbodies. Only a few isolated residential structures are located within the Study Area, but the landscape has experienced a high degree of alteration due to transportation corridors, existing electric transmission lines, and agricultural practices.

3.11 Cultural Resources

As shown on Figure 3-5, Eastland County occurs in the Texas Plains Planning Region as delineated by the THC (Mercado-Allinger et al., 1996). Geographically, the Study Area is on the boundary of the Cross Timbers and Central Great Plains (Griffith et al., 2007). Human occupation of the Texas Plains is divided chronologically into five cultural periods that span over 11,500 years and include Paleoindian, Archaic, Ceramic, Protohistoric, and Historic (Perttula, 2004; Johnson and Holliday, 2004). These divisions are marked by shifts in subsistence strategies and technological innovations visible in the archeological record and through documented oral and written histories. The following sections present an overview of the region's cultural history and the associated archeological and historic resources that could potentially be located within the Study Area.

3.11.1 Paleoindian

Archeological evidence suggests that people first lived within the Texas Plains around 12,000 years ago. This occupational phase is referred to as the Paleoindian period and extends from the end of the Pleistocene Epoch until the early Holocene. The phase can be subdivided further into Clovis (11,500 to 11,000 B.C.), Folsom (10,800 to 10,300 B.C.), and Late Paleoindian cultures, including Plainview (ca. 10,000 B.C.) and Firstview (ca. 8,600 B.C.) (Johnson and Holliday, 2004).

For decades, scholars commonly believed Paleoindian peoples traveled in highly mobile hunting and gathering bands, living a nomadic lifestyle, and exploiting, by choice, a limited number of resources. However, more recent archeological research at the Aubrey and Lubbock Lake sites outside of Dallas and Lubbock, respectively, has revealed evidence of a more diversified subsistence base that included small and medium mammals in addition to the more traditional large mammals and megafauna. The Folsom culture is well represented at Lubbock Lake, and archeological investigations focusing on this period have provided evidence of increased reliance on extinct species of bison for subsistence, as well as shifting lithic technologies (Carlson, 2005).

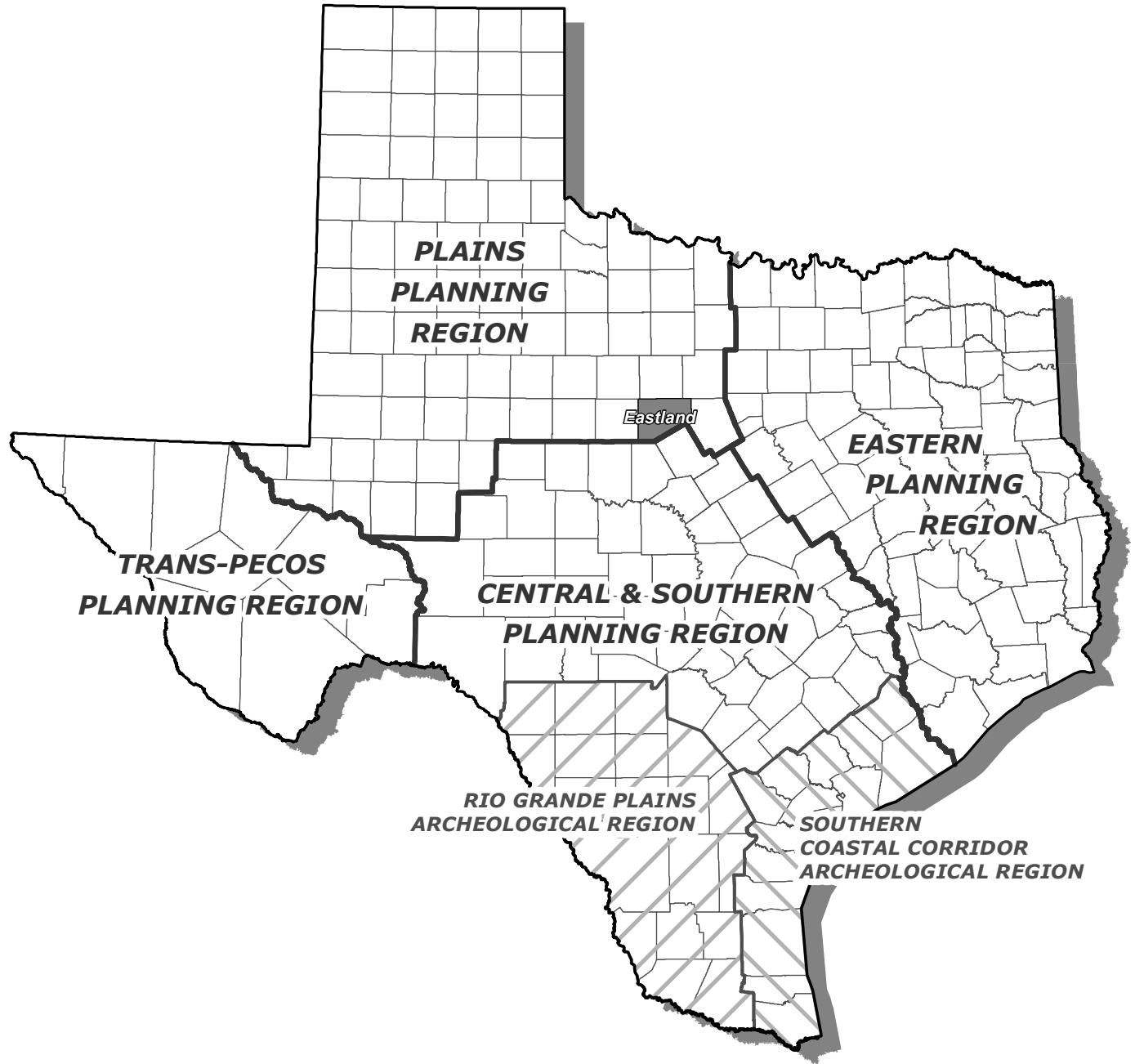

Path: \\data\data\Projects\ESP\ONE STAR TRANSMISSION\Roadrunner\345kV\Geospatial\DataFiles\ArcDocs\RX2RS_Figure_3_5_Cultural_Planning_Regions_Map.mxd gacox 6/16/2020
COPYRIGHT © 2020 BURNS & MCDONNELL ENGINEERING COMPANY, INC.

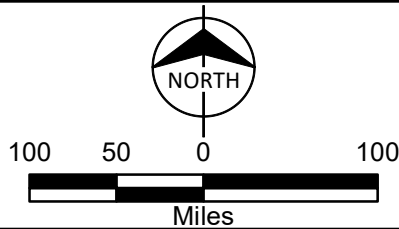

Figure 3-5
Location of Eastland County
in Relation to the Cultural Resources
Planning Regions of Texas
Reata Station to
Roadrunner Crossing Wind
345 kV Transmission Line

Following the decline of the Folsom cultural phase, around 10,300 B.C., archeologists have identified a series of varied cultural groups distinguished according to a wide range of projectile point styles.

Common Late Paleoindian points include Plainview and Firstview, but other points, some of which have contracting stems, were also developed. It appears that people relied upon a diverse diet including plants and small game as well as the continued exploitation of bison. Evidence of this subsistence strategy has been documented at the Lake Theo site in Briscoe County and at Lubbock Lake (Harrison and Killen, 1978; Johnson and Holliday, 2004).

3.11.2 Archaic

The start of the Archaic period (8000 to 2000 B.C.) coincides roughly with the start of the Hypsithermal climatic episode that resulted in an overall warmer and drier climate (Hofman, 1989; Kay, 1998).

Consequently, a sudden extinction of megafauna populations forced peoples to exploit faunal resources in bottomland and forested areas (Johnson and Holliday, 2004). Changes in overall subsistence practices during the Archaic appear to have led to accompanying technological shifts. Stemmed (expanding and contracting) and notched (corner and basal) projectile points began to be used, and hafting technologies changed. The lithic toolkit was also expanded to include groundstone tools for the first time, such as manos, metates, and pestles.

During the Middle and Late Archaic period, a further expansion of the lithic toolkit appears to have occurred. Varieties of stemmed, corner-notched, and shallow side-notched projectile points became increasingly popular during this period, as did scrapers, perforators, drills, knives, grooved axes, bannerstones, and plummets. The Archaic culture relied heavily upon bison as an important food source, along with other smaller game. An increase in groundstone tool use, including manos and pestles, also occurred, a phenomenon that is believed to reflect further inclusion of seeds and nuts in people's diets (Blackmar and Hofman, 2006).

3.11.3 Ceramic

The Early Ceramic period (2000 to 1000 B.C.) appears to have been a transitional time for peoples living in the Texas Plains. Several new innovations, including pottery and the bow and arrow, were introduced. Additionally, limited evidence of horticulture and the presence of storage features suggest people continued a foraging lifestyle while moving toward a more sedentary existence (Johnson and Holliday, 2004). Typical cultural markers for this period include thick, conoidal-shaped ceramic vessels and corner- and basally notched arrow points.

Diagnostic artifacts of the Early Ceramic include corner-notched and stemmed arrow points and brownware ceramics (Boyd, 2004). Excavations at the Kent and Sam Wahl sites in the panhandle suggest a continued foraging lifestyle with seasonal habitation sites and hunting and plant-processing campsites. Excavated features include burials, hearths, pits, burned-rock features, and rectangular to oval pit houses.

During the Middle Ceramic period of the Texas Plains, people appear to have been primarily semi-sedentary horticulturists with semi-permanent to permanent residences. Artifact assemblages from this period include cord-marked pottery, diamond-shaped beveled knives, triangular projectile points, distal end scrapers, drills, bison-bone digging sticks, and scapula hoes for practicing agriculture. It was during this period that the first widespread permanent villages appear to have been established, typically on ridges and terraces near perennial streams and arable land (Brosowske, 2005). Subsistence strategies included the harvesting of cultigens such as corn, squash, and beans, as well as hunting game and collecting edible wild plants. Bison continued to play a major role in people's diets (Brooks, 2004).

3.11.4 Protohistoric

In general, scholars believe Apachean groups dominated the Texas Plains during the period of European contact, particularly the Lipan Apache with later incursions by the Comanche, Cheyenne, Arapaho, and Kiowa (Hofman, 1989). Evidence from archeological excavations suggests people were primarily nomadic bison hunters with some sedentary camp settlements and limited horticulture. However, Eastland County was too heavily wooded for bison (Leffler, 2019). The Tierra Blanca site in Deaf Smith County contains some of the best evidence for protohistoric life on the Texas Plains. Features include tipi rings, stone foundations, open hearths, and semi-subterranean, slab-lined circular structures (Hofman, 1989).

3.11.5 Historic

The first Euroamerican settlers arrived in what is now Eastland County in the 1850s. In 1858, Eastland County was formed from land formerly assigned to Bosque, Coryell, and Travis Counties. The county is named for Williams Moby Eastland, a soldier in the Texas Revolution and the only officer of the Mier Expedition who was executed by order of Santa Anna during the Black Bean Episode. Eastland was designated the county seat in 1875 (Leffler, 2019).

The 1860 census counted only 99 people in Eastland county. Settlers grew small plots of corn, beans, and sweet potatoes and raised sheep and cattle. The county remained sparsely settled until the 1870s due to frequent conflicts with Kiowa and Comanche. By 1880 4,855 people were living in Eastland County. Corn, cotton, and cattle dominated the economy. By 1881 the Texas and Pacific and the Texas Central railroads reached Eastland County, and a new town, Cisco, was organized at the intersection of the two

railroads. The railroads encouraged settlement and helped to open the area to commercial farming and diversified the economy. By 1890 the county boasted dry goods stores, livery stables, saddleries, boardinghouses, drugstores, real estate agencies, and a nursery (Leffler, 2019).

The population reached 17,971 by 1900. Much of the county's growth during the late nineteenth and early twentieth centuries is attributed to a cotton boom during this period. Cotton production dropped off abruptly between 1910 and 1916 as a result of a boll weevil infestation. In 1917, just as the cotton boom was ending, oil was discovered in the county. Thousands of investors and jobseekers flocked to the county. By 1920, the census reported 58,508 residents in Eastland County because of the oil boom. The Eastland Wichita Falls and Gulf Railroad and Wichita Falls, Ranger and Fort Worth Railroad were built during the boom. The oil boom faltered after oil production tapered off in 1922, but the agricultural sector began to recover at about that same time, with a brief resurgence in cotton and increase in cattle production.

Many residents of Eastland County suffered during the Great Depression. The population of the county decreased from 34,156 in 1930 to 30,345 in 1940. Cotton production almost ceased entirely during the Depression. The mechanization of agriculture combined with other factors contributed to a steady decline in the population of the county from 23,942 in 1950, to 19,526 in 1960, and to 18,092 in 1970. The population has remained at about this level and oil, ranching, and agriculture remain the most important sectors of the economy, although peanuts, sorghum, wheat, pecans, and peaches have replaced cotton (Leffler, 2019).

3.11.6 Literature and Records Review

Burns & McDonnell conducted an examination of the Texas Archeological Sites Atlas (TASA) to identify previously conducted cultural resources investigations and previously recorded archeological sites and other designated nonarcheological historic resources, including NRHP-listed properties and districts, State Antiquities Landmarks (SALs), historic-age cemeteries, and Official Texas Historical Markers (OTHMs), including Recorded Texas Historic Landmarks (RTHLs), within the Study Area.

Only one previous cultural resources investigation has been conducted within the Study Area. Survey #8500023658 crosses the southern end of the Study Area. The survey was conducted in 2012 by Horizon Environmental Services in support of the Lone Star Competitive Renewable Energy Zone (CREZ) Transmission Line. One archeological site was identified within the current Study Area during this survey. Archeological site 41EA26 is the remnants of a historic-age farmstead, including a surface artifact scatter, brick well, and concrete foundation. The site was determined ineligible for NRHP inclusion in

2012. Additionally, one historic-age cemetery is recorded within the Study Area on the TASA. Dothan Cemetery is a designate Historic Texas Cemetery located on CR 126 near the southern extent of the Study Area. The historic marker at the cemetery says:

The Texas and Pacific Railway built the Delmar depot near here in 1880 before rail activity shifted to Red Gap (later Cisco). A new community named Dothan formed and gained a post office in 1902. Jim and Manirval (Short) Dunaway, who settled here in 1886, donated land for a community cemetery. The first burial was their great-grandson, Carroll Leo Dunaway, in 1905. Dothan included a school and stores and by 1915 reported a population of fifty. The school closed in 1940. Family and friends have always maintained the cemetery, which features granite, limestone and fieldstone grave markers, a wire perimeter fence, and at least 22 Veterans' graves. The Dothan Cemetery Association formed in 1989 to preserve this historic vestige of a rural community.

Dothan Cemetery contains more than 164 interments and is still in use today (Find a Grave, 2020). No additional cultural resources or other previous cultural resources investigations were identified within the Study Area.

4.0 ENVIRONMENTAL IMPACTS OF THE PROJECT

The potential and anticipated impacts to natural, human, and cultural resources resulting from the proposed Project are discussed below by subject area.

4.1 Impact on Natural Resources

4.1.1 Impact on Physiography and Geology

Construction of the proposed transmission line will have no significant effect on the physiographic or geologic features and resources of the area. Erection of the structures would require the removal and minor disturbance of small amounts of near-surface materials but would have no measurable impact on the geologic resources or features along the Consensus Route. The Project will have no significant impact on mineral resources in the Study Area.

4.1.2 Impact on Soils

The construction and operation of transmission lines normally create very few long-term adverse impacts on soils. Transmission lines are not normally considered to cause a conversion of farmland because the site can still be used in this capacity after construction. The major potential impact upon soils from any transmission line construction would be erosion and soil compaction. The potential for soil erosion is generally greatest during the initial clearing of the ROW; however, erosion control measures during the clearing and construction process will be employed. Where existing land cover includes woody vegetation within the ROW, much of this vegetation will be removed to provide adequate space for construction activities and to minimize corridor maintenance and operational concerns. In these areas, only the leaf litter and a small amount of herbaceous vegetation would remain, and both would be disturbed by the necessary movement of heavy equipment.

Construction of the transmission line would require minimal amounts of clearing in areas that have already been cleared for crops, pastures, and existing road ROW. The most important factor in controlling soil erosion associated with construction activity is to revegetate areas that have potential erosion problems immediately following construction. Natural succession would revegetate most of the ROW. Impacts from soil erosion caused by construction activity would be minimized due to the implementation of BMPs designed in the SWPPP. Areas where construction activity has occurred will be restored and revegetated in accordance with the SWPPP and the PUC final order.

Prime farmland soils, as defined by the NRCS, are soils that are best suited for producing food, feed, forage, or fiber crops. The USDA recognizes the importance and vulnerability of prime farmlands

throughout the nation and encourages the wise use and conservation of these soils where possible. According to the NRCS mapping tool, the Project would likely cross prime farmland soils. In addition to construction-related impacts described above, the major impact of the Project on soils would be the physical occupation of small areas by the actual support structures. However, most of the ROW would be available for agricultural use once construction of the transmission line is completed.

4.1.3 Impact on Water Resources

4.1.3.1 Surface Water

Construction and operation of the transmission line would have minimal adverse impact on the surface water resources of the area. The Consensus Route would span all streams. Potential impacts from any major construction project include short-term disturbances resulting from construction activities, which would result primarily from increased siltation from erosion and decreased water quality from accidental spillage of petroleum and other chemical products. Additionally, activities such as clearing of vegetation may temporarily increase local stormwater runoff volumes and sediment loading. Potential impacts would be avoided whenever possible by spanning surface waters, diverting construction traffic around water resources via existing roads, and eliminating unnecessary clearing of vegetation.

Although impacts would be avoided to the extent practicable, some unavoidable impacts could occur. Reducing vegetation removal around surface water features and minimizing ground disturbance would minimize these impacts. The use of erosion control measures, such as silt fencing and selective clearing, and BMPs regarding the use of chemicals, would also minimize potential impacts. As such, impacts occurring from construction of the proposed transmission line would be short term and minor because of the relatively small area that would be disturbed at any one time, the short duration of the construction activities, the preservation of vegetation adjacent to surface water features where practicable, and the implementation of BMPs designed in the SWPPP to control runoff from construction areas. Contractors will also make efforts during construction for proper control and handling of any petroleum or other chemical products.

The measurements of the various criteria used in the environmental analysis of the Consensus Route for this Project are tabulated in Table 6-1 in Section 6.0 of this report. The Consensus Route crosses four streams and parallels streams within 100 ft. for approximately 65 ft. of its length; however, it does not cross open water (such as ponds).

Generally, surface water resources do not present a major constraint to transmission line construction, unless navigable river crossings or impacts to wetlands occur that would warrant USACE permitting, or

areas that would require extensive woodland clearing near streams, which would present potential erosion control problems. However, navigable river crossings, extensive contiguous wetland systems, and areas requiring extensive woodland clearing near streams do not exist along the Consensus Route. After the Project is approved, a survey may be performed to determine if USACE permitting is warranted.

4.1.3.2 Floodplains

The Consensus Route crosses approximately 340 ft. of 100-year floodplains. Proposed construction could result in locating some transmission line structures within floodplains. These structures would be designed and constructed so as to minimize impendence of the flow of any waterway or create any hazard during flooding. Construction activities within floodplains would be limited to the project ROW, and significant efforts would be made to keep structures from being in obvious flood channels. Some scour could occur around structures if flood-flow depths and velocities become great enough. Careful siting of structures should eliminate the possibility of significant scour. The Project should have no significant impact on the function of floodplains, nor adversely affect adjacent property or downstream property.

4.1.3.3 Groundwater

No adverse impacts to groundwater are expected to occur from the construction and operation of the proposed transmission line. The amount of recharge area that would be disturbed by construction is minimal when compared to the total amount of recharge area available for the aquifer systems in the region. Additionally, if accidental spillage of fuel, lubricants, or other petroleum products occurred from normal operation of heavy equipment during construction activities, it would be unlikely to result in any groundwater contamination. Any accidental spills would be promptly handled in accordance with State and Federal regulations. Contractors will take necessary precautions to avoid and minimize the occurrence of such spills.

4.1.4 Impact on the Ecosystem

4.1.4.1 Vegetation

Impacts to vegetation resulting from the construction and operation of transmission lines are primarily associated with the removal of existing woody vegetation within the ROW and conversion to herbaceous vegetation. The amount of vegetation cleared from the transmission line ROW would be dependent upon the type of vegetation present and whether the ROW will be completely new or involve widening existing ROW. For example, the greatest amount of vegetation clearing generally occurs in wooded areas, whereas cropland and grassland usually require little to no removal of vegetation.

Cropland and rangeland dominate the Study Area, and very little clearing of trees will be necessary for construction. The linear extent of plant communities crossed by the Consensus Route was determined using digital aerial imagery, and the length across potential wetlands was estimated by referencing USFWS NWI maps (see Table 6-1 in Section 6.0). Vegetation community types within the ROW along the Consensus Route were verified in the field. Regarding woody vegetation communities, the Consensus Route crosses approximately 1,476 ft. of brushland/shrubland that would require removal.

Construction of the facility within the ROW would be performed to minimize adverse impacts to vegetation. Lone Star will minimize damage to local vegetation and retain native ground cover wherever practicable. Clearing will occur only where necessary to provide access and working space and to protect conductors. Where necessary, soil conservation practices will be undertaken to protect local vegetation and ensure successful revegetation for areas disturbed during construction.

The Consensus Route crosses four streams and according to USFWS NWI maps, it crosses approximately 95 ft. of mapped areas that potentially support wetlands. Potential wetlands will be spanned by the transmission line and, therefore, no waters of the U.S. will be impacted. Precautions would be taken throughout the construction process to avoid and minimize impacts to wetlands. Placement of approved BMPs for construction and minimization of erosion in disturbed areas would help dissipate the flow of runoff. Placement of silt fences or hay-bale dikes near disturbed areas would also help prevent siltation

4.1.4.2 Aquatic Resources

Impacts to aquatic ecosystems from transmission line construction are generally minor. Aquatic features along the Consensus Route, such as streams, can generally be spanned. The implementation of sedimentation controls, as prescribed in the Project-specific SWPPP, during construction will help to minimize erosion and sedimentation into area streams. Potential impacts include physical habitat loss or modification, increased runoff, erosion and sedimentation, turbidity, and spillage of petroleum or other chemical products. However, all these tend to be short-term effects and will vary with the intensity and timing of the construction along the Consensus Route. Contractors will make efforts during construction for proper control and handling of any petroleum or other chemical products.

Physical habitat loss or modification could result whenever access road crossings intercept a drainage system, through sedimentation due to erosion, increased suspended solids loading, or accidental petroleum spills directly into a creek or other aquatic feature crossed by the Consensus Route. Erosion results in siltation and increased suspended solids entering streams or wetlands, which in turn may negatively affect many aquatic organisms at many trophic levels. Since aquatic features of the area

typically exhibit relatively high turbidities during and following runoff events, small increases in suspended solids during the construction phase are unlikely to have any discernible adverse impact.

Potential impacts to aquatic resources will be minor. Typically, the main considerations regarding potential impacts to aquatic systems include the length across wetlands and open water, and length of ROW paralleling (within 100 ft.) streams. The Consensus Route crosses four streams, parallels approximately 65 ft. of streams within 100 ft., and crosses approximately 95 ft. of mapped potential wetlands; however, it does not cross any open water such as ponds.

4.1.4.3 Wildlife

The transmission line (both structures and wires) could present a hazard to flying birds, particularly migrants. Collision may result in disorientation, crippling, or mortality (New York Power Authority, 2005). Mortality is directly related to an increase in structure height; number of guy wires, conductors, and ground wires; and use of solid or pulsating red lights (Erickson et al., 2005). Birds are known to be attracted to non-flashing red lights and less attracted to flashing lights (FCC, 2015). In addition to lighting concerns, collision hazards are greatest near habitat “magnets” (e.g., wetlands, open water, edges, and riparian zones) and during the fall when flight altitudes of dense migrating flocks are lower in association with cold air masses, fog, and inclement weather. However, the Consensus Route does not cross any ponds or open water. The greatest danger of mortality exists during periods of low ceiling, poor visibility, and drizzle when birds are flying low, perhaps commencing or terminating a flight, and when they may have difficulty seeing obstructions (Electric Power Research Institute, 1993). Most migrant species known to occur in the Study Area, including passerines, should be minimally affected during migration, since their normal flying altitudes are much greater than the heights of the proposed transmission structures (Willard, 1978; Gauthreaux, 1978).

Transmission line structures will be designed in compliance with the Avian Power Line Interaction Committee (APLIC) suggested practices, as defined in *Reducing Avian Collisions with Power Lines: The State of the Art in 2012* (APLIC, 2012). As such, the danger of electrocution to birds from this Project is anticipated to be insignificant. Some avian species may use transmission line structures or wires for perching and roosting locations; however, this is not the designed intent of those facilities. Additionally, edge-adapted species such as the blue jay (*Cyanocitta cristata*), some flycatchers, northern cardinal (*Cardinalis cardinalis*), northern bobwhite (*Colinus virginianus*), Cooper’s hawk (*Accipiter cooperii*), brown-headed cowbird (*Molothrus ater*), and northern mockingbird (*Mimus polyglottos*) may select the edge habitat created along the changed vegetation areas adjacent to the transmission ROW (Rochelle et al., 1999).

Any required clearing or other construction-related activities would directly or indirectly affect most animals that reside within or traverse the transmission line ROW. Heavy machinery may adversely affect smaller, low-mobility species, particularly amphibians, reptiles, and small mammals. If construction occurs during the breeding season (generally spring to fall), construction activities may adversely affect the young of some species if breeding is occurring in the immediate vicinity of the ROW. Heavy machinery may cause soil compaction, which may adversely affect fossorial animals (*i.e.*, those that live underground). Mobile species, such as birds and larger mammals, may avoid initial clearing and construction activities and move into adjacent areas outside the ROW. Wildlife in the immediate area may experience a slight loss of browse or forage material during construction; however, the prevalence of similar habitats in adjacent areas and vegetation succession in the ROW following construction would minimize the effects of these losses.

The increased noise and activity levels during construction could potentially disturb the daily activities (*e.g.*, breeding, foraging) of species inhabiting the areas adjacent to the ROW. Dust and gaseous emissions should have only minimal effects on wildlife. Although construction activities may disrupt the normal behavior of many wildlife species, little permanent damage to these populations should result. Periodic clearing along the ROW, while producing temporary negative impacts to wildlife, can improve the habitat for ecotonal or edge species through the increased production of small shrubs, perennial forbs, and grasses.

In general, the greatest potential impact to wildlife typically results from the loss and fragmentation of woodland and wetland habitats. Woodlands, particularly, are relatively static environments that require greater regenerative time compared with cropland or emergent wetlands. The Consensus Route, however, crosses very little woodland (approximately 620 ft. of bottomland/riparian woodland) and 1,476 ft. of brushland/shrubland. No waterbodies occur with the Consensus Route ROW and all streams will be spanned, with little or no resulting impact to wildlife.

In summary, the typical net impacts of transmission lines on wildlife are minor and include short-term effects resulting from physical disturbance during construction, as well as long-term effects resulting from habitat modification, fragmentation, or loss. These typical net minor impacts are also expected with this Project and the Consensus Route.

4.1.4.4 Recreationally and Commercially Important Species

Construction of the proposed Project is not expected to have significant impacts on terrestrial recreationally and commercially important species in the Study Area. Game species such as the white-

tailed deer, mourning dove, and bobwhite are very mobile and will leave the immediate vicinity during the initial construction phase. Wildlife in the immediate area may experience a temporary loss of browse or forage vegetation during construction; however, the prevalence of similar habitats in adjacent areas will minimize the effect of the loss. The proposed Project would have little or no impact on hunting and fishing within the Study Area, as the proposed construction timeframe would occur outside of the primary hunting seasons in the Study Area.

4.1.4.5 Endangered and Threatened Species

No endangered or threatened plant species have been recorded from Eastland or Callahan Counties; therefore, no listed plant species will be adversely affected by the proposed Project. According to USFWS (2020a) and TPWD (2020c), the only two Federal or State-listed endangered or threatened fish species of potential occurrence in the Study Area counties are the federally listed endangered sharpnose shiner and smalleye shiner. Both these species have very restricted ranges that lie outside the Study Area and would not occur within the Study Area. Additional aquatic species of potential occurrence in Eastland and Callahan Counties include the Texas fawnsfoot, a Federal candidate species. Due to the restricted range and lack of suitable habitat, it is not expected to occur within the Study Area. Additionally, any aquatic habitat is expected to be spanned to avoid impacts. Overall, the proposed transmission line Project should not adversely affect any endangered or threatened aquatic species.

According to TPWD (2020c), the only reptile species of potential occurrence in Eastland and Callahan Counties is the State-listed threatened Texas horned lizard. The Texas horned lizard may reside within the Study Area, and if this species is present along the Consensus Route, individuals could experience minor temporal disturbance during construction efforts.

Avian species protected under the ESA that may migrate through the Study Area, such as the golden-cheeked warbler, interior least tern, whooping crane, piping plover, red knot, and eastern black rail; the white-faced ibis and zone-tailed hawk (both State-listed as threatened); and other bird species that receive protection under provisions of the BGEPA and the MBTA, such as the bald eagle, may be affected by the presence of transmission lines. If these species occur in the Study Area following construction of the Project, they may be susceptible to wire strikes. Larger birds are more prone to transmission line collisions because their large wingspans and lack of maneuverability make avoiding obstacles more difficult (APLIC, 1994). However, the normal flying altitudes of most migrant species are greater than the heights of the proposed transmission structures (Gauthreaux, 1978; Willard, 1978). Additionally, the Project will be designed following APLIC suggested practices (APLIC, 2012), which will minimize the attractiveness of the structures for perching and nesting.

4.1.4.6 Critical habitat

No federally designated critical habitat for any endangered or threatened species is located in the Study Area. Therefore, the proposed Project will have no impact on critical habitat.

4.2 Impact on Human Resources

4.2.1 Impact on Community Values

Adverse effects upon community values are defined as aspects of the proposed Project that would significantly and negatively alter the use, enjoyment, or intrinsic value attached to an important area or resource by a community. This definition assumes that community concerns are identified with the location and specific characteristics of the proposed transmission line and do not include possible objections to electric transmission lines in general.

Impacts on community values can be classified into two areas: (1) direct effects, or those effects that would occur if the location and construction of a transmission line results in the removal or loss of public access to a valued resource; and (2) indirect effects, or those effects that would result from a loss in the enjoyment or use of a resource due to the characteristics (primarily aesthetic) of the proposed line, structures, or ROW. Impacts on community values, whether direct or indirect, can be more accurately gauged as they affect recreational areas or resources and the visual environment of an area (aesthetics). Impacts in these areas are discussed in detail in Sections 4.2.3 and 4.2.8 of this report, respectively.

4.2.2 Impact on Land Use

Land-use impacts from transmission line construction are determined by the amount of land (of varying use) displaced by the actual ROW and by the compatibility of electric transmission line ROW with adjacent land uses. During construction, temporary impacts to land uses within the ROW could occur due to the movement of workers and materials through the area. Construction noise and dust, as well as temporary disruption of traffic flow, may also temporarily affect residents in the area near the ROW. Coordination among contractors and landowners regarding access to the ROW and construction

4.2.2.1 Habitable Structures

Generally, one of the most important measures of potential land use impact is the number of habitable structures located within a specified distance of a route centerline. Habitable structures are defined by 16 TAC § 25.101(a)(3) as:

Structures normally inhabited by humans or intended to be inhabited by humans on a daily or regular basis. Habitable structures include, but are not limited to, single-family and multifamily

dwellings and related structures, mobile homes, apartment buildings, commercial structures, industrial structures, business structures, churches, hospitals, nursing homes, and schools (PUC, 2015).

Review of aerial imagery and field reconnaissance of the Study Area and the Consensus Route determined that no habitable structure is located within 500 ft. of the Consensus Route's centerline.

4.2.2.2 Utilizing/Paralleling Existing Transmission Line ROW

The least impact to land use generally results from building within existing transmission line ROW, followed by building parallel to existing transmission line ROW. Utilizing existing transmission line ROW of sufficient width usually eliminates the need for additional clearing. Furthermore, building parallel to existing transmission line ROW, when compared to establishing a new ROW corridor, can also minimize the amount of ROW to be cleared, which generally results in the least amount of impact to landowners, the environment, and the overall aesthetic quality of that area. In fact, the factors listed by 16 TAC § 25.101(b)(3)(B) to be considered in the selection of alternative routes include:

- Whether the routes parallel or utilize existing compatible ROW for electric facilities, including the use of vacant positions on existing multiple-circuit transmission lines
- Whether the routes parallel or utilize other existing compatible ROW, including roads, highways, railroads, or telephone utility ROW
- Whether the routes parallel property lines or other natural or cultural features

The Consensus Route does not utilize any existing transmission line ROW for this Project, nor does the Consensus Route parallel existing transmission line ROW.

4.2.2.3 Paralleling Other Existing Compatible ROW

Paralleling other existing compatible ROW (*e.g.*, roads, highways) is also generally considered to be a positive routing criterion, one that usually results in fewer impacts than establishing a new ROW corridor within an area and is included in the PUC's transmission line certification criteria. The Consensus Route parallels CR 126 for 11,746 ft., or approximately 97 percent of its total length.

4.2.2.4 Paralleling Property Lines

Another important land use criterion is the length of property lines paralleled. In the absence of existing ROW to follow, paralleling property or fence lines minimizes disruption to agricultural activities and creates less of a constraint to future development of a tract of land. The Consensus Route does not parallel any additional property lines that were measured as length parallel to other existing compatible ROW.

4.2.3 Impact on Recreation

Potential impacts to recreational land, which includes the disruption or preemption of recreational activities, would not occur from the proposed Project as no park or recreation area is crossed by the Consensus Route or located within 1,000 ft. of the Consensus Route.

4.2.4 Impact on Agriculture

Agricultural activities constitute a significant land use throughout the Study Area. Potential impacts to agricultural land uses include the disruption or preemption of farming activities. Disruption may include the time lost going around or backing up to structures to cultivate as much area as possible, and the general loss of efficiency compared to plowing or planting unimpeded in straight rows. Preemption of agricultural activities refers to the actual amount of land lost to production directly under the structures. Structures (and routes) located along field edges (*e.g.*, property lines, roads, drainage ditches) generally present fewer problems for farming operations than structures and routes located across open fields. Construction-related activities could slightly impact agricultural production, depending upon the timing of construction related to the local planting and harvesting schedule. Impacts to agricultural land uses can generally be ranked by degree of potential impact; forested land has the highest degree of impact, followed by cultivated cropland, with the least-potential impact occurring in areas where cultivation is not the primary use (pastureland/rangeland).

In this regard, the Consensus Route crosses approximately 2,815 ft. of pastureland/rangeland and approximately 5,835 ft. of cropland. Due to the relatively small area affected (beneath the structures), and the short duration of construction activities at any one location, such impacts should be temporary and minor. Since the ROW for this Project will not be fenced or otherwise separated from adjacent lands, no significant long-term displacement of farming or grazing activities will occur. Most existing agricultural land uses may be resumed following construction.

The Consensus Route does not cross any portions of cropland irrigated by center-pivot or other aboveground mechanical means.

4.2.5 Impact on Transportation and Aviation

Potential impacts to transportation could include temporary disruption of traffic and conflicts with proposed roadway or utility improvements and may include increased traffic during construction of the proposed Project. However, the Project would generate only minor construction traffic at any given time or location. This traffic would consist of construction employees' personal vehicles, truck traffic for material deliveries, trucks for structure foundation work, and mobile cranes for structure erection. Such

impacts, however, are usually temporary and short term. Road crossing permits and access permits will not be required from TxDOT prior to construction, as the Consensus Route does not cross a State-maintained roadway.

The proposed transmission line should have no significant effect on aviation operations within the Study Area. According to Federal Aviation Regulations (FAR), Part 77, notification of the construction of the proposed transmission line will be required if structure heights exceed the height of an imaginary surface extending outward and upward at a slope of 100 to 1 for a horizontal distance of 20,000 ft. from the nearest point of the nearest runway of a public or military airport having at least one runway longer than 3,200 ft. (FAA, 2011). For a public or military airport having a runway shorter than 3,200 ft., notification would be required if structure heights exceed the height of an imaginary surface extending at a slope of 50 to 1 for 10,000 ft. Notification is also required for structure heights exceeding the height of an imaginary surface extending outward and upward at a slope of 25 to 1 for a horizontal distance of 5,000 ft. from the nearest point of the nearest landing and takeoff area for heliports.

No FAA-registered airport is located within 20,000 ft., no private landing strip is located within 10,000 ft., and no helipad is located within 5,000 ft. of the Consensus Route. The proposed Project would have no effect on aviation operations in the Study Area.

4.2.6 Impact on Communication Towers

The proposed Project would not be expected to have a significant impact on electronic communications in the Study Area. Based on available data and field reconnaissance, no AM radio transmitter is located within 10,000 ft. of the Consensus Route. Additionally, no FM, cellular, or other electronic communications tower is located within 2,000 ft. of the Consensus Route.

4.2.7 Impact on Utilities

The proposed Project would not be expected to significantly impact existing utilities within the Study Area. Based on available data and field reconnaissance, existing utilities will be avoided or spanned.

4.2.8 Impact on Aesthetics

Aesthetic impacts, or impacts upon visual resources, exist when the ROW, lines, or structures of a transmission line system create an intrusion into, or substantially alter the character of, an existing scenic view. The significance of the impact is directly related to the quality of the view, in the case of natural scenic areas, or to the importance of the existing setting in the use or enjoyment of an area, in the case of valued community resources and recreational areas.

To evaluate aesthetic impacts, a field reconnaissance was conducted to determine the general aesthetic character of the area and the degree to which the proposed transmission line would be visible from selected areas. Although largely lacking in the vicinity of the Project, these areas generally include those of potential community value, parks and recreational areas, particular scenic vistas that were encountered during the field survey, and U.S. and State highways that traverse a Study Area. Measurements were made to estimate the length of the route that would fall within recreational or major highway foreground visual zones (FVZ) (0.5 mile, unobstructed). The determination of the visibility of the transmission line from various points was calculated from USGS maps and aerial imagery.

It is virtually impossible for a new transmission line not to have some visual impacts, and construction of the proposed 345 kV transmission line could have both temporary and permanent aesthetic effects. Temporary impacts would include views of the actual construction (assembly and erection of the structures) and any clearing of the ROW. Where limited clearing is required, the brush and wood debris could have a temporary negative impact on the local visual environment. Permanent impacts from the Project would include the views of the structures and lines themselves as well as views of cleared ROW.

A transmission line (structures and wires) is within the FVZ if it is visible (*i.e.*, not obstructed by terrain, trees, buildings) within 0.5 mile of an observer. The Consensus Route would not be within the FVZ of any U.S. or State highway, FM or RM road, nor any park or recreational area.

4.3 Impact on Cultural Resources

Any construction activity has the potential for adversely impacting cultural resource sites. Although this Project is currently being conducted without the need for Federal funding, permitting or assistance, Federal guidelines established under Section 106 of the National Historic Preservation Act of 1966, as amended, provide useful standards for considering the severity of possible direct and indirect impacts. According to the Secretary of the Interior's Guidelines for protection of cultural resources (36 CFR 800), adverse impacts may occur directly or indirectly when a project causes changes in archeological, architectural, or cultural qualities that contribute to a resource's historical or archeological significance.

4.3.1 Direct Impacts

Direct impacts to cultural resource sites may occur during the construction phase of the proposed transmission line and cause physical destruction or alteration of all or part of a resource. Typically, direct impacts are caused by the actual construction of the line or through increased vehicular and pedestrian traffic during the construction phase. The increase in vehicular traffic may damage surficial or shallowly buried sites, while the increase in pedestrian traffic may result in vandalism of some sites. Additionally,

construction of a transmission line may directly alter, damage, or destroy historic buildings, engineering structures, landscapes, or districts. Direct impacts may also include isolation of a historic resource from or alteration of its surrounding environment (setting).

4.3.2 Indirect Impacts

Indirect impacts include those effects caused by the Project that are farther removed in distance, or that occur later in time but are reasonably foreseeable. These indirect impacts may include introduction of visual or audible elements that are out of character with the resource or its setting. Indirect impacts may also occur because of alterations in the pattern of land use, changes in population density, accelerated growth rates, or increased pedestrian or vehicular traffic. Historic buildings, structures, landscapes, and districts are among the types of resources that might be adversely impacted by the indirect impact of the proposed transmission towers and lines.

4.3.3 Mitigation

The preferred form of mitigation for impacts to cultural resources is avoidance. An alternative form of mitigation of direct impacts can be developed for archeological and historical sites with the implementation of a program of detailed data retrieval. Indirect impacts on historical properties and landscapes can be lessened through careful design and landscaping considerations. Relocation may also be possible for some historic structures. Additionally, if contractors encounter any cultural resources, including human remains, during construction, work should cease immediately in the vicinity of the resource, the discovery reported to the THC, and action taken as directed by the THC.

4.3.4 Summary of Impact on Cultural Resources

The Study Area contains areas with a high probability for containing cultural resources; therefore, construction of the proposed transmission line has the potential to impact previously unrecorded cultural resources. One method utilized by archeologists to assess an area for the potential occurrence of cultural resources is the identification of high probability areas (HPAs). An HPA is an area considered to have a high potential for containing previously unrecorded cultural resources. When identifying HPAs, the topography and the availability of water and subsistence resources are taken into consideration. The soils and the geological processes that have occurred within the Study Area are also considered. Certain geological processes and accompanying soil deposition can protect the integrity of an archeological site by burying it within deep sediments, or alternately, sites can be destroyed through a variety of erosional processes. Understanding the geologic processes within the Study Area is useful for predicting the location of cultural resources. Locations that are usually identified as HPAs for the occurrence of prehistoric sites include water crossings, stream confluences, drainages, alluvial terraces, wide floodplains, playa lakes,

upland knolls, and areas where lithic or other subsistence resources could be found. Historic sites would be expected adjacent to historic roadways and in areas where structures appear on historic-age maps.

The identification of HPAs was accomplished by examining the TxDOT Potential Archeological Liability Map (PALM). A detailed investigation of the route was not performed by an archeologist. Therefore, some of the designated HPAs (as well as the direct and indirect impacts) may change if field archeologists conduct a visual reconnaissance or survey the route. The PALM identified areas adjacent to unnamed streams crossed by the Consensus Route as having high potential for containing previously unrecorded cultural resources. In total, 723 ft. of the Consensus Route is designated as HPA. No previously recorded cultural resource sites are crossed by the Consensus Route. One archeological site, 41EA26, is located within 1,000 ft. of the Consensus Route. This site was surveyed in 2012 and includes remnants of a historic-age farmstead. This site was determined ineligible for NRHP inclusion.

5.0 PUBLIC INVOLVEMENT ACTIVITIES

5.1 Correspondence with Agencies and Officials

Burns & McDonnell contacted the following Federal, State, and local agencies and officials by letter, dated April 24, 2020, to solicit comments, concerns, and information regarding potential environmental impacts, permits, or approvals for the construction of the proposed 345 kV transmission line within the Study Area. A map of the Study Area was included with each letter. An example of the letter mailed to the agencies and officials and copies of the responses received are included in Appendix A (Agency Correspondence).

Federal

- Natural Resources Conservation Service (NRCS)
- Federal Aviation Administration (FAA)
- U.S. Army Corps of Engineers (USACE), Fort Worth District
- Federal Emergency Management Agency (FEMA)
- U.S. Fish and Wildlife Service (USFWS)
- Environmental Protection Agency (EPA)
- Department of Defense (DoD), Siting Clearinghouse

State

- Texas Parks and Wildlife Department (TPWD)
- Texas General Land Office (GLO)
- Texas Historical Commission (THC)
- Texas Commission on Environmental Quality (TCEQ)
- West Central Texas Council of Governments (WCTCOG)
- Texas Water Development Board (TWDB)
- Texas Department of Transportation (TxDOT), Brownwood District
- TxDOT, Aviation Division
- TxDOT, Environmental Affairs Division

County

- Eastland County Judge
- Eastland County Precinct 1 Commissioner
- Eastland County Precinct 2 Commissioner
- Eastland County Precinct 3 Commissioner

- Eastland County Precinct 4 Commissioner
- Eastland County Water Supply District
- Eastland County Farm Bureau
- Eastland County Farm Service Agency

Local Jurisdictions

- Superintendent, Cisco Independent School District (ISD)

As of the date of this document, written replies to the letters sent on April 24, 2020, have been received from the following agencies and officials: NRCS, USACE, GLO, TPWD, THC, and the Eastland County Judge. Copies of all responses are included in Appendix A.

In addition to letters sent to the agencies on April 24, 2020, Burns & McDonnell reviewed the NDD Element Occurrence Records from the TPWD, the Information, Planning, and Conservation (IPaC) System from the USFWS, Texas Archeological Research Laboratory (TARL) records, and the THC Restricted Archeological Sites Atlas to verify or update cultural and natural resource records for the Study Area. All agency comments, concerns, and information received were taken into consideration by Burns & McDonnell and Lone Star in the preparation of this EA and in the evaluation of the Consensus Route. Additionally, the information received from the agencies will be taken into consideration by Lone Star before and during construction of the Project. The following is a summary of the comments provided by Federal, State, and local officials that have responded as of this writing.

- The NRCS responded with a letter dated May 28, 2020, stating that major concerns within the Study Area involve soil depth, which are shallow or moderately deep (less than 40 inches) to weakly cemented sandstone, which may require additional consideration for heavier equipment, and elevated soil salinity, that may require additional consideration for adaptive materials that resist corrosion over time. The agency also recommended reducing the impact of construction on erosion using erosion control methods and provided a Custom Soil Resources Report for Callahan and Eastland Counties.
- The USACE Fort Worth District responded with an email dated May 4, 2020, stating that the Project had been assigned a regulatory project manager and Project Number SWF-2020-00177. This was followed by a second email also dated May 4, 2020, in reference to electronic submittal procedures for the Fort Worth District Office which applies to requests for jurisdictional determinations, preconstruction notifications, nationwide and individual permit applications, no permit required requests, mitigation plans, and scoping requests. A third email was received on

May 15, 2020 stating that the USACE requires a permit for the discharge of dredged or fill material into Waters of the United States and the Agency was unable to tell from the information provided whether they would be impacted. The Agency requested a delineation of Waters of the United States including photos of any aquatic resources and the design plan for the Project.

- The GLO responded with a letter dated April 30, 2020, that the agency does not appear to have any environmental issues or land use constraints associated with the project and asked to be provided the final route so that the agency can assess the route and determine if the project will cross any streambeds or Permanent School Fund land that would require a GLO easement.
- The TPWD responded with a letter dated May 21, 2020, providing a list of species that could be impacted by proposed project activities if suitable habitat is present. The agency provided a list of regulations pertaining to the project and recommendations on how to comply with these regulations.
- The THC responded with a letter dated May 20, 2020, stating that their review determined the Project will cross an area that has never been surveyed by a professional archeologist and is likely to contain additional historical and archeological resources. The agency recommended consulting with a professional archeologist.
- The Eastland County Judge responded with a letter dated April 28, 2020, that as the County Judge and Flood Plain Administrator, he had reviewed the Project and, in his opinion, believed the Project would not adversely affect flood plain management in Eastland County, Texas. In addition, he did not believe the Project would appear to violate the County's airport zoning ordinance.

Although a letter was sent to the USFWS on April 24, 2020, this agency often no longer responds to such letters but instead requests that the applicant use the IPaC System on its website. Burns & McDonnell accessed the IPaC system on April 21, 2020, to request an Official Species List, which also generates an official consultation response letter and tracking number. IPaC identified eight federally listed species of potential occurrence in the Study Area: the endangered golden-cheeked warbler, least tern (interior population), whooping crane, sharpnose shiner, smalleye shiner, the threatened piping plover and red knot, and the candidate Texas fawnsfoot; no critical habitat was identified within the Study Area. The IPaC response letter recommended verifying the accuracy of the species after 90 days and at regular intervals during the Project planning and implementation phases for updates to the species list and information. A copy of the response letters generated by the IPaC system are included in Appendix A.

5.2 Public Open-House Meetings

Because fewer than 25 landowners would be entitled to receive direct notice of the application, Lone Star did not hold a public open-house meeting prior to filing the CCN application, consistent with PUC Procedural Rule 22.52(a)(4). Instead, Lone Star contacted the landowners directly, which has resulted in a Consensus Route for this Project.

6.0 PROJECT ASSESSMENT

In assessing potential impacts of the Project, Burns & McDonnell limited its evaluation to environmental considerations. Burns & McDonnell professionals with expertise in different environmental disciplines (terrestrial and aquatic ecology, land use/planning, and cultural resources) assessed potential impacts of the Project based on research data collected for 38 separate environmental criteria; comments from local, State, and Federal agencies; and field reconnaissance. The amount or number of each environmental criterion measured along the Consensus Route is presented in Table 6-1.

The Project is located in the northwestern portion of Eastland County, approximately six miles west-northwest of the City of Cisco, which is the county seat. No incorporated city is located within the rural Study Area, which is dominated by agricultural fields, rangeland, and shrubland. Development in the Study Area is limited to scattered and isolated single-family homes and farmsteads.

- The proposed transmission line is 12,141 ft. (2.3 miles) in length.
- No habitable structure is located within 500 ft. of the Consensus Route.
- The Consensus Route does not cross any park or recreation area, and is not located within 1,000 ft. of a park or recreational area. Additionally, the Consensus Route is not located within the foreground visual zone of parks/recreation areas.
- The Consensus Route parallels compatible ROW (CR 126) for 11,746 ft. (approximately 97% of its total length).
- The Consensus Route crosses approximately 5,835 ft. of cropland and approximately 2,815 ft. of pastureland/rangeland, none of which contains aboveground mobile irrigation systems.
- No FAA-registered airfield is located within 20,000 ft. of the Consensus Route, no private airstrip was identified within 10,000 ft. of the Consensus Route, and no heliport was identified within 5,000 ft. of the Consensus Route. The proposed Project would have little or no effect on aviation operations in the Study Area.
- No commercial AM radio transmitter occurs within 10,000 ft. of the Consensus Route and no FM radio transmitter, microwave tower, or other electronic installation is located within 2,000 ft. of the Consensus Route.

- The Consensus Route does not cross any State-maintained roadway and will not be within the foreground visual zone of U.S. or State highways, FM/RM roads, nor parks/recreation areas.
- No impacts are expected to any federally listed or proposed federally listed species, and consultation with USFWS is not expected to be necessary. One State-listed species (threatened), the Texas horned lizard is of potential occurrence in the Study Area and may occur in small numbers in suitable habitat.
- No previously recorded cultural resource site is crossed by the Consensus Route. One archeological site is located within 1,000 ft. of the Consensus Route. This site, which includes remnants of a historic-age farmstead, was determined ineligible for NRHP inclusion. The Consensus Route crosses approximately 723 ft. of HPA.

**Table 6-1: Environmental Data for Consensus Route Assessment
Reata Station to Roadrunner Crossing Wind 345 kV Transmission Line Project**

Environmental Criterion		Route Data
Land Use		
1	Length of Route	12,141
2	Number of habitable structures ^a within 500 ft. of centerline	0
3	Length of ROW utilizing existing transmission line ROW	0
4	Length of ROW parallel to existing transmission line ROW	0
5	Length of ROW parallel to other existing compatible ROW (roads, highways, railways, etc.) ^b	11,746
6	Length of ROW parallel to property lines (not following existing ROW) ^c	0
7	Length of ROW across parks/recreational areas ^d	0
8	Number of additional parks/recreational areas ^d within 1,000 ft. of ROW centerline	0
9	Length of ROW across cropland	5,835
10	Length of ROW across pastureland/rangeland	2,815
11	Length of ROW across cropland or pastureland with mobile irrigation systems	0
12	Number of pipeline crossings	0
13	Number of oil/gas wells within ROW	1
14	Number of transmission line crossings	0
15	Number of U.S. and State highway crossings	0
16	Number of FM/RM road crossings	0
17	Number of FAA-registered airfields within 20,000 ft. of ROW centerline (with runway >3,200 ft.)	0

Environmental Criterion		Route Data
18	Number of FAA-registered airfields within 10,000 ft. of ROW centerline (with runway <3,200 ft.)	0
19	Number of private airstrips within 10,000 ft. of ROW centerline	0
20	Number of heliports within 5,000 ft. of ROW centerline	0
21	Number of commercial AM radio transmitters within 10,000 ft. of ROW centerline	0
22	Number of FM radio transmitters, microwave towers, and other electronic installations within 2,000 ft. of ROW centerline	0
Aesthetics		
23	Estimated length of ROW within foreground visual zone ^e of U.S. and State highways	0
24	Estimated length of ROW within foreground visual zone ^e of FM/RM roads	0
25	Estimated length of ROW within foreground visual zone ^e of parks/recreational areas ^d	0
Ecology		
26	Length of ROW through brushland/shrubland	1,476
27	Length of ROW through bottomland/riparian woodland	620
28	Length of ROW across potential wetlands ^f	95
29	Length of ROW across known habitat of endangered or threatened species	0
30	Number of stream crossings	4
31	Length of ROW parallel to (within 100 ft.) streams	65
32	Length of ROW across open water (ponds, etc.)	0
33	Length of ROW across 100-year floodplains	340
Cultural Resources		
34	Number of recorded cultural resource sites crossed by ROW	0
35	Number of additional recorded cultural resource sites within 1,000 ft. of ROW centerline	1
36	Number of National Register of Historic Places (NRHP)-listed or determined-eligible sites crossed by ROW	0
37	Number of additional NRHP-listed or determined-eligible sites within 1,000 ft. of ROW centerline	0
38	Length of ROW crossing areas of high archeological/historical site potential	723

All length measurements in feet.

^aSingle-family and multi-family dwellings and related structures, mobile homes, apartment buildings, commercial structures, industrial structures, business structures, churches, hospitals, nursing homes, schools, or other structures normally inhabited by humans or intended to be inhabited by humans on a daily or regular basis.

^bFor purposes of this evaluation, pipelines were not considered a compatible corridor.

^cProperty lines created by existing road, highways, or railroad ROW are not “double-counted” in the “length of route parallel to property lines” criterion.

^dDefined as parks and recreational areas owned by a governmental body or an organized group, club, or church.

^e0.5 mile, unobstructed; ^fAs mapped by the U.S. Fish and Wildlife Service National Wetland Inventory.

7.0 LIST OF PREPARERS

This Environmental Assessment was prepared for Lone Star by Burns & McDonnell. Below is a list of Burns & McDonnell employees with primary responsibilities for the preparation of this document.

Responsibility	Name	Title
Project Manager	Thomas Ademski	Project Manager
Natural Resources	Gary Newgord	Environmental Scientist
Human Resources	Hunter Neblett	Environmental Scientist
Cultural Resources	Brandy Harris Shelly Fischbeck	Historian Cultural Resources Specialist
GIS/Mapping	Grant Cox	Environmental Scientist

8.0 REFERENCES

- AirNav. (2020). *Airport search*. Retrieved April 23, 2020, from <http://www.airnav.com/airports/search.html>
- AntennaSearch.com. (2020). *Online search for all towers (existing and future) and antennas*. Retrieved April 23, 2020, from <http://www.antennasearch.com/>
- Avery, M.L. (Ed.). (1978). *Impacts of transmission lines on birds in flight: proceedings of a workshop*. Oak Ridge Associated Universities. Oak Ridge, Tennessee. Inter-agency Agreement No. 40-570-76 between U.S. Department of the Interior and U.S. Department of Energy. FWS/OBS-78/48. 151 pp.
- Avian Power Line Interaction Committee (APLIC). (1994). *Mitigating bird collisions with power lines: the state of the art in 1994*. 77 pp. + apps. Washington, D.C.: Edison Electric Institute.
- . (2012). *Reducing avian collisions with power lines: the state-of-the-art in 2012*. 184 pp. + apps. Washington, D.C.: Edison Electric Institute (EEI)/Raptor Research Foundation.
- Beaulaurier, D.L. (1981). *Mitigation of bird collisions with transmission lines*. Portland, Oregon: Bonneville Power Administration.
- Blackmar, M., and J.L. Hofman. (2006). Paleoarchaic of Kansas. In R.J Hoard and W.E. Banks (Eds.), *Kansas Archeology*. Lawrence: University Press of Kansas. Published in association with the Kansas State Historical Society.
- Blair, W.F. (1950). The biotic provinces of Texas. University of Texas. *Journal of Science* 2, 93–117.
- Boyd, D.K. (2004). The Palo Duro Complex. In *The Prehistory of Texas*. College Station: Texas A&M University Press. Anthropology Series, No. 9.
- Bradley, R.D., L.K. Ammerman, R.J. Baker, L.C. Bradley, J.A. Cook, R.C. Dowler, C. Jones, D.J. Schmidly, F.B. Stangl, Jr., R.A. Van Den Bussche, and B. Würsig. (2014). *Revised Checklist of North American Mammals North of Mexico*. Museum of Texas Tech University. Number 327.
- Brooks, R. (2004). From Stone Slab architecture to abandonment. In *The Prehistory of Texas*. College Station: Texas A&M University Press. Anthropology Series, No. 9.
- Brosowske, S.D. (2005). *The evolution of exchange in small-scale societies of the Southern High Plains*. PhD Dissertation. Norman: University of Oklahoma, Department of Anthropology.
- Bureau of Economic Geology (BEG). (1972). *Geologic atlas of Texas. Abilene Sheet*. The University of Texas at Austin.
- . (1976). *Energy resources of Texas*. The University of Texas at Austin, Bureau of Economic Geology.
- . (1979). *Mineral resources of Texas*. The University of Texas at Austin, Bureau of Economic Geology.
- . (1996). *Physiographic Map of Texas*. The University of Texas at Austin.

- Campbell, L. (2003). *Endangered and threatened animals of Texas. Their life history and management*. Texas Parks and Wildlife Department. Retrieved May 5, 2020, from https://tpwd.texas.gov/publications/pwdpubs/media/pwd_bk_w7000_0013.pdf
- Canadian Wildlife Service (CWS) and U.S. Fish and Wildlife Service (USFWS). (2007). *International recovery plan for the whooping crane*. Ottawa: Recovery of National Endangered Wildlife (RENEW) and Albuquerque, New Mexico: U.S. Fish and Wildlife Service. 162 pp.
- Carlson, P. (2005). *Deep time and the Texas High Plains history and geology*. Lubbock: Texas Tech University Press.
- Cell Reception. (2020). *Search for cell towers*. Retrieved April 23, 2020, from <http://www.cellreception.com/towers/>
- Chesser, R.T., K.J. Burns, C. Cicero, J.L. Dunn, A.W. Kratter, I.J. Lovette, P.C. Rasmussen, J.V. Remsen, Jr., D.F. Stotz, and K. Winker. (2019). *Check-list of North American birds (online)*. American Ornithological Society. Retrieved May 5, 2020, from <http://checklist.aou.org/taxa/>
- Chippindale, P.T., A.H. Price, J.J. Wiens, and D.M. Hillis. (2000). Phylogenetic relationships and systematic revision of central Texas hemidactyliline plethodontid salamanders. *Herpetological Monographs*, 14 (2000): 1–80.
- Cornell Lab of Ornithology. (2020). *All About Birds: Piping Plover*. Retrieved May 4, 2020, from http://www.allaboutbirds.org/guide/piping_plover/id
- Cowardin, L.M., V. Carter, F.C. Golet, and E.T. LaRoe. (1979). *Classification of wetlands and deepwater habitats of the United States*. FWS/OBS-79/31. Performed for Office of Biological Services, Fish and Wildlife Service, U.S. Department of the Interior.
- Crother, B.I., R.M. Bonett, J. Boundy, F.T. Burbrink, K. De Queiroz, D.R. Frost, R. Highton, J.B. Iverson, E.L. Jokusch, F. Kraus, K.L. Krysko, A.D. Leaché, E. Lemmon, R.W. McDiarmid, J.R. Mendelson III, P.A. Meylan, T.W. Reeder, S. Ruane, and M.E. Seidel. (2017). *Scientific and standard English names of amphibians and reptiles of North America north of Mexico, with comments regarding confidence in our understanding. Eighth edition*. Society for the Study of Amphibians and Reptiles, Herpetological Circular No. 43.
- Dixon, J.R. (2013). *Amphibians and reptiles of Texas*. College Station: Texas A&M University Press.
- eBird. (2020). *eBird: An online database of bird distribution and abundance*. Web application. Ithaca, New York: Cornell Lab of Ornithology. Retrieved May 2020 from <http://www.ebird.org>
- Electric Power Research Institute (EPRI). (1993). *Proceedings: avian interactions with utility structures*. International Workshop, Miami, Florida, September 13–16, 1992. EPRI TR-103268, Palo Alto, California.
- Erickson, W.P., G.D. Johnson, and D.P. Young, Jr. (2005). *A summary and comparison of bird mortality from anthropogenic causes with an emphasis on collisions*. USDA Forest Service Gen. Tech. Rep. PSW-GET-191:1029–1042. Cheyenne, Wyoming: Western Ecosystems Technology, Inc.
- Federal Aviation Administration (FAA). (2011). *Federal aviation regulations, Part 77.9. Safe, Efficient Use, and Preservation of the Navigable Airspace. Construction or Alteration Requiring Notice*. Retrieved

- from <https://www.federalregister.gov>.
http://rgl.faa.gov/Regulatory_and_Guidance_Library/rgFAR.nsf/MainFrame?OpenFrameSet
- . (2020). National Aeronautical Charting Office. *Dallas-Ft Worth Sectional*, 104th Edition. Effective February 27, 2020, to September 10, 2020. Retrieved April 23, 2020, from <http://skyvector.com/>
- Federal Communication Commission (FCC). (2015). *Opportunities to reduce bird collisions with communications towers while reducing tower lighting costs*. Federal Communications Commission, Washington, D.C. December 22, 2015.
- . (2020). *FCC search tools. AM, FM, and TV tower search*. Retrieved April 23, 2020, from <http://www.fcc.gov/searchtools.html>
- Federal Emergency Management Agency (FEMA). (2020). FEMA: *National flood hazard layer (WMS) for Eastland County, Texas*. Accessed May 2020.
- Find a Grave. (2020). Electronic document. Retrieved April 20, 2020, from <https://www.findagrave.com/cemetery/3270/dothan-cemetery>
- Gauthreaux, S.A., Jr. (1978). Migratory behavior and flight patterns. In M.L. Avery (Ed.), *Impacts of transmission lines on birds in flight – proceedings of a workshop* (pp. 12–26). Washington, D.C.: U.S. Fish and Wildlife Service.
- Gould, F.W., G.O. Hoffman, and C.A. Rechenstien. (1960). *Vegetational areas of Texas*. Texas Agricultural Extension Service. L-492.
- Griffith, G., S. Bryce, J. Omernik, and A. Rogers. (2007). *Ecoregions of Texas*. Retrieved May 2020 from ftp://newftp.epa.gov/EPADDataCommons/ORD/Ecoregions/tx/TXeco_Jan08_v8_Cmprsd.pdf
- Harrison, B.R. and K.L Killen. (1978). *Lake Theo: A stratified, early man bison butchering and camp site, Briscoe County, Texas*. Archeological Investigations, Phase II. Panhandle-Plains Historical Museum, West Texas State University, Canyon.
- Hatch, S.L., K.N. Gandhi, and L.E. Brown. (1990). *Checklist of the vascular plants of Texas*. College Station: Texas Agricultural Experiment Station.
- Henke, S.E., and W.S. Fair. (1998). *Management of Texas Horned Lizards*. Kingsville: Texas A&M University. Retrieved May 5, 2020, from <https://www.ckwri.tamuk.edu/sites/default/files/pdf-attachment/2016-05/bulletin2.pdf>
- Hofman, J.L. (1989). Prehistoric Culture History—Hunters and Gatherers in the Southern Great Plains. In *From Clovis to Comanchero: Archeological Overview of the Southern Great Plains*, by J. Hofman, R.L. Brooks, J.S. Hays, D.W. Owsley, R.L. Jantz, M.K. Marks, and M.H. Manhein (pp. 25–60). Research Series Number 35. Arkansas Archeological Survey, Fayetteville.
- Hubbs, C., R.J. Edwards, and G.P. Garrett. (2008). An annotated checklist of the freshwater fishes of Texas, with keys to identification of species. 2nd Edition. *Texas Journal of Science* 43(4), 1–87.

- Johnson, E., and V. Holliday. (2004). Archeology and Late Quaternary Environments of the Southern High Plains. In *The Prehistory of Texas*. College Station: Texas A&M University Press. Anthropology Series, No. 9.
- Kay, M. (1998). The Central and Southern Plains Archaic. In W.R. Wood (Ed.), *Archeology on the Great Plains* (pp. 173–200). Lawrence: University Press of Kansas.
- Ladd, C., and L. Gass. (1999). Golden-cheeked warbler (*Dendroica chrysoparia*). In A. Poole and F. Gill (Eds.), *The birds of North America*, No. 420. Philadelphia: The Birds of North America, Inc.
- Leffler, J. (2019). *Eastland County*. *Handbook of Texas Online*. Retrieved April 2020, from <https://tshaonline.org/handbook/online/articles/hce01>
- Lewis, J.C. (1995). Whooping crane (*Grus americana*). In A. Poole and F. Gill (Eds.), *The birds of North America*, No. 153. Philadelphia: The Academy of Natural Sciences, and Washington, D.C.: American Ornithologists' Union.
- Lockwood, M.W., and B. Freeman. (2014). *The TOS handbook of Texas birds*. College Station: Texas A&M University Press.
- Mercado-Allinger, P.A., N.A. Kenmotsu, and T.K. Pertulla (Eds.). (1996). *Archeology in the Central and Southern Planning Region, Texas: a planning document*. Office of the State Archeologist, Special Report 35 and Cultural Resource Management Report 7, Department of Antiquities Protection, Texas Historical Commission, Austin, TX.
- National Conservation Easement Database (NCED). (2020). *Explore, Interactive Map*. Retrieved April 23, 2020, from <https://www.conservationeasement.us/state-profiles/>
- National Park Service. (2020). *Find a park*. U.S. Department of the Interior. Retrieved April 23, 2020, from <http://www.nps.gov/findapark/index.htm>
- Natural Resources Conservation Service (NRCS). (2019). *Soil Data Mart*. Query for Prime Farmland Soils in Eastland and Callahan Counties. Retrieved from <http://soildatamart.nrcs.usda.gov/>
- New York Power Authority. (2005). *Estimates of bird mortality associated with transmission lines*. Niagara Power Project FERC No. 2216. 24 pp. Retrieved from <http://niagara.nypa.gov/ALP%20working%20documents/finalreports/IS14.pdf>
- Oberholser, H.C. (1974). *The bird life of Texas*. 2 Vols. Austin: University of Texas Press.
- Pertulla, T.K. (2004). *Prehistory of Texas*. College Station: Texas A&M University Press.
- Public Utility Commission of Texas (PUC). (2015). *Certification criteria*. Chapter 25. Subchapter E. Certification, Licensing and Registration.
- Purvis, J. (2018a). *Big game harvest survey results 2005–06 thru 2017–18*. Austin: Texas Parks and Wildlife Department, Austin. June 26, 2018.
- . (2018b). *Small game harvest survey results 1998–99 through 2017–18*. Austin: Texas Parks and Wildlife Department, Austin. July 10, 2018.

- Railroad Commission of Texas (RRC). (2020a). *GIS public map viewer of oil/gas wells and pipelines*. Retrieved May 5, 2020, from <http://gis2.rrc.state.tx.us/public/startit.htm>
- . (2020b). *GIS public map viewer of oil/gas wells and pipelines*. Retrieved April 23, 2020, from <http://www.rrc.state.tx.us/about-us/resource-center/research/gis-viewers/>
- Rochelle, J.A., L.A. Lehmann, and J. Wisniewski. (1999). *Forest fragmentation: wildlife and management implications*. 303+ pages.
- Ryder, R.A., and D.E. Manry. (1994). White-faced ibis (*Plegadis chihi*). In A. Poole and F. Gill (Eds.), *The birds of North America, No. 130*. Philadelphia: The Academy of Natural Sciences, and Washington, D.C.: American Ornithologists' Union.
- Schmidly, D.J. and R. D. Bradley. (2016). *The mammals of Texas, 7th edition*. Austin: University of Texas Press.
- Soil Conservation Service (SCS). (1977). U.S. Department of Agriculture. *Soil survey of Eastland County, Texas*. In cooperation with the Texas Agricultural Experiment Station.
- . (1981). U.S. Department of Agriculture. *Soil survey of Callahan County, Texas*. In cooperation with the Texas Agricultural Experiment Station.
- Tacha, M., A. Bishop, and J. Brei. (2010). *Development of the whooping crane tracking project geographic information system*. Proceedings of the North American Crane Workshop 11, 98–104.
- Tennant, A. (1998). *A field guide to Texas snakes*. Houston: Gulf Publishing Company; 2nd edition.
- Texas Association of Regional Councils (TARC). (2020). *West Central Texas Council of Governments*. Retrieved April 23, 2020, from <http://txregionalcouncil.org/regional-council/west-central-texas-council-of-governments/>
- Texas Department of Transportation (TxDOT). (1998). Scenic overlooks and rest areas. *Texas Highways Magazine, Vol. 45, No. 8*. Austin, Texas.
- . (2020a). *Texas highway designation files*. Retrieved April 23, 2020, from <https://www.dot.state.tx.us/tpp/search/query.htm>
- . (2020b). *Texas airport directory*. Retrieved April 23, 2020, from <http://txdot.gov/inside-txdot/division/aviation/airport-directory-list.html>
- Texas Education Agency (TEA). (2020). *School district locator*. Map. Retrieved April 23, 2020, from <http://tea.texas.gov/>
- Texas Historical Commission (THC). (2020). *Texas Forts Trail Region*. Retrieved April 23, 2020, from <https://texasfortstrail.com/>
- Texas Parks and Wildlife Department (TPWD). (1984). *1985 Texas Outdoor Recreation Plan (TORP)*. Comprehensive Planning Branch, Parks Division, Austin.
- . (2009). *15 Texas freshwater mussels placed on State threatened list. News Release: November 5, 2009*. Retrieved May 12, 2020, from <https://tpwd.texas.gov/newsmedia/releases/?req=20091105c>

- . (2020a). *Ecologically significant river and stream segments*. Retrieved May 5, 2020, from http://tpwd.texas.gov/landwater/water/conservation/water_resources/water_quantity/sigsegs/listofreports.phtml
- . (2020b). *Ecological mapping systems*. Retrieved May 4, 2020, from <https://tpwd.texas.gov/landwater/land/programs/landscape-ecology/ems/>
- . (2020c). *Rare, threatened, and endangered species of Texas by county*. Retrieved April 21, 2020, from <http://www.tpwd.state.tx.us/gis/ris/es/>
- . (2020d). *Texas Natural Diversity Database (TXNDD) Rare species, shapefiles, and element of occurrence records*. Retrieved April 21, 2020.
- . (2020e). *Find a park*. Texas State Parks – Interactive Travel Regions Map. Retrieved April 23, 2020, from <http://www.tpwd.state.tx.us/spdest/findadest/>
- Texas State University. (2018). *Notropis oxyrhynchus -- sharpnose shiner*. Retrieved August 15, 2018, from <http://txstate.fishesoftexas.org/notropis%20oxyrhynchus.htm>
- Texas Water Development Board (TWDB). (2007). *Water for Texas, a consensus-based update to the State Water Plan, Vol. 2, Technical Planning Appendix*. Austin.
- . (2012). *Water for Texas 2012 State Plan*.
- . (2020). *Brazos River Basin*. Retrieved May 8, 2020, from https://www.twdb.texas.gov/surfacewater/rivers/river_basins/brazos/index.asp
- Thomas, C., T.H. Bonner, B.G. Whiteside, A. Sansom, and F. Gelwick. (2007). *Freshwater Fishes of Texas: A Field Guide*. College Station: Texas A&M University Press.
- Thompson, B.C., J.A. Jackson, J. Burger, L. Hill, E.M. Kirsch, and J.L. Atwood. (1997). Least tern (*Sterna antillarum*). In A. Poole and F. Gill (Eds.), *The Birds of North America, No. 290*. Philadelphia: The Academy of Natural Sciences, and Washington, D.C.: American Ornithologists' Union.
- Thompson, L.S. (1978). Transmission line wire strikes: mitigation through engineering design and habitat modification. In M.L. Avery (Ed.), *Impacts of transmission lines on birds in flight: proceedings of a workshop* (pp. 27–52). Tennessee: Oak Ridge Associated Universities. Interagency Agreement No. 40-570-76.
- U.S. Army Corps of Engineers (USACE). (2020). *Regulatory In-Lieu Fee and Bank Information Tracking System, OpenLayers Map*. Retrieved April 23, 2020, from <https://ribits.ops.usace.army.mil/ords/f?p=107:2:3529040705986::NO::>
- U.S. Census Bureau. (2020). *Explore Census Data. 2019 population estimates of Eastland County*. Retrieved April 23, 2020, from <https://data.census.gov/cedsci/>
- U.S. Department of Agriculture (USDA). (2012). *The 2012 census of agriculture – State and county profiles*. National Agricultural Statistics Service. Retrieved April 23, 2020, from http://www.agcensus.usda.gov/Publications/2012/Full_Report/Volume_1,_Chapter_2_County_Level/Texas/

- . (2019a). *National Agricultural Statistics Service. Cropscape-cropland data layer*. Retrieved April 21, 2020, from <https://nassgeodata.gmu.edu/CropScape>
- . (2019b). *The 2017 census of agriculture – State and county profiles*. National Agricultural Statistics Service. Retrieved April 23, 2020, from https://www.nass.usda.gov/Publications/AgCensus/2017/Online_Resources/County_Profiles/index.php
- U.S. Fish and Wildlife Service (USFWS), Department of the Interior. (1973). *Endangered Species Act (ESA)*. 1973. Title 16 United States Code, Sections 1531–1544.
- . (1995). *Threatened and endangered species of Texas*. Austin. June.
- . (2009a). *Whooping cranes and wind development – an issue paper*. Regions 2 and 6. http://www.fws.gov/southwest/es/oklahoma/documents/te_species/wind%20power/whooping%20crane%20and%20wind%20development%20fws%20issue%20paper%20-%20final%2020april%202009.pdf
- . (2009b). *Confirmed whooping crane sightings thru SP09 (shapefile)*. Unpublished data (updated November 17, 2009). Received from the USFWS, Austin, Texas Ecological Services Field Office.
- . (2011). *Endangered and threatened wildlife and plants: findings for petitioned candidate species – red knot (Calidris canutus rufa)*. U.S. Fish and Wildlife Service, Department of the Interior. *Federal Register*, Vol. 76, No. 207.
- . (2014). *Species status assessment report for sharpnose shiner (Notropis oxyrhynchus) and smalleye shiner (N. buccula)*. USFWS, Arlington. Retrieved May 8, 2020, from https://www.fws.gov/southwest/es/ArlingtonTexas/pdf/20140721%20SSA-Report_Brazos-Shiners.pdf
- . (2015). *Recovery outline for sharpnose shiner and smalleye shiner*. USFWS, Arlington. Retrieved May 8, 2020, from https://ecos.fws.gov/docs/recovery_plan/Final%20Sharpnose%20and%20Smalleye%20Shiner%20Recovery%20Outline.pdf
- . (2016). *Federal Register/ Vol. 81, No. 232/Friday, December 2, 2016*. Retrieved May 12, 2020, from <https://www.govinfo.gov/content/pkg/FR-2016-12-02/pdf/2016-28817.pdf#page=1>
- . (2020a). *IPaC – Information, Planning, and Conservation System*. Retrieved from <http://ecos.fws.gov/ipac/>
- . (2020b). *Listed species believed to or known to occur in Texas*. Retrieved May 5, 2020, from: <https://ecos.fws.gov/ecp0/reports/species-listed-by-state-report?state=TX&status=listed>
- U.S. Geological Survey (USGS). (1966, 2010, 2012). *Bernie Lake, Texas. 1: 24, 000 Topographic Quadrangle Map*. Reston, Virginia.
- . (2011). *The USGS Mineral Data Resource System*. Retrieved May 5, 2020, from <https://mrdata.usgs.gov/mrds/>

———. (2020). Protected Areas Database of the United States (PAD-US). Retrieved April 23, 2020, from <https://maps.usgs.gov/padus/>

Werler, J.E., and J.R. Dixon. (2000). *Texas snakes*. Texas Natural History Guides. Austin: University of Texas Press.

Willard, D.E. (1978). The impact of transmission lines on birds (and vice versa). In M.L. Avery (Ed.), *Impacts of transmission lines on birds in flight – proceedings of a workshop* (pp. 3–7). Washington, D.C.: U.S. Fish and Wildlife Service.

APPENDIX A - AGENCY CORRESPONDENCE



April 24, 2020

Attn:
Title:
Agency:
Street Address:
City, State, Zip Code:

Re: Request for Information
Lone Star Transmission, LLC Roadrunner Crossing Wind to Reata Station
345-kV Transmission Line Project

Dear _____:

Lone Star Transmission, LLC (Lone Star) is proposing to design and construct a new 345-kilovolt (kV) electric transmission line in the northwestern portion of Eastland County, Texas to interconnect a proposed wind generation development. The proposed transmission line would be constructed between the proposed Roadrunner Crossing Wind collector substation, located southeast of the County Road (CR) 125 and CR 126 intersection, to the proposed Lone Star Reata Station, which will be located north of Lone Star's existing West Shackelford to Romney 345-kV CREZ transmission line, on the east side of CR 126 (approximately 1.1 mile north of FM 2945). Please reference the proposed substation locations within the study area depicted on the attached map. The proposed transmission line will be approximately 2.4 miles in length and will require a right-of-way between 100 to 150 feet in width.

Burns & McDonnell is preparing an Environmental Assessment (EA) for the proposed project that will support Lone Star's application for a Certificate of Convenience and Necessity from the Public Utility Commission of Texas. Burns & McDonnell is in the process of collecting and evaluating environmental data for the study area. As part of this effort, we are asking that your agency/office relate any environmental or land use concerns that you may have regarding the siting and potential environmental effects from the construction of the proposed line in the designated study area.

Additionally, if any permits, easements, or other approvals by your agency/office are required, or if you are aware of any major proposed development or construction in the study area, we would also appreciate receiving this information as well.

Your input on any of the following resources as they relate to your agency or office will assist the project team in evaluating the proposed project:

- Land use (current or proposed land development projects, park/recreation areas, etc.)
- Aesthetics
- Water quality and wetlands
- Soils and geology



- Wildlife, vegetation, and fisheries (including threatened and endangered species)
- Socioeconomics (population, employment, growth, current/future development)
- Cultural resources (historic and archeological)
- Transportation and roads (airport and roadway expansions, construction, operations, and maintenance)

Burns & McDonnell would like to thank you in advance for your comments, which will be an important consideration in our assessment of potential environmental and land use impacts of the proposed transmission line. If you have any questions concerning this project or our request for information, please contact me at tjademski@burnsmcd.com or 512-731-1526. Your earliest reply will be appreciated.

Sincerely,

A handwritten signature in black ink, appearing to read 'Thomas J. Ademski'.

Thomas J. Ademski
Project Manager

TA/ta

Attachment

cc: Trey Hadley, NextEra Energy – Environmental Services
Kelly Wells, Lone Star Transmission, LLC

Callahan County

Eastland County

880

CR 314

Proposed Roadrunner Crossing
Wind Collector Station

CR 126

CR 107

West Shackelford to Romney 345-kV Line



Proposed Reata Station

CR 126

2945

2945



-  Project Endpoint
-  Existing Transmission Line
-  Study Area



0 2,000 4,000
Feet



Roadrunner Crossing Wind
to Reata Station
345-kV Transmission Line
Lone Star Transmission
Eastland County, Texas

Path: \\data\projects\ESP\ONE STAR TRANSMISSION\Roadrunner 345kV\Geospatial\DataFiles\ArcDocs\Roadrunner_agency_contact_map.mxd gacox 4/23/2020
Service Layer Credits: Source: Esri, DigitalGlobe, GeoEye, Earthstar Geographics, CNES/Airbus DS, USDA, USGS, AeroGRID, IGN, and the GIS User Community

OFFICIALS/AGENCIES CONTACTED

LONE STAR ROADRUNNER CROSSING WIND TO REATA STATION 345-KV TRANSMISSION LINE PROJECT

FEDERAL

Tony Robinson
Regional Administrator
Region VI
Federal Emergency Management Agency
FRC 800 North Loop 288
Denton, TX 76209-3698

Drenda Williams
State Conservationist (Acting)
Natural Resources Conservation Service
101 South Main St.
Temple, TX 76501

Laura Broyles
Assistant State Conservationist
Administrative Zone 5 – Weatherford Office
Natural Resources Conservation Service
532 Santa Fe Drive
Weatherford, TX 76086

Debra Bills
Field Supervisor
Arlington Ecological Services Field Office
U.S. Fish and Wildlife Service
2005 Northeast Green Oaks Boulevard
Suite 140
Arlington, TX 76006

Stephen Brooks
Chief, Regulatory Branch
Fort Worth District
U.S. Army Corps of Engineers
819 Taylor Street
Fort Worth, TX 76102

Ken McQueen
Regional Administrator
Region 6 – South Central
U.S. Environmental Protection Agency
1201 Elm Street
Suite 500
Dallas, TX 75270

Obstruction Evaluation Group
Federal Aviation Administration
Southwest Region
10101 Hillwood Parkway
Fort Worth, TX 76117-1524

Department of Defense Siting Clearinghouse
3400 Defense Pentagon, Room 5C646
Washington, DC 20301-3400
osd.dod-siting-clearinghouse@mail.mil

STATE

Carter Smith
Executive Director
Texas Parks and Wildlife Department
4200 Smith School Road
Austin, TX 78744

Laura Zebehazy
Program Leader
Wildlife Habitat Assessment Program
Texas Parks and Wildlife Department
4200 Smith School Road
Austin, TX 78744

George P. Bush
Texas Land Commissioner
Texas General Land Office
1700 North Congress Avenue
Suite 935
Austin, TX 78701-1495

Winona Henry, P.E.
Regional Director, Region 3
Texas Commission on Environmental Quality
1977 Industrial Blvd.
Abilene, TX 79602-7833

Mark Wolfe
Executive Director
Texas Historical Commission
P.O. Box 12276
Austin, TX 78711

OFFICIALS/AGENCIES CONTACTED

LONE STAR ROADRUNNER CROSSING WIND TO REATA STATION 345-KV TRANSMISSION LINE PROJECT

Jessica Zuba
Deputy Executive Administrator
Water Supply and Infrastructure
Texas Water Development Board
P.O. Box 13231
Austin, TX 78711-3231

Elias Rmeili, P.E.
District Engineer
Brownwood District
Texas Department of Transportation
2495 Highway 183 North
Brownwood, TX 76802

Dan Harmon
Interim Director
Aviation Division
Texas Department of Transportation
125 East 11th Street
Austin, TX 78701

Carlos Swonke
Director
Environmental Affairs Division
Texas Department of Transportation
125 East 11th Street
Austin, TX 78701-2483

Tom Smith
Executive Director – Region 7
West Central Texas Council of Governments
3702 Loop 322
Abilene, TX 79602-7300

EASTLAND COUNTY

The Honorable Rex Fields
Eastland County Judge
100 W. Main, Suite 203
Eastland, TX 76448

Andy Maxwell
Eastland County Precinct 1 Commissioner
Commissioners Court
100 W. Main, Suite 203
Eastland, TX 76448

James Crenshaw
Eastland County Precinct 2 Commissioner
Commissioners Court
100 W. Main, Suite 203
Eastland, TX 76448

Ronnie Wilson
Eastland County Precinct 3 Commissioner
Commissioners Court
100 W. Main, Suite 203
Eastland, TX 76448

Robert Rains
Eastland County Precinct 4 Commissioner
Commissioners Court
100 W. Main, Suite 203
Eastland, TX 76448

Steve Gerdes
President
Eastland County Water Supply District
P.O. Box 16
Ranger, TX 76470

Andrew Schneider
Agency Manager
Eastland County Farm Bureau
P.O. Box 470
Eastland, TX 76448

John Bird
Executive Director
Eastland County Farm Service Agency
401 Pogue Avenue
Eastland, TX 76448

LOCAL

Dr. Ryan Steele
Cisco ISD Superintendent
Cisco Independent School District
P.O. Box 1645
Cisco, TX 76437



Natural Resources
Conservation Service

State Office

101 S. Main Street
Temple, TX 76501
Voice 254.742.9800
Fax 254.742.9819

May 12, 2020

Burns McDonnell
tjademski@burnsmcd.com

Attention: Thomas J. Ademski, Project Manager, *via email*

Subject: LNU-Farmland Protection
Proposed Roadrunner Crossing Wind to Reata Station 345-kV
Transmission Line Project
Environmental Assessment of Natural Resources
Callahan and Eastland Counties, Texas

We have reviewed the information provided in your correspondence dated April 24, 2020 concerning the proposed transmission line project located in Callahan and Eastland Counties, Texas. We have evaluated the proposed site and provided technical resources related to soil and land use limitations for consideration within an Environmental Assessment (EA).

The proposed site does not involve USDA-NRCS Wetland Reserve Easements (WRE), a component of the Agricultural Conservation Easement Program (ACEP).

Please find the attached Custom Soil Resources Report. The soil physical and chemical properties are presented, along with additional restrictions or interpretations for the project area.

The major concerns within the study area involve soil depth and soil salinity. The majority of the soils within the study area are shallow or moderately deep (less than 40 inches) to weakly cemented sandstone, which may require additional consideration for heavier equipment. Additionally, the corrosion of steel report indicates that many of the soils have elevated salinity values, which is inherent of the sandstone parent material. This may involve additional consideration for adaptive materials that resist corrosion over time.

To reduce erosion during construction, we strongly recommend the use of approved erosion control methods, including the use of erosion control equipment near heavily disturbed soil and reducing the amount of bare ground.

If you have further questions, please contact me at 254.742.9836 or by email at Carlos.Villarreal@usda.gov (Preferred).

Sincerely,

2020.05.28

08:46:57 -05'00'



Carlos J. Villarreal
NRCS Soil Scientist

Attachment: Custom Soil Resource Report for Callahan and Eastland Counties, Texas

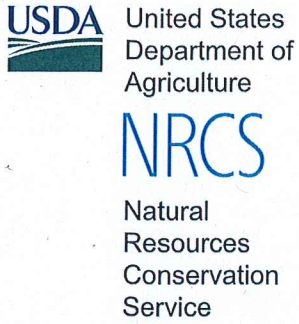

A product of the National Cooperative Soil Survey, a joint effort of the United States Department of Agriculture and other Federal agencies, State agencies including the Agricultural Experiment Stations, and local participants

Custom Soil Resource Report for Callahan County, Texas, and Eastland County, Texas

Lone Star Transmission, LLC Study Area

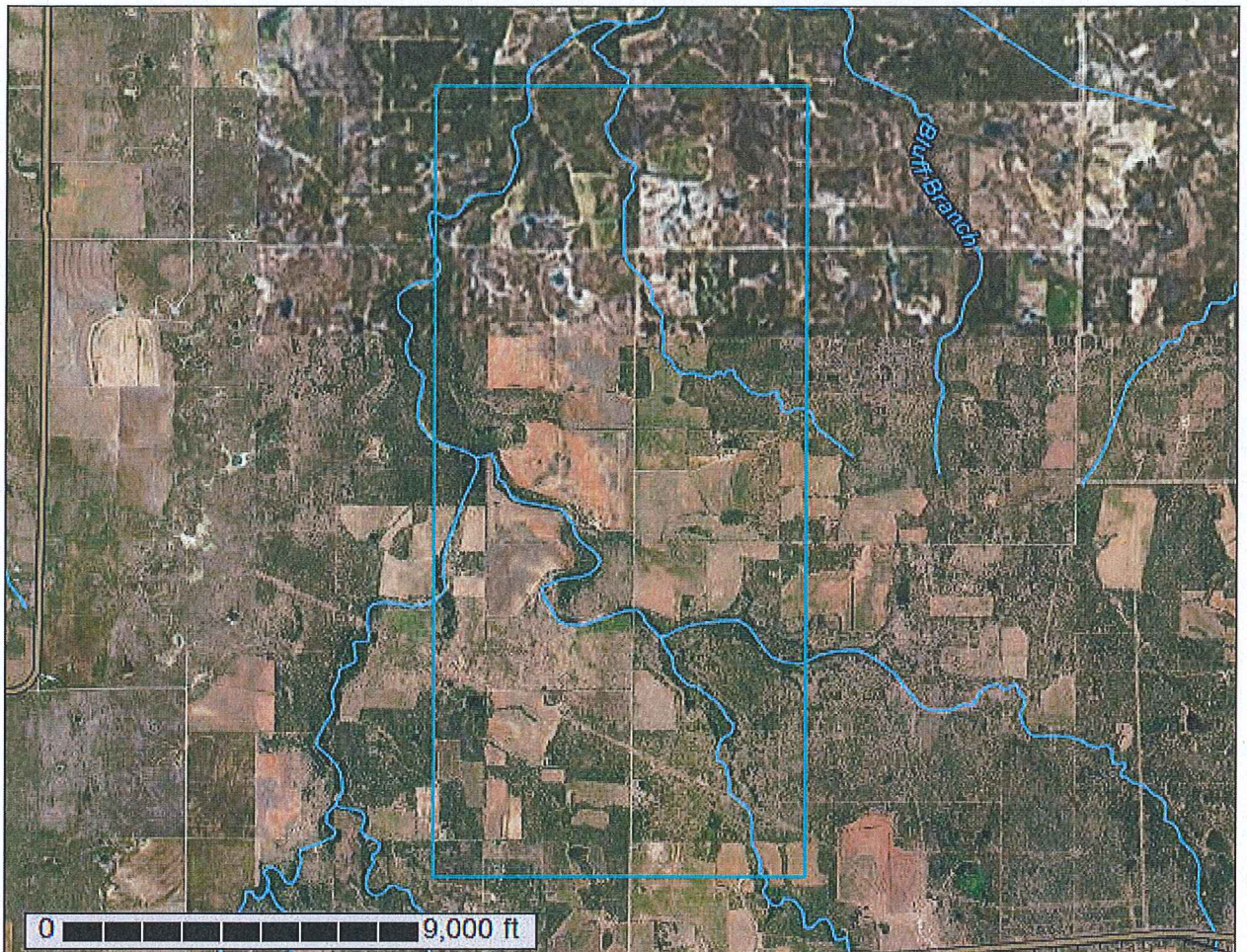

Preface

Soil surveys contain information that affects land use planning in survey areas. They highlight soil limitations that affect various land uses and provide information about the properties of the soils in the survey areas. Soil surveys are designed for many different users, including farmers, ranchers, foresters, agronomists, urban planners, community officials, engineers, developers, builders, and home buyers. Also, conservationists, teachers, students, and specialists in recreation, waste disposal, and pollution control can use the surveys to help them understand, protect, or enhance the environment.

Various land use regulations of Federal, State, and local governments may impose special restrictions on land use or land treatment. Soil surveys identify soil properties that are used in making various land use or land treatment decisions. The information is intended to help the land users identify and reduce the effects of soil limitations on various land uses. The landowner or user is responsible for identifying and complying with existing laws and regulations.

Although soil survey information can be used for general farm, local, and wider area planning, onsite investigation is needed to supplement this information in some cases. Examples include soil quality assessments (<http://www.nrcs.usda.gov/wps/portal/nrcs/main/soils/health/>) and certain conservation and engineering applications. For more detailed information, contact your local USDA Service Center (<https://offices.sc.egov.usda.gov/locator/app?agency=nrcs>) or your NRCS State Soil Scientist (http://www.nrcs.usda.gov/wps/portal/nrcs/detail/soils/contactus/?cid=nrcs142p2_053951).

Great differences in soil properties can occur within short distances. Some soils are seasonally wet or subject to flooding. Some are too unstable to be used as a foundation for buildings or roads. Clayey or wet soils are poorly suited to use as septic tank absorption fields. A high water table makes a soil poorly suited to basements or underground installations.

The National Cooperative Soil Survey is a joint effort of the United States Department of Agriculture and other Federal agencies, State agencies including the Agricultural Experiment Stations, and local agencies. The Natural Resources Conservation Service (NRCS) has leadership for the Federal part of the National Cooperative Soil Survey.

Information about soils is updated periodically. Updated information is available through the NRCS Web Soil Survey, the site for official soil survey information.

The U.S. Department of Agriculture (USDA) prohibits discrimination in all its programs and activities on the basis of race, color, national origin, age, disability, and where applicable, sex, marital status, familial status, parental status, religion, sexual orientation, genetic information, political beliefs, reprisal, or because all or a part of an individual's income is derived from any public assistance program. (Not all prohibited bases apply to all programs.) Persons with disabilities who require

alternative means for communication of program information (Braille, large print, audiotape, etc.) should contact USDA's TARGET Center at (202) 720-2600 (voice and TDD). To file a complaint of discrimination, write to USDA, Director, Office of Civil Rights, 1400 Independence Avenue, S.W., Washington, D.C. 20250-9410 or call (800) 795-3272 (voice) or (202) 720-6382 (TDD). USDA is an equal opportunity provider and employer.

Contents

Preface	2
Soil Information for All Uses	5
Suitabilities and Limitations for Use.....	5
Building Site Development.....	5
Corrosion of Steel (Lone Star Transmission, LLC Study Area).....	5
Soil Properties and Qualities.....	12
Soil Qualities and Features.....	12
Depth to Any Soil Restrictive Layer (Lone Star Transmission, LLC Study Area).....	12

Soil Information for All Uses

Suitabilities and Limitations for Use

The Suitabilities and Limitations for Use section includes various soil interpretations displayed as thematic maps with a summary table for the soil map units in the selected area of interest. A single value or rating for each map unit is generated by aggregating the interpretive ratings of individual map unit components. This aggregation process is defined for each interpretation.

Building Site Development

Building site development interpretations are designed to be used as tools for evaluating soil suitability and identifying soil limitations for various construction purposes. As part of the interpretation process, the rating applies to each soil in its described condition and does not consider present land use. Example interpretations can include corrosion of concrete and steel, shallow excavations, dwellings with and without basements, small commercial buildings, local roads and streets, and lawns and landscaping.

Corrosion of Steel (Lone Star Transmission, LLC Study Area)

"Risk of corrosion" pertains to potential soil-induced electrochemical or chemical action that corrodes or weakens uncoated steel. The rate of corrosion of uncoated steel is related to such factors as soil moisture, particle-size distribution, acidity, and electrical conductivity of the soil. Special site examination and design may be needed if the combination of factors results in a severe hazard of corrosion. The steel in installations that intersect soil boundaries or soil layers is more susceptible to corrosion than the steel in installations that are entirely within one kind of soil or within one soil layer.

The risk of corrosion is expressed as "low," "moderate," or "high."

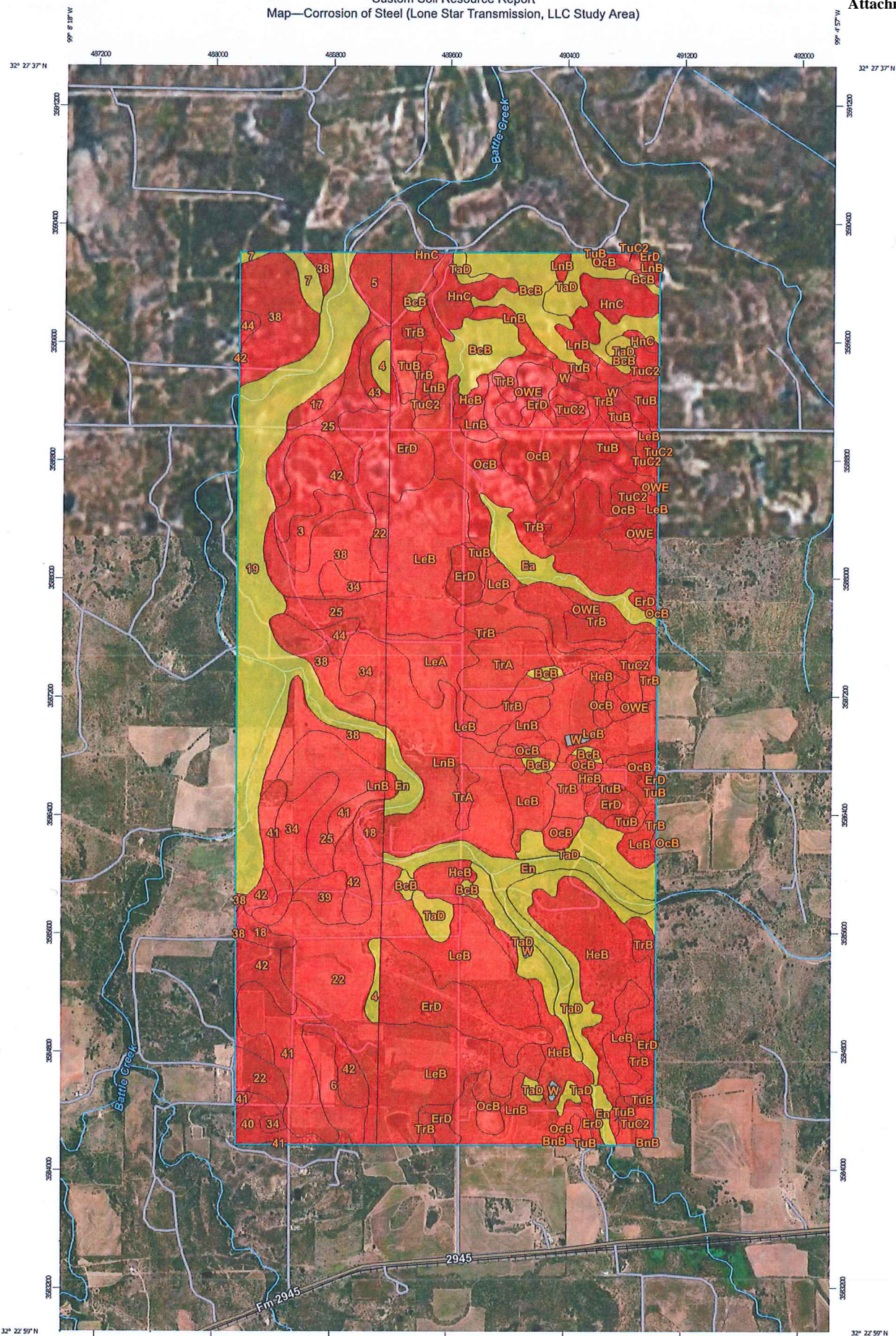

Map Scale: 1:24,000 if printed on B portrait (11" x 17") sheet.

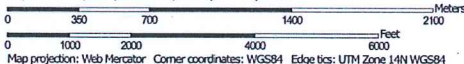

Map projection: Web Mercator Corner coordinates: WGS84 Edge tics: UTM Zone 14N WGS84

MAP LEGEND

- Area of Interest (AOI)  Area of Interest (AOI)
- Background  Aerial Photography
- Soils**
- Soil Rating Polygons**
 -  High
 -  Moderate
 -  Low
 -  Not rated or not available
- Soil Rating Lines**
 -  High
 -  Moderate
 -  Low
 -  Not rated or not available
- Soil Rating Points**
 -  High
 -  Moderate
 -  Low
 -  Not rated or not available
- Water Features**
 -  Streams and Canals
- Transportation**
 -  Rails
 -  Interstate Highways
 -  US Routes
 -  Major Roads
 -  Local Roads

MAP INFORMATION

The soil surveys that comprise your AOI were mapped at scales ranging from 1:20,000 to 1:24,000.

Please rely on the bar scale on each map sheet for map measurements.

Source of Map: Natural Resources Conservation Service
Web Soil Survey URL:
Coordinate System: Web Mercator (EPSG:3857)

Maps from the Web Soil Survey are based on the Web Mercator projection, which preserves direction and shape but distorts distance and area. A projection that preserves area, such as the Albers equal-area conic projection, should be used if more accurate calculations of distance or area are required.

This product is generated from the USDA-NRCS certified data as of the version date(s) listed below.

Soil Survey Area: Callahan County, Texas
Survey Area Data: Version 16, Sep 12, 2019

Soil Survey Area: Eastland County, Texas
Survey Area Data: Version 16, Sep 12, 2019

Your area of interest (AOI) includes more than one soil survey area. These survey areas may have been mapped at different scales, with a different land use in mind, at different times, or at different levels of detail. This may result in map unit symbols, soil properties, and interpretations that do not completely agree across soil survey area boundaries.

Soil map units are labeled (as space allows) for map scales 1:50,000 or larger.

Date(s) aerial images were photographed: Dec 31, 2009—Jul 24, 2017

The orthophoto or other base map on which the soil lines were compiled and digitized probably differs from the background

MAP LEGEND

MAP INFORMATION

imagery displayed on these maps. As a result, some minor shifting of map unit boundaries may be evident.

MAP LEGEND

Water	Blue
Soil	Green
...	...

MAP INFORMATION

imagery displayed on these maps. As a result, some minor shifting of map unit boundaries may be evident.

Custom Soil Resource Report

Table—Corrosion of Steel (Lone Star Transmission, LLC Study Area)

Map unit symbol	Map unit name	Rating	Acres in AOI	Percent of AOI
3	Bonti fine sandy loam, 1 to 3 percent slopes	High	24.2	0.6%
4	Bonti-Callahan association, 1 to 8 percent slopes, extremely stony	Moderate	18.4	0.4%
5	Callahan loam, 1 to 3 percent slopes	High	26.6	0.6%
6	Callahan loam, 2 to 5 percent slopes, moderately eroded	High	31.9	0.7%
7	Chaney loamy fine sand, 0 to 3 percent slopes	Moderate	15.0	0.3%
17	Frio clay loam, occasionally flooded	High	14.6	0.3%
18	Frio-Gageby association, frequently flooded	High	33.0	0.8%
19	Gageby loam, moist, 0 to 2 percent slopes, occasionally flooded	Moderate	304.6	7.1%
22	Leeray clay, 1 to 3 percent slopes	High	172.1	4.0%
25	Nukrum clay, 1 to 3 percent slopes	High	155.3	3.6%
34	Rowden clay loam, 0 to 3 percent slopes	High	94.6	2.2%
38	Sagerton loam, 1 to 3 percent slopes	High	238.9	5.6%
39	Speck clay loam, 1 to 3 percent slopes	High	21.6	0.5%
40	Speck-Throck association, gently undulating	High	25.4	0.6%
41	Throck clay loam, 2 to 5 percent slopes	High	120.3	2.8%
42	Throck-Callahan-Owens association, undulating	High	181.8	4.2%
43	Throck-Owens-Lueders association, hilly	High	15.5	0.4%
44	Throck-Speck association, undulating	High	15.8	0.4%
Subtotals for Soil Survey Area			1,509.5	35.2%
Totals for Area of Interest			4,287.7	100.0%

Custom Soil Resource Report

Map unit symbol	Map unit name	Rating	Acres in AOI	Percent of AOI
BcB	Bolar clay loam, 1 to 3 percent slopes	Moderate	153.4	3.6%
BnB	Bonti fine sandy loam, 1 to 3 percent slopes	High	2.8	0.1%
Ea	Elandco silty clay loam, 0 to 1 percent slopes, occasionally flooded	Moderate	47.2	1.1%
En	Elandco silty clay loam, frequently flooded	Moderate	112.8	2.6%
ErD	Bonti-Exray complex, 1 to 8 percent slopes, extremely stony	High	197.1	4.6%
HeB	Hensley loam, 1 to 3 percent slopes	High	204.3	4.8%
HnC	Hensley stony loam, 1 to 5 percent slopes	High	80.0	1.9%
LeA	Leeray clay, 0 to 1 percent slopes	High	43.8	1.0%
LeB	Leeray clay, 1 to 3 percent slopes	High	525.7	12.3%
LnB	Lindy loam, 1 to 3 percent slopes	High	307.4	7.2%
OcB	Owens clay, 1 to 5 percent slopes	High	201.9	4.7%
OWE	Owens clay, 5 to 30 percent slopes, extremely stony	High	64.9	1.5%
TaD	Palopinto very stony clay loam, 1 to 8 percent slopes, rubbly	Moderate	183.0	4.3%
TrA	Thurber clay loam, 0 to 1 percent slopes	High	63.6	1.5%
TrB	Thurber clay loam, 1 to 3 percent slopes	High	382.9	8.9%
TuB	Truce fine sandy loam, 1 to 3 percent slopes	High	106.5	2.5%
TuC2	Truce fine sandy loam, 1 to 5 percent slopes, eroded	High	94.6	2.2%
W	Water		6.4	0.2%
Subtotals for Soil Survey Area			2,778.2	64.8%
Totals for Area of Interest			4,287.7	100.0%

Rating Options—Corrosion of Steel (Lone Star Transmission, LLC Study Area)

Aggregation Method: Dominant Condition

Component Percent Cutoff: None Specified

Custom Soil Resource Report

Tie-break Rule: Higher

Custom Soil Resource Report

Soil Properties and Qualities

The Soil Properties and Qualities section includes various soil properties and qualities displayed as thematic maps with a summary table for the soil map units in the selected area of interest. A single value or rating for each map unit is generated by aggregating the interpretive ratings of individual map unit components. This aggregation process is defined for each property or quality.

Soil Qualities and Features

Soil qualities are behavior and performance attributes that are not directly measured, but are inferred from observations of dynamic conditions and from soil properties. Example soil qualities include natural drainage, and frost action. Soil features are attributes that are not directly part of the soil. Example soil features include slope and depth to restrictive layer. These features can greatly impact the use and management of the soil.

Depth to Any Soil Restrictive Layer (Lone Star Transmission, LLC Study Area)

A "restrictive layer" is a nearly continuous layer that has one or more physical, chemical, or thermal properties that significantly impede the movement of water and air through the soil or that restrict roots or otherwise provide an unfavorable root environment. Examples are bedrock, cemented layers, dense layers, and frozen layers.

This theme presents the depth to any type of restrictive layer that is described for each map unit. If more than one type of restrictive layer is described for an individual soil type, the depth to the shallowest one is presented. If no restrictive layer is described in a map unit, it is represented by the "> 200" depth class.

This attribute is actually recorded as three separate values in the database. A low value and a high value indicate the range of this attribute for the soil component. A "representative" value indicates the expected value of this attribute for the component. For this soil property, only the representative value is used.

MAP LEGEND

MAP INFORMATION

Imagery displayed on these maps. As a result, some minor shifting of map unit boundaries may be evident.

Custom Soil Resource Report

Table—Depth to Any Soil Restrictive Layer (Lone Star Transmission, LLC Study Area)

Map unit symbol	Map unit name	Rating (centimeters)	Acres in AOI	Percent of AOI
3	Bonti fine sandy loam, 1 to 3 percent slopes	86	24.2	0.6%
4	Bonti-Callahan association, 1 to 8 percent slopes, extremely stony	97	18.4	0.4%
5	Callahan loam, 1 to 3 percent slopes	91	26.6	0.6%
6	Callahan loam, 2 to 5 percent slopes, moderately eroded	86	31.9	0.7%
7	Chaney loamy fine sand, 0 to 3 percent slopes	>200	15.0	0.3%
17	Frio clay loam, occasionally flooded	>200	14.6	0.3%
18	Frio-Gageby association, frequently flooded	>200	33.0	0.8%
19	Gageby loam, moist, 0 to 2 percent slopes, occasionally flooded	>200	304.6	7.1%
22	Leeray clay, 1 to 3 percent slopes	>200	172.1	4.0%
25	Nukrum clay, 1 to 3 percent slopes	>200	155.3	3.6%
34	Rowden clay loam, 0 to 3 percent slopes	69	94.6	2.2%
38	Sagerton loam, 1 to 3 percent slopes	>200	238.9	5.6%
39	Speck clay loam, 1 to 3 percent slopes	46	21.6	0.5%
40	Speck-Throck association, gently undulating	46	25.4	0.6%
41	Throck clay loam, 2 to 5 percent slopes	76	120.3	2.8%
42	Throck-Callahan-Owens association, undulating	76	181.8	4.2%
43	Throck-Owens-Lueders association, hilly	76	15.5	0.4%
44	Throck-Speck association, undulating	76	15.8	0.4%
Subtotals for Soil Survey Area			1,509.5	35.2%
Totals for Area of Interest			4,287.7	100.0%

Custom Soil Resource Report

Map unit symbol	Map unit name	Rating (centimeters)	Acres in AOI	Percent of AOI
BcB	Bolar clay loam, 1 to 3 percent slopes	76	153.4	3.6%
BnB	Bonti fine sandy loam, 1 to 3 percent slopes	86	2.8	0.1%
Ea	Elandco silty clay loam, 0 to 1 percent slopes, occasionally flooded	>200	47.2	1.1%
En	Elandco silty clay loam, frequently flooded	>200	112.8	2.6%
ErD	Bonti-Exray complex, 1 to 8 percent slopes, extremely stony	76	197.1	4.6%
HeB	Hensley loam, 1 to 3 percent slopes	41	204.3	4.8%
HnC	Hensley stony loam, 1 to 5 percent slopes	41	80.0	1.9%
LeA	Leeray clay, 0 to 1 percent slopes	>200	43.8	1.0%
LeB	Leeray clay, 1 to 3 percent slopes	>200	525.7	12.3%
LnB	Lindy loam, 1 to 3 percent slopes	71	307.4	7.2%
OcB	Owens clay, 1 to 5 percent slopes	46	201.9	4.7%
OWE	Owens clay, 5 to 30 percent slopes, extremely stony	74	64.9	1.5%
TaD	Palopinto very stony clay loam, 1 to 8 percent slopes, rubbly	30	183.0	4.3%
TrA	Thurber clay loam, 0 to 1 percent slopes	>200	63.6	1.5%
TrB	Thurber clay loam, 1 to 3 percent slopes	>200	382.9	8.9%
TuB	Truce fine sandy loam, 1 to 3 percent slopes	142	106.5	2.5%
TuC2	Truce fine sandy loam, 1 to 5 percent slopes, eroded	107	94.6	2.2%
W	Water	>200	6.4	0.2%
Subtotals for Soil Survey Area			2,778.2	64.8%
Totals for Area of Interest			4,287.7	100.0%

Rating Options—Depth to Any Soil Restrictive Layer (Lone Star Transmission, LLC Study Area)

Units of Measure: centimeters

Aggregation Method: Dominant Component

Ademski, Thomas J (Tommy)

From: Gray, Natasha A CIV USARMY CESWF (USA) <Natasha.A.Gray@usace.army.mil>
Sent: Monday, May 4, 2020 1:14 PM
To: Ademski, Thomas J (Tommy)
Cc: Roeder, Katie O CIV (USA)
Subject: SWF-2020-00177, Road Runner Crossing Wind to Reata Station 345-kV Transmission Line

Dear Mr. Ademski:

Thank you for your letter received April 30, 2020, concerning a proposal by Lone Star Transmission, LLC to construct a new 345-kV electric transmission line to interconnect with proposed wind generation development located in Eastland County, Texas. The project has been assigned Project Number SWF-2020-00177, please include this number in all future correspondence concerning this project.

Ms. Katie Roeder has been assigned as the regulatory project manager for your request and will be evaluating it as expeditiously as possible.

You may be contacted for additional information about your request. For your information, please refer to the Fort Worth District Regulatory Division homepage at <http://www.swf.usace.army.mil/Missions/regulatory> and particularly guidance on submittals at <https://swf-apps.usace.army.mil/pubdata/environ/regulatory/introduction/submital.pdf> and mitigation at <https://www.swf.usace.army.mil/Missions/Regulatory/Permitting/Mitigation> that may help you supplement your current request or prepare future requests.

If you have any questions about the evaluation of your submittal or would like to request a copy of one of the documents referenced above, please refer to our website at <http://www.swf.usace.army.mil/Missions/Regulatory> or contact Ms. Katie Roeder at the address above, by telephone 817-886-1740, or by email Katie.O.Roeder@usace.army.mil, and refer to your assigned project number. Please note that it is unlawful to start work without a Department of the Army permit if one is required.

Please help the regulatory program improve its service by completing the survey on the following website:
http://corpsmapu.usace.army.mil/cm_apex/f?p=regulatory_survey

Brandon W. Mobley
Chief, Regulatory Division

Please do not mail hard copy documents to Regulatory staff or office, unless specifically requested. For further details on corresponding with us, please view our Electronic Application Submittals special public notice at:
<https://www.swf.usace.army.mil/Portals/47/docs/regulatory/publicnotices/2020/PublicNoticeElectronicApplications.pdf?ver=2019-11-21-123723-627>

USACE Fort Worth District Regulatory Division Website <http://www.swf.usace.army.mil/Missions/Regulatory.aspx>

Please assist us in better serving you by completing the survey at the following website:
http://corpsmapu.usace.army.mil/cm_apex/f?p=regulatory_survey

Ademski, Thomas J (Tommy)

From: Gray, Natasha A CIV USARMY CESWF (USA) <Natasha.A.Gray@usace.army.mil>
Sent: Monday, May 4, 2020 1:20 PM
To: Ademski, Thomas J (Tommy)
Subject: Electronic Submittal Process

CLASSIFICATION: UNCLASSIFIED

Mr. Ademski,

This e-mail is in reference to the electronic submittal procedures for the Fort Worth Regulatory Office. This applies to requests for jurisdictional determinations, preconstruction notifications, nationwide and individual permit applications, no permit required requests, mitigation plans, and scoping requests.

You may submit requests via e-mail in PDF format to CESWF-Permits@usace.army.mil (up to ~30MB total). If the file is very large, you can submit the request using SAFE DOD (<https://safe.apps.mil/>) by emailing CESWF-Permits@usace.army.mil and asking for a drop-off code.

Or you may send a CD to the Fort Worth District Regulatory Office at:
819 Taylor Street, Room 3A37,
P.O. Box 17300,
Fort Worth, TX 76102-0300.

NOTE: You are not permitted to submit new requests to individual project managers e-mail accounts. This is to ensure that a file number is assigned to the request. If the project has recently been given a file number, you are permitted to submit directly to the project manager.

The PDF must comply with the following requirements:

1. The first page of the PDF should be a complete "Preliminary Data Entry Sheet". If a project number is already associated with your project, this MUST be listed on the first page.
2. The request should follow the instructions that have been provided in the link below - Electronic Application Submittal Instructions.

<https://www.swf.usace.army.mil/Missions/Regulatory/Electronic-Submittal-Instructions/>

Failure to comply with these requirements could result in a delay in processing the request.

The Fort Worth e-mail is owned by the administrative staff in the Fort Worth District Regulatory Office. This inbox is not for general inquiries. The mailbox is checked daily and submissions are routed for assignment to a Project Manager as quickly as possible. You should receive an e-mail from the administrative staff in Fort Worth within 5 days of submitting the request. It will include the date received, project manager assignment, and a project number. If you don't hear from the administrative staff within 5 days, please contact the Fort Worth Regulatory office at (817) 886-1731. Submitters are welcome to request a delivery and/or read receipt notification with the email submission. The read receipt notification date will correspond to our clock start / "stamped in" date. In other words, should a requestor submit something via email after five o'clock p.m. on Friday or over the weekend and we open the email Monday morning, then our processing timeline starts Monday.

Please contact me via e-mail or at the number below if you have questions.

Sincerely,

Natasha Gray
Legal Instruments Examiner

Ademski, Thomas J (Tommy)

From: Roeder, Katie O CIV USARMY CESWF (USA) <Katie.O.Roeder@usace.army.mil>
Sent: Friday, May 15, 2020 11:42 AM
To: Ademski, Thomas J (Tommy)
Cc: Roeder, Katie O CIV USARMY CESWF (USA)
Subject: SWF-2020-00177, Road Runner Crossing

Dear Mr. Ademski:

I have reviewed your submittal for the Roadrunner Crossing to Reata Station Transmission line project (SWF-2020-00177). The USACE requires a permit for the discharge of dredged or fill material into Waters of the United States. The definition of waters of the United States includes navigable waters and tributaries to traditional navigable waters as well as wetlands, lakes and other aquatic resources. I am unable to tell by the information you provided whether or not there are waters of the United States (woUS) and if there are any impacts to them. Please provide a delineation of WoUS for the footprint of the project area. Please make sure to include photos where any aquatic resources are found and the design plan for the project.

Thank you,

Katie Roeder
Regulatory Specialist, Evaluation Branch Regulatory Division U.S. Army Corps of Engineers Ft. Worth District
819 Taylor Street
Fort Worth, Texas 76102-00300
Phone: 817-886-1740

Please do not mail hard copy documents to Regulatory staff or office, unless specifically requested. For further details on corresponding with us, please view our Electronic Application Submittals special public notice at:
<https://nam05.safelinks.protection.outlook.com/?url=https%3A%2F%2Fwww.swf.usace.army.mil%2FPortals%2F47%2Fdocs%2Fregulatory%2Fpublicnotices%2F2020%2FPublicNoticeElectronicApplications.pdf%3Fver%3D2019-11-21-123723-627&data=02%7C01%7Ctjademski%40burnsmcd.com%7C7a254bd82ab0458cbca608d7f8eef60d%7Cbfb9a2b6d994e78b3c795005d555c8b%7C0%7C1%7C637251577528607994&sd=ir86PYKW%2FZSvrVUtoM%2FQGnu%2BF1%2BCx1CGHEt%2BQzd10%3D&reserved=0>

USACE Fort Worth District Regulatory Division Website:
<https://nam05.safelinks.protection.outlook.com/?url=http%3A%2F%2Fwww.swf.usace.army.mil%2FMissions%2FRegulatory.aspx&data=02%7C01%7Ctjademski%40burnsmcd.com%7C7a254bd82ab0458cbca608d7f8eef60d%7Cbfb9a2b6d994e78b3c795005d555c8b%7C0%7C1%7C637251577528607994&sd=MuC%2B7D3UkQaXmQgQokPWNzKvcAc3xFOGQcaXGBG3i48%3D&reserved=0>

Please assist us in better serving you by completing the survey at the following website:
https://nam05.safelinks.protection.outlook.com/?url=http%3A%2F%2Fcorpsmapu.usace.army.mil%2Fcm_apex%2Ff%3Fp%3Dregulatory_survey&data=02%7C01%7Ctjademski%40burnsmcd.com%7C7a254bd82ab0458cbca608d7f8eef60d%7Cbfb9a2b6d994e78b3c795005d555c8b%7C0%7C1%7C637251577528607994&sd=Bmi%2BLhLRXJ2K%2FXaA6sG1yfcVCZZ5j0GjBimfjNRoFw%3D&reserved=0



TEXAS GENERAL LAND OFFICE
GEORGE P. BUSH, COMMISSIONER

April 30, 2020

Thomas J. Ademski
Burns McDonnell
8911 North Capital of Texas Highway, Building 3, Suite 3100
Austin, TX 78759-7285

Re: Request for Information
Lone Star Transmission, LLC Roadrunner Crossing Wind to Reata Station
345-kV Transmission Line Project

Dear Mr. Ademski:

On behalf of Commissioner Bush, I would like to thank you for your letter concerning the above-referenced project.

Using your map depicting the project's study area, it does not appear that the General Land Office will have any environmental issues or land use constraints at this time.

When a final route for this proposed project has been determined, please contact me and we can assess the route to determine if the project will cross any streambeds or Permanent School Fund (PSF) land that would require an easement from our agency.

In the interim, if you would like to speak to me further about this project, I can be reached by email at glenn.rosenbaum@glo.texas.gov or by phone at (512) 463-8180.

Again, thank you for your inquiry.

Sincerely,

A handwritten signature in black ink that reads "Glenn Rosenbaum".

Glenn Rosenbaum
Manager, Right-of-Way Department
Leasing Operations



May 21, 2020

Life's better outside.®

Commissioners

S. Reed Morian
Chairman
Houston

Arch "Beaver" Aplin, III
Vice-Chairman
Lake Jackson

James E. Abell
Kilgore

Oliver J. Bell
Cleveland

Anna B. Galo
Laredo

Jeffery D. Hildebrand
Houston

Jeanne W. Latimer
San Antonio

Robert L. "Bobby" Patton, Jr.
Fort Worth

Dick Scott
Wimberley

Lee M. Bass
Chairman-Emeritus
Fort Worth

T. Dan Friedkin
Chairman-Emeritus
Houston

Carter P. Smith
Executive Director

Mr. Thomas J. Ademski
Burns & McDonnell
8911 North Capital of Texas Highway, Building 3, Suite 3100
Austin, TX 78759

RE: Lone Star Transmission, LLC Roadrunner Crossing Wind to Reata Station
345-kilovolt (kV) Transmission Line Project

Dear Mr. Ademski:

Texas Parks and Wildlife Department (TPWD) has received the preliminary information request regarding the proposed transmission line project referenced above. TPWD staff has reviewed the information provided and offers the following comments concerning this project. For tracking purposes, please refer to TPWD project number 43789 in any return correspondence regarding this project.

Project Description

Lone Star Transmission, LLC (Lone Star) is proposing to design and construct a new 345-kV electric transmission line in the northwestern portion of Eastland County to interconnect a proposed wind generation development. The proposed transmission line would be constructed between the proposed Roadrunner Crossing Wind collector substation to the proposed Lone Star Reata Station. The proposed transmission line will be approximately 2.4 miles in length and require a right-of-way (ROW) between 100 to 150 feet in width. Burns & McDonnell is preparing an Environmental Assessment (EA) that will support Lone Star's application for a Certificate of Convenience and Necessity from the Public Utility Commission of Texas

Recommendation: TPWD recommends using existing facilities whenever possible. Where new construction is the only feasible option, TPWD recommends routing new transmission lines along existing roads, pipelines, transmission lines, or other utility ROW and easements to reduce habitat fragmentation. By utilizing existing utility corridors, county roads and highway ROWs, adverse impacts to fish and wildlife resources would be mitigated by avoiding and/or minimizing the impacts to undisturbed habitats. Please review the TPWD Recommendations for Electrical Transmission Line Design and Construction found on the Wildlife Habitat Assessment Program website.

Mr. Thomas J. Ademski
Page 2
May 21, 2020

General Construction Recommendations

TPWD would like to provide the following general construction recommendations to assist in project planning.

Recommendation: TPWD recommends the judicious use and placement of sediment control fence to exclude wildlife from the construction area. In many cases sediment control fence placement for the purposes of controlling erosion and protecting water quality can be modified minimally to also provide the benefit of excluding wildlife access to construction areas. The exclusion fence should be buried at least six inches and be at least 24 inches high. The exclusion fence should be maintained for the life of the project and only be removed after the construction is completed and the disturbed site has been revegetated with site-specific native species.

Construction personnel should be encouraged to examine the inside of the exclusion area daily to determine if any wildlife species have been trapped inside the area of impact and provide safe egress opportunities prior to initiation of construction activities. TPWD recommends that any open trenches or excavation areas be covered overnight and/or inspected every morning to ensure no wildlife species have been trapped. For open trenches and excavated pits, install escape ramps at an angle of less than 45 degrees (1:1) in areas left uncovered. Excavation areas should be inspected for trapped wildlife prior to refilling.

For soil stabilization and/or revegetation of disturbed areas, TPWD recommends erosion and seed/mulch stabilization materials that avoid entanglement hazards to snakes and other wildlife species. TPWD recommends the use of no-till drilling, hydromulching and/or hydroseeding due to a reduced risk to wildlife.

Because the mesh found in many erosion control blankets or mats pose an entanglement hazard to wildlife, TPWD recommends avoiding the use of plastic mesh matting. If erosion control blankets or mats containing netting must be used, the netting should be loosely woven, natural fiber material where the mesh design allows the threads to move, therefore allowing expansion of the mesh openings.

Federal Laws

Migratory Bird Treaty Act

The Migratory Bird Treaty Act (MBTA) prohibits direct and affirmative purposeful actions that reduce migratory birds, their eggs, or their nests, by killing or capturing, to human control, except when specifically authorized by U.S. Fish and Wildlife

Mr. Thomas J. Ademski
Page 3
May 21, 2020

Service (USFWS). This protection applies to most native bird species, including ground nesting species.

Recommendation: TPWD recommends excluding vegetation clearing activities during the general bird nesting season, March 15 through September 15, to avoid adverse impacts to birds. If clearing vegetation during the migratory bird nesting season is unavoidable, TPWD recommends surveying the area proposed for disturbance for active nests (nests with eggs or young). Nest surveys should take place within 5 days of scheduled clearing in order to maximize the detection of active nests. Any vegetation (trees, shrubs, and grasses) or bare ground where occupied nests are located should not be disturbed and a vegetation buffer area of no less than 150-feet in diameter should remain around the nest until all young have fledged.

State Laws

Parks and Wildlife Code – Chapter 64, Birds

TPW Code Section 64.002, regarding protection of nongame birds, provides that no person may catch, kill, injure, pursue, or possess a bird that is not a game bird. TPW Code Section 64.003, regarding destroying nests or eggs, provides that, no person may destroy or take the nests, eggs, or young and any wild game bird, wild bird, or wild fowl. TPW Code Chapter 64 does not allow for incidental take and therefore is more restrictive than the MBTA.

Recommendation: Please review the *Federal Law: Migratory Bird Treaty Act* section above for recommendations as they are also applicable for Chapter 64 of the Parks and Wildlife Code compliance.

Parks and Wildlife Code, Section 68.015

TPW Code regulates state-listed threatened and endangered animal species. The capture, trap, take, or killing of state-listed threatened and endangered animal species is unlawful unless expressly authorized under a permit issued by USFWS or TPWD. A copy of *TPWD Guidelines for Protection of State-Listed Species*, which includes a list of penalties for take of species, can be found on the TPWD website. State-listed species may only be handled by persons with appropriate authorization from the TPWD Wildlife Permits Office. For more information, please contact the Wildlife Permits Office at (512) 389-4647.

Texas horned lizard (*Phrynosoma cornutum*) – State-listed Threatened

The Texas horned lizard can be found in open, arid and semi-arid regions with sparse vegetation, including grass, cactus, scattered brush or scrubby trees. If present in the project area, the Texas horned lizard could be impacted by ground

Mr. Thomas J. Ademski
Page 4
May 21, 2020

disturbing construction activities. Horned lizards may hibernate on-site in the loose soils a few inches below ground during the cool months from September/October to March/April. Construction in these areas could harm hibernating lizards. Horned lizards are active above ground when temperatures exceed 75 degrees Fahrenheit. If horned lizards (nesting, gravid females, newborn young, lethargic from cool temperatures or hibernation) cannot move away from noise and approaching construction equipment in time, they could be affected by construction activities. Based on a review of aerial imagery and Ecological Mapping Systems data suitable habitat for the Texas horned lizard may be present in the study area.

Recommendation: TPWD recommends avoiding disturbance of the Texas horned lizard, its burrows, and colonies of its primary food source, the harvester ant (*Pogonomyrmex* sp.), during clearing and construction. TPWD recommends a permitted biological monitor be present during construction to relocate Texas horned lizards, if found. If the presence of a biological monitor during construction is not feasible, Texas horned lizards observed during construction should be allowed to safely leave the site.

A mixture of cover, food sources, and open ground is important to the Texas horned lizard and harvester ant. Disturbed areas within suitable habitat for the Texas horned lizard should be re-vegetated with site-specific native, patchy vegetation rather than sod-forming grasses.

Species of Concern/Special Features

In addition to state and federally protected species, TPWD tracks species considered to be Species of Greatest Conservation Need (SGCN) that, due to limited distributions and/or declining populations, face threat of extirpation or extinction but currently lack the legal protections given to threatened or endangered species. Special landscape features, natural plant communities, and SGCN are rare resources for which TPWD actively promotes conservation, and TPWD considers it important to minimize impacts to such resources to reduce the likelihood of endangerment and preclude the need to list SGCN as threatened or endangered in the future. These species and communities are tracked in the Texas Natural Diversity Database (TXNDD). The most current and accurate TXNDD data can be requested from the TXNDD website.

No records of rare and protected species have been documented within 10 miles of the study area. Please note that the absence of TXNDD information in an area does not imply that a species is absent from that area. Given the small proportion of public versus private land in Texas, the TXNDD does not include a representative inventory of rare resources in the state. Although it is based on the best data available to TPWD regarding rare and protected species, data from the TXNDD does not provide a definitive statement as to the presence, absence or condition of special species, natural communities, or other significant features within your

Mr. Thomas J. Ademski
Page 5
May 21, 2020

project area. These data are not inclusive and cannot be used as presence/absence data. This information cannot be substituted for on-the-ground surveys.

Recommendation: Please review the TPWD county list for Eastland County, as rare and protected species could be present, depending upon habitat availability. These lists, which were recently updated on April 13, 2020, are available on the Rare, Threatened, and Endangered Species of Texas website. TPWD recommends including a discussion and evaluation of potential impacts to SGCN (in addition to state listed and federally listed species) in the EA for this project. The USFWS should be contacted for species occurrence data, guidance, permitting, survey protocols, and mitigation for federally listed species. For USFWS threatened and endangered species lists, please see the USFWS Information for Planning and Consultation website.

Determining the actual presence of a species in an area depends on many variables including daily and seasonal activity cycles, environmental activity cues, preferred habitat, transiency and population density (both wildlife and human). The absence of a species can only be established with repeated negative observations and consideration of all factors contributing to the lack of detectable presence. If encountered during construction, measures should be taken to avoid impacting wildlife.

Monarch Conservation Plan

Significant declines in the population of migrating monarch butterflies (*Danaus plexippus*) have led to widespread concern about this species and the long-term persistence of the North American monarch migration. Augmenting larval feeding and adult nectaring opportunities is part of an international conservation effort for the monarch.

Recommendation: For disturbed sites within the monarch migration corridor, TPWD recommends revegetation efforts include planting or seeding native milkweed (*Asclepias* spp) and nectar plants as funding and seed availability allow.

Vegetation

Based on Ecological Mapping Systems data, the following vegetation types are found in the study area:

- Barren
- Cross Timbers: Oak / Hardwood Slope Forest
- Cross Timbers: Post Oak Woodland
- Cross Timbers: Savanna Grassland
- Edwards Plateau: Oak – Hardwood Motte and Woodland

Mr. Thomas J. Ademski
Page 6
May 21, 2020

- Edwards Plateau: Live Oak Motte and Woodland
- Edwards Plateau: Savanna Grassland
- High Plains: Floodplain Deciduous Shrubland
- High Plains: Floodplain Hardwood / Juniper Forest
- High Plains: Floodplain Hardwood Forest
- High Plains: Floodplain Herbaceous Vegetation
- High Plains: Floodplain Juniper Shrubland
- High Plains: Floodplain Live Oak Forest
- High Plains: Riparian Deciduous Shrubland
- High Plains: Riparian Hardwood Forest
- High Plains: Riparian Herbaceous Vegetation
- High Plains: Riparian Juniper Shrubland
- High Plains: Riparian Live Oak Forest
- Native Invasive: Deciduous Woodland
- Native Invasive: Mesquite Shrubland
- Rolling Plains: Breaks Deciduous Shrubland
- Rolling Plains: Mixedgrass Prairie
- Open Water
- Row Crops
- Urban High Intensity
- Urban Low Intensity

Additional information about Ecological Mapping Systems data, including a link to download shapefiles, can be found on the TPWD Landscape Ecology Program website.

Conservation Easements

A conservation easement is a legal agreement between a landowner and a land trust or governmental agency that permanently limits uses of the land (including future fragmentation) to protect and conserve the land's natural values such as fertile soils, mature trees, and wildlife habitat. Lands with conservation easements protect existing wildlife habitat from future fragmentation and therefore have greater environmental integrity than comparable lands without conservation easements. Potential fragmentation of wildlife habitat from transmission line construction on properties where conservation agreements serve to protect the state's natural resources now and in the future is of concern to TPWD.

Recommendation: TPWD recommends properties protected by conservation easements be identified in the constraints analysis and avoided during development of alternative routes. Data sources for the location of these properties include, but are not limited to, online databases such as the Protected Areas Data Portal and the National Conservation Easement Database, as well

Mr. Thomas J. Ademski
Page 7
May 21, 2020

as available county records. If properties protected by conservation easements would be affected, TPWD recommends the length of routes through these properties be included in any accounting of alternative route impacts.

TPWD strives to respond to requests for project review within a 45-day comment period. Responses may be delayed due to workload and lack of staff. Failure to meet the 45-day review timeframe does not constitute a concurrence from TPWD that the proposed project will not adversely impact fish and wildlife resources.

I appreciate the opportunity to provide preliminary input on potential impacts related to this project and I look forward to reviewing the EA. Please contact me at (806)761-4936 or Richard.Hanson@tpwd.texas.gov if you have any questions.

Sincerely,

Rick Hanson

Rick Hanson
Wildlife Habitat Assessment Program
Wildlife Division
RH: 43789

cc: Rochelle Robles, Public Utility Commission

May 20, 2020

Thomas Ademski
Burns and McDonnell
8911 North Capital of Texas Highway
Bldg 4, Suite 4260
Austin, TX 78759

Re: Project review: Proposed Roadrunner Wind Crossing to Reata Station; Eastland County
(PUC: 202012291)

Dear Mr. Ademski,

Thank you for your correspondence describing the above referenced project. This letter serves as comment on the proposed undertaking from the State Historic Preservation Officer, the Executive Director of the Texas Historical Commission.

The review staff, led by Tiffany Osburn, has completed its review. According to our maps, the proposed transmission line project will cross an area that has never been surveyed by a professional archeologist and is likely to contain additional historic and archeological resources.

We recommend consulting with a professional archeologist early in your route selection process to allow avoidance of recorded archeological resources. Your archeologist should also identify areas high probability areas (HPAs) for further investigation and submit their scope of work for our concurrence once the route is selected. You can obtain lists of most professional archeologists in Texas on-line at www.rpanet.org or <http://www.counciloftexasarcheologists.org>. Please note that other professional archeologists meeting the qualifying standards may be used; see these standards at http://www.cr.nps.gov/local-law/arch_stnds_9.htm.

Thank you for your assistance in this state review process, and for your efforts to preserve the irreplaceable heritage of Texas. If you have any questions concerning our review or if we can be of further assistance, please contact Tiffany Osburn at tiffany.osburn@thc.texas.gov.

Sincerely,



for
Mark Wolfe, State Historic Preservation Officer

MW/to

COUNTY of EASTLAND



REX FIELDS

County Judge
100 W. Main, Ste. 203
Eastland, Texas 76448
254-629-1263
FAX - 254-629-6090

Linda Whetstone
County Court
Coordinator

Cherre Livingston
Secretary / Indigent Health
Care Coordinator

28 April 2020

Thomas J. Ademski
Project Manager

Burns McDonnell
8911 N. Capital of Texas Hwy
Bldg 3, Ste 3100
Austin TX 78759
512-872-7130

RE: Roadrunner Crossing Wind to Reata Station project for Eastland County

Dear Mr. Ademski,

As you requested in your letter of 24 April 2020 to me, I have reviewed the locations that you supplied for construction of a new collector substation named Roadrunner Crossing Wind and another project known as Lone Star Reata Station with an interconnected electric transmission line. The projects are located in the unincorporated areas of Eastland County, specifically CR 126 at CR 125 and CR 126 at CR128. My review methodology for the projects utilized the Flood Hazard Boundary Maps for the unincorporated area of Eastland County Texas, Community Panel Number 480793 0001B along with Pictometry mapping software.

In addition to the above referenced resources, I used the statements and plan for the projects as supplied by you.

As Eastland County Judge and Flood Plain Administrator for the unincorporated area of Eastland County, it is my opinion that these projects as proposed are not located in a flood hazard zone area and if constructed to the proposed design should not adversely affect flood plain management in Eastland County Texas. In addition, this proposed project does not appear to violate the County's airport zoning ordinance. The proposed project does not require any further zoning approval by Eastland County TX. The project will however, have to comply with any and all applicable federal and state regulations.

If you need any further information from my office, please contact me.

Sincerely,

A handwritten signature in blue ink, appearing to read "Rex Fields".

Rex Fields
Eastland County Judge
100 West Main, Ste 203
Eastland Texas, 76448
254-629-1263, ecjudge@eastlandcountytexas.com

**Reata Station to Roadrunner Crossing Wind
345kV Transmission Line
PUC Docket No. 50910
Figure 2-2**

THE FOLLOWING PAGE IS IN AN OVERSIZED MAP AND CAN BE VIEWED
IN CENTRAL RECORDS OR THE PUC INTERCHANGE BY DOWNLOADING
THE NATIVE FILE (ZIP) FOR THIS APPLICATION IN DOCKET NO. 50910

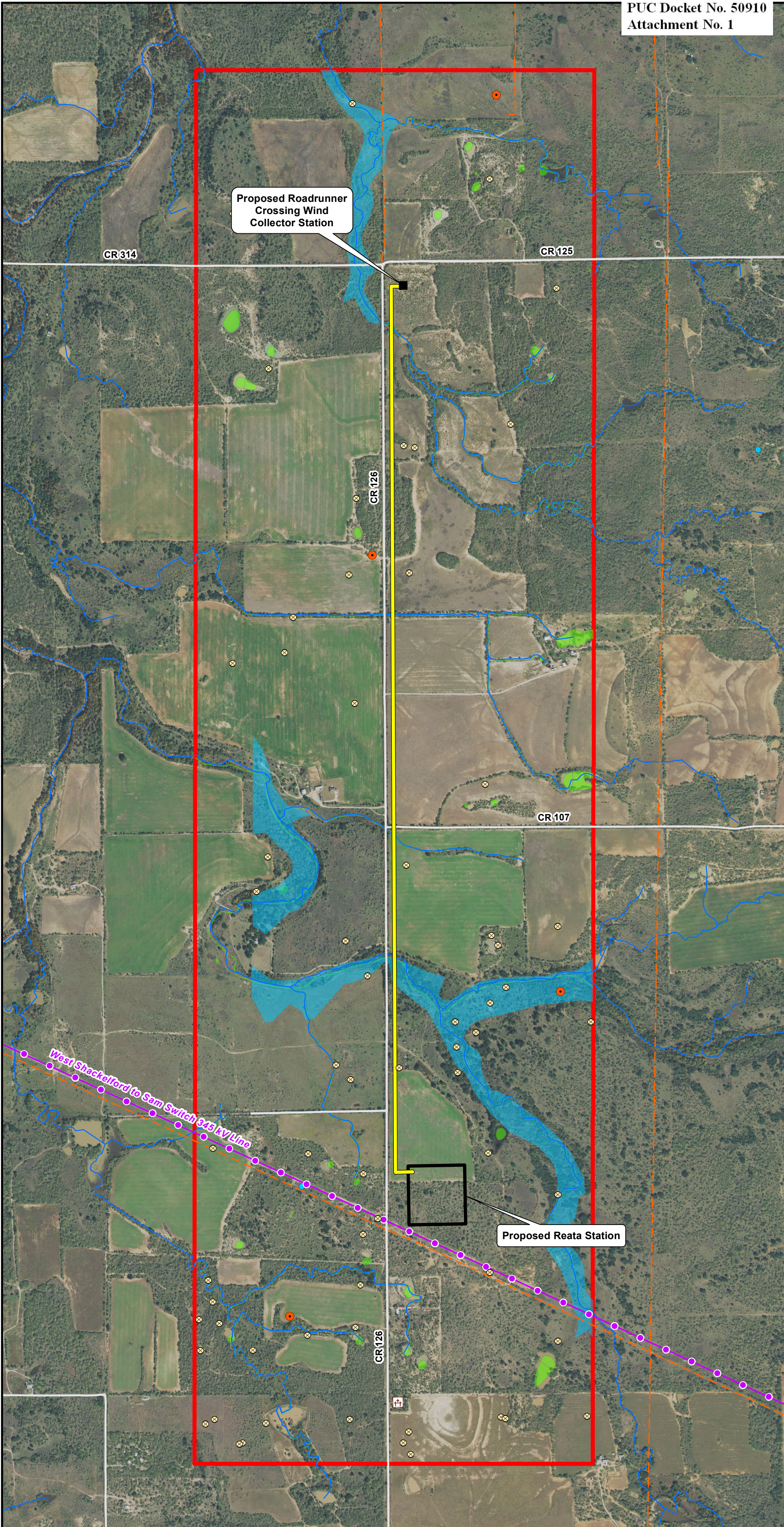

Path: \\dalsrv\data\Projects\ESP\ONE STAR TRANSMISSION\Roadrunner 345kV\Geospatial\DataFiles\ArcDocs\RX2RS_Figure_2_2_Constraints.mxd gacox 5/21/2020

- Project Endpoint
- Consensus Route
- Study Area
- Existing Transmission Line
- Pipeline
- Creek / Stream
- Water Well
- Active Oil, Gas, or Injection Well
- Abandoned, Dry, Plugged, or Permitted Well
- Cemetery
- 100-Year Floodplain
- Wetland

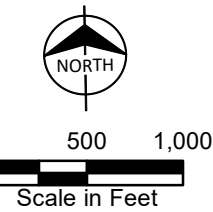

Figure 2-2
Consensus Route in Relation to
Environmental and Land Use Constraints
Reata Station to Roadrunner Crossing Wind
345 kV Transmission Line
Lone Star Transmission
Eastland County, Texas



CREATE AMAZING.

Burns & McDonnell
8911 North Capital of Texas Highway, Suite 3100
Austin, TX 78759
O 512-872-7130
F 512-872-7127
www.burnsmcd.com

LANDOWNER CONSENSUS ROUTE AGREEMENT

THE STATE OF TEXAS §
 §
COUNTY OF EASTLAND §

I (or we), TEB Land & Cattle, LP, hereby acknowledge and confirm that I (or we) own the following property, pursuant to Deed dated June 10, 2014, recorded July 8, 2014 as Instrument No. 2014-2056 (WD), Official Public Records, Eastland County, Texas; and dated June 10, 2014, recorded June 13, 2014 as Instrument No. 2014-1120 (WD), Official Public Records, Callahan County, Texas, each as applicable:

Tract 1 (Palmer Place):

340 acres, more or less, described in two tracts in Eastland County, Texas, to-wit

First Tract 240 acres, more or less, being all of TE&L:Co. Survey 3172, Abstract 510, less the North 80 acres of said Survey heretofore sold to J. A. Yeager by deed recorded in Volume 67, Page 300, Eastland County, Texas

Second Tract: 100 acres, more or less, off of the North side of TE&L Co. Survey 3177, Abstract 515: Beginning at the N.W. corner of said Survey; Thence East 1344 varas to N.E. corner of said Survey; Thence South 420 varas to E.B.L. of said Survey; Thence West 1344 varas to W.B.L. of said Survey; Thence North 420 varas to beginning.

Tract 2 (J. L. Pippen Place):

160 acres, more or less, and being known and described as the South 1/2 of Survey No. 3167, as surveyed for and patented to the Texas Emigration and Land Company by Patent No. 333, Volume 23, dated November 22, 1858, Abstract No. 492, containing 160 acres of land more or less, Eastland and Callahan Counties, Texas, and described by metes and bounds as follows:

Beginning at the original Southeast corner of said Survey No. 3167; Thence North 672 varas to a corner; Thence West 1344 varas to a corner in the West line of said Survey No. 3167; Thence South 672 varas to its original Southwest corner for the SW corner of this Survey;

Thence East 1344 varas to the Place of Beginning and being the same land conveyed to J. L. Pippen by W. C. Pippen by deed dated January 2, 1940 recorded in Volume 355, Page 450, Deed Records of Eastland County, Texas, and Volume 169, Page 99, Deed Records, Callahan County, Texas.

Tract 3 (Pippen Place):

574.5 acres, more or less, described in four tracts in Eastland and Callahan Counties, Texas, to-wit:

First Tract: 160 acres, more or less, being North 1/2 of TE&L Co. Survey 3167, Eastland County Abstract 1092, Callahan County Abstract 492

Second Tract: 40 acres, more or less, being the North 1/2 of the NW 1/4 of TE&L Co. Survey 3170, Eastland County Abstract 508;

Third Tract: 240 acres, more or less, being the South 3/4 of TE&L Co. Survey 3170, Eastland County Abstract 508; and

Fourth Tract: 160 acres, more or less, being the West 1/2 of TE&L Co. Survey 3171, Eastland County Abstract 509.

SAVE AND EXCEPT the following two tracts:

5.5 acres conveyed to Fred Hernandez, Jr. by Warranty Deed of record in Volume 1420, Page 215 of the Official Public Records of Eastland County, Texas.

20 acres conveyed to James Harper et ux by Warranty Deed of record in Eastland County Clerk's Document No. 2012-001597 of the Official Public Records of Eastland County, Texas.

I (or we) acknowledge that Lone Star Transmission, LLC ("Lone Star") proposes to file an Application to Amend Its Certificate of Convenience and Necessity ("CCN") with the Public Utility Commission of Texas ("PUC") to construct and operate a 345-kilovolt (kV) transmission line that will connect Lone Star's proposed Reata Station, to be located on the east side of County Road 126 and adjacent to Lone Star's existing 345 kV line, to Roadrunner Crossing Wind's proposed collector station to be located in the southeast corner of CR 126 and CR 125. Lone Star will propose that the PUC approve a Consensus Route that is agreed to by each owner of property that is directly affected by the route (Consensus Landowner), as shown on the map included with this Agreement as "Exhibit A." Lone Star will include this Agreement with its Application to demonstrate the Consensus Landowners' agreement.

I (or we) and Lone Star agree that the PUCT should approve the Consensus Route that will be presented for consideration by the PUCT in Lone Star's Application. I (or we) acknowledge that the new 345-kV transmission line, if approved, will be installed on my property described above and depicted in the attached sketch labeled Exhibit A. I (or we) further acknowledge this consent does not convey the necessary land rights needed to construct and operate the transmission.

I (or we) hereby give my (or our) written consent to Lone Star's Consensus Route. By executing this Agreement, I (or we) represent that I (or we) are authorized to sign this Agreement on behalf of the person or entity represented and signifies support of this Agreement.

TEB Land & Cattle, L P.
a Texas limited partnership

By: Truman Bacon Cattle, LLC, a Texas limited liability company
Its: General Partner

By: Nancy A. Bacon, the Managing Member
Nancy A. Bacon, the Managing Member

Address:

P.O. Box 588
Cisco, TX 76437



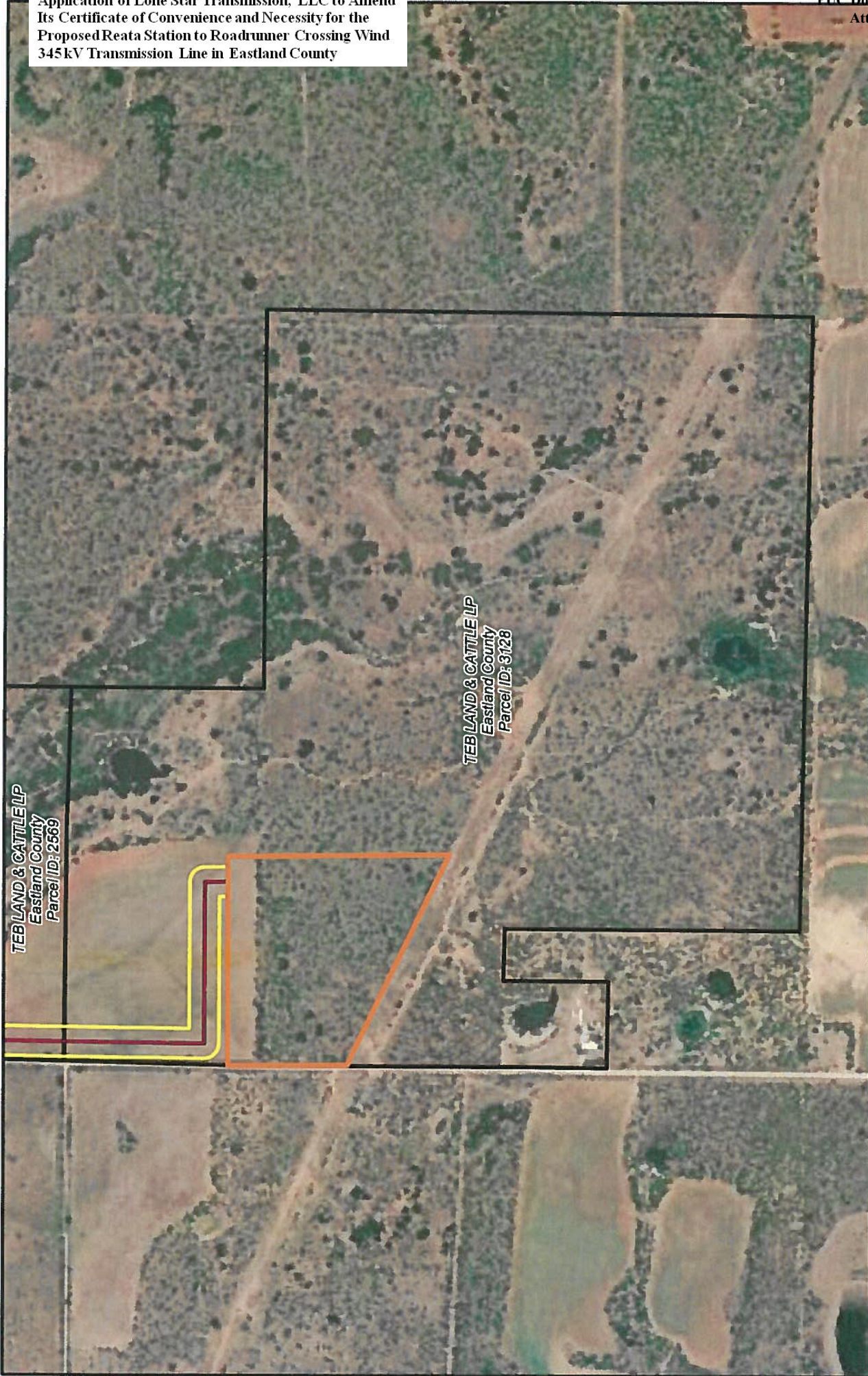

Date: June 12, 2020

EXHIBIT A

[SEE ATTACHED]



Lone Star Transmission
Proposed Roadrunner Crossing Wind 345 kV Transmission
Landowner: **TEBLAND & CATTLE LP** Parcel ID: 3128
June 5, 2020

-  Lone Star's Proposed Reata Station
-  Proposed Transmission Route
-  100' - 150' Transmission Easement
-  Parcel



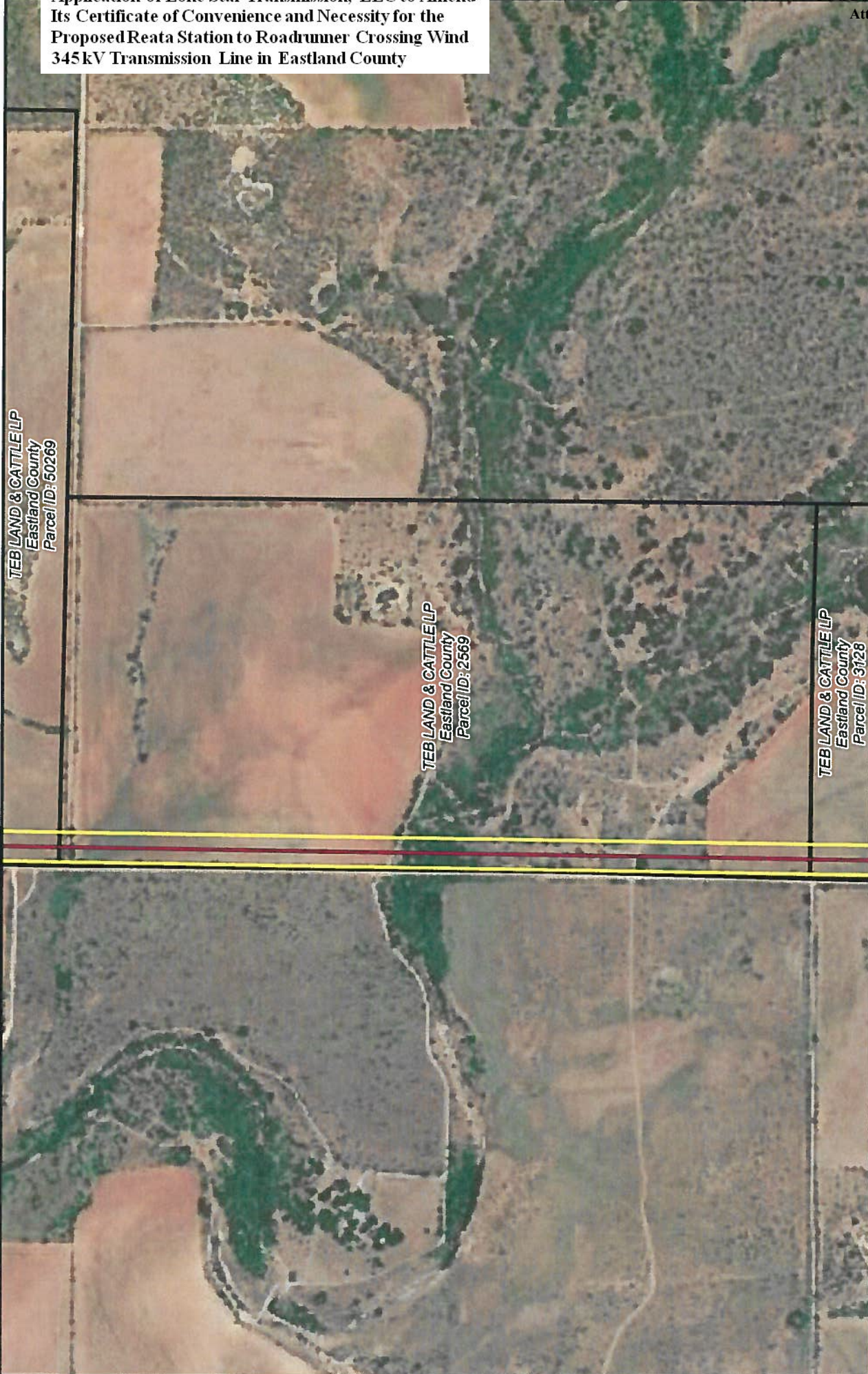

TEB LAND & CATTLE LP
Eastland County
Parcel ID: 50269

TEB LAND & CATTLE LP
Eastland County
Parcel ID: 2569

TEB LAND & CATTLE LP
Eastland County
Parcel ID: 3128

Lone Star Transmission
Proposed Roadrunner Crossing Wind 345 kV Transmission
Landowner: TEB LAND & CATTLE LP Parcel ID: 2569
June 5, 2020

0 500 1,000 2,000 Feet

Proposed Transmission Route
100' - 150' Transmission Easement
Parcel



Lone Star Transmission
Proposed Roadrunner Crossing Wind 345 kV Transmission
Landowner: TEB LAND & CATTLE LP Parcel ID: 50269
June 5, 2020
870
435
1,740
Feet

Proposed Transmission Route
100' - 150' Transmission Easement
Parcel

LANDOWNER CONSENSUS ROUTE AGREEMENT

THE STATE OF TEXAS §
 §
COUNTY OF EASTLAND §

I (or we), G&R Capital Properties, LLC Eastland County Series, a Texas series limited liability company, hereby acknowledge and confirm that I (or we) own the following property, pursuant to Deed dated June 5, 2014, recorded June 30, 2014 as Instrument No. 2014-001958 (WD), Deed Records, Eastland County, Texas:

BEING of a 401.682 acres tract of land out of T.E.&L. Co. Survey No. 3172, Abstract No. 510, and T.E.&L. Co. Survey, Abstract No. 511, Eastland County Texas; being the same tract as called 400 acres of land described in Quit Claim Deeds, recorded in Volume 1649, Page 230, and Volume 1651 ,Page 276, Official Public Records of Eastland County, Texas; and being further described by metes and bounds- as follows:

BEGINNING at a set 1/2" iron rod in the east line of said 400 acres tract and at the northeast corner of said T.E.&L. Co. Survey No. 3172, Abstract No. 510, for the beginning corner of this tract, whence the Southeast corner of said 400 acres tract bears South 00° 01' 12", East 951.00 feet. THENCE South 00° 01' 12" East 951.00. feet to a 4" steel post for the Southeast corner of this tract. THENCE 89° 47' 33" West 3662.61 feet to a set spike in County Road No. 126 (gravel) and in the West line of said Survey No. 3172 for the southwest corner of this tract. THENCE North 4667.84 feet with said Road to a set spike in the intersection of said Road and County Road No. 125 (gravel) and at the Northwest corner of said Survey No. 3173 for the Northwest corner of this tract. THENCE North 89° 25' 57" East 3764.21 feet with said County Road No. 125 to a set spike, at the Northeast corner of said Survey No. 3173 for the Northeast corner of this tract. THENCE South 00° 23' 18" East at 24.82 feet past a set 1/2" iron rod in the South right of way of said County Road No. 125 and in all 1884.38 feet to a set 1/2" iron rod for a corner of this tract. THENCE South 03° 28' 52" West 1886.53 feet to the PLACE OF BEGINNING.

I (or we) acknowledge that Lone Star Transmission, LLC (“Lone Star”) proposes to file an Application to Amend Its Certificate of Convenience and Necessity (“CCN”) with the Public Utility Commission of Texas (“PUC”) to construct and operate a 345-kilovolt (kV) transmission line that will connect Lone Star’s proposed Reata Station, to be located on the east side of County Road 126 and adjacent to Lone Star’s existing 345 kV line, to Roadrunner Crossing Wind’s proposed collector station to be located

in the southeast corner of CR 126 and CR 125. Lone Star will propose that the PUCT approve a Consensus Route that is agreed to by each owner of property that is directly affected by the route (Consensus Landowner), as shown on the map included with this Agreement as "Exhibit A." Lone Star will include this Agreement with its Application to demonstrate the Consensus Landowners' agreement.

I (or we) and Lone Star agree that the PUCT should approve the Consensus Route that will be presented for consideration by the PUCT in Lone Star's Application. I (or we) acknowledge that the new 345-kV transmission line, if approved, will be installed on my property described above and depicted in the attached sketch labeled Exhibit A. I (or we) further acknowledge this consent does not convey the necessary land rights needed to construct and operate the transmission.

I (or we) hereby give my (or our) written consent to Lone Star's Consensus Route. By executing this Agreement, I (or we) represent that I (or we) are authorized to sign this Agreement on behalf of the person or entity represented and signifies support of this Agreement.

G&R Capital Properties, LLC

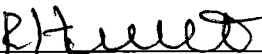
By: 
Rafael E. Haros, a Managing Member

By: 
Gerardo Haros, a Managing Member

Address: 807 Yellowstone Drive
Mansfield, TX 76063

Date: June 22 2020

EXHIBIT A

[SEE ATTACHED]

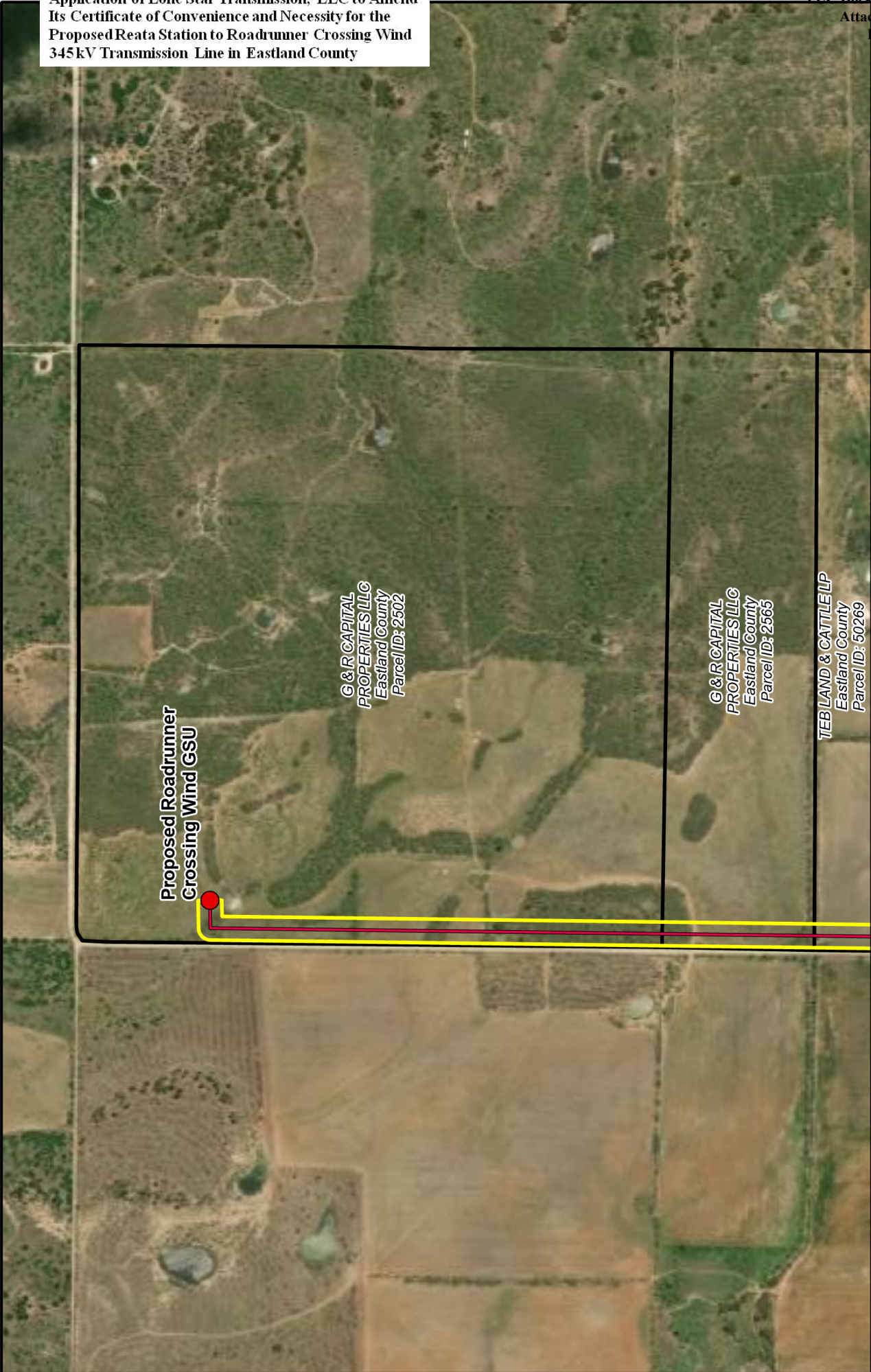

Lone Star Transmission
Proposed Roadrunner Crossing Wind 345 kV Transmission
Landowner: G&R CAPITAL PROPERTIES, LLC Parcel ID: 2502 & 2565
June 22, 2020

- Proposed Generator Step-Up Station
- Proposed Transmission Route
- 100' - 150' Transmission Easement
- Parcel



**ERCOT STANDARD GENERATION
INTERCONNECTION AGREEMENT**

Between

Roadrunner Crossing Wind Farm, LLC

and

Lone Star Transmission, LLC

for

Roadrunner Crossing Wind Farm, LLC

Date: April 17, 2020

TABLE OF CONTENTS

ERCOT STANDARD GENERATION INTERCONNECTION AGREEMENT..... 3

EXHIBIT ‘A’ - TERMS AND CONDITIONS OF THE ERCOT STANDARD GENERATION INTERCONNECTION AGREEMENT
 5

ARTICLE 1. DEFINITIONS..... 5

ARTICLE 2. TERMINATION..... 6

ARTICLE 3. REGULATORY FILINGS..... 7

*ARTICLE 4. INTERCONNECTION FACILITIES ENGINEERING, PROCUREMENT, AND
 CONSTRUCTION..... 7*

ARTICLE 5. FACILITIES AND EQUIPMENT..... 10

ARTICLE 6. OPERATION AND MAINTENANCE..... 12

ARTICLE 7. DATA REQUIREMENTS..... 13

ARTICLE 8. PERFORMANCE OBLIGATION..... 14

ARTICLE 9. INSURANCE..... 15

ARTICLE 10. MISCELLANEOUS..... 16

EXHIBIT ‘B’ - TIME SCHEDULE 22

EXHIBIT ‘C’ - INTERCONNECTION DETAILS 24

Plant Name..... 24

Point of Interconnection Location..... 24

Delivery Voltage..... 24

Number and Size of Generating Units..... 24

Type of Generating Unit..... 24

Metering and Telemetry Equipment..... 24

Generator Interconnection Facilities..... 25

TSP Interconnection Facilities..... 26

Communications Facilities..... 28

System Protection Equipment..... 29

Inputs to Telemetry Equipment..... 31

Supplemental Terms and Conditions..... 31

Special Operating Conditions..... 36

Cost Estimate Differences..... 36

EXHIBIT ‘D’ - NOTICE AND EFT INFORMATION..... 40

EXHIBIT ‘E’ - SECURITY ARRANGEMENT DETAILS 42

ERCOT STANDARD GENERATION INTERCONNECTION AGREEMENT

This Standard Generation Interconnection Agreement is made and entered into this 17th day of April, 2020 (“Effective Date”), between **Lone Star Transmission, LLC** (“Transmission Service Provider”) and **Roadrunner Crossing Wind Farm, LLC** (“Generator”), hereinafter individually referred to as “Party,” and collectively referred to as “Parties.” In consideration of the mutual covenants and agreements herein contained, the Parties hereto agree as follows:

Transmission Service Provider is a public utility that owns and operates facilities for the transmission and distribution of electricity. Generator will own, operate, and maintain the Plant (as defined in Exhibit “A”). Pursuant to the terms and conditions of this Agreement, Transmission Service Provider shall interconnect Generator’s Plant with Transmission Service Provider’s System consistent with the Interconnection Study Agreement executed between the Parties on April 3, 2018 and pursuant to the ERCOT generation interconnection request #19INR0117.

This Agreement applies only to the Plant and the Parties’ interconnection facilities as identified in Exhibit “C”.

This Agreement shall become effective as of the Effective Date, subject to Governmental Authority approval, if required, and shall continue in full force and effect until terminated in accordance with Exhibit “A”.

This Agreement will be subject to the following, all of which are incorporated herein:

- A. The “Terms and Conditions of the ERCOT Standard Generation Interconnection Agreement” attached hereto as Exhibit “A”;
- B. The ERCOT Requirements (unless expressly stated herein, where the ERCOT Requirements are in conflict with this Agreement, the ERCOT Requirements shall prevail);
- C. The PUCT Rules (where the PUCT Rules are in conflict with this Agreement, the PUCT Rules shall prevail);
- D. The Time Schedule attached hereto as Exhibit “B”;
- E. The Interconnection Details attached hereto as Exhibit “C”;
- F. The notice requirements attached hereto as Exhibit “D”; and
- G. The Security Arrangement Details attached hereto as Exhibit “E”.

**Application of Lone Star Transmission, LLC to Amend
Its Certificate of Convenience and Necessity for the
Proposed Reata Station to Roadrunner Crossing Wind
345 kV Transmission Line in Eastland County**

IN WITNESS WHEREOF, the Parties have executed this Agreement in duplicate originals, each of which shall constitute and be an original effective Agreement between the Parties.

Lone Star Transmission, LLC

Roadrunner Crossing Wind Farm, LLC

By: 

Audrea Williams

Title: President

Date: April 17, 2020

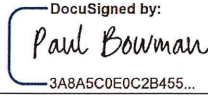
By: 
3A8A5C0E0C2B455...

Senior Vice President

Title: _____

Date: 4/13/2020

Exhibit "A"

Terms and Conditions of the ERCOT Standard Generation Interconnection Agreement

ARTICLE 1. DEFINITIONS

Capitalized terms shall have the meanings as set forth below, except as otherwise specified in the Agreement:

1.1 "CCN" shall mean a Certificate of Convenience and Necessity issued by the PUCT.

1.2 "Commercial Operation" shall mean the date on which Generator declares that the construction of the Plant has been substantially completed, Trial Operation of the Plant has been completed, and the Plant is ready for dispatch.

1.3 "Control Area" shall have the meaning ascribed thereto in PUCT Rule 25.5 or its successor.

1.4 "ERCOT" shall mean the Electric Reliability Council of Texas, Inc.

1.5 "ERCOT Requirements" means the ERCOT Nodal Operating Guides, ERCOT Generation Interconnection Procedures, and ERCOT Nodal Protocols, as well as any other documents adopted by ERCOT relating to the interconnection and operation of generators and transmission systems in ERCOT as amended from time to time, and any successors thereto. Any requirement in the foregoing documents imposed upon generation entities or generation facilities shall become the responsibility of the Generator, and any requirements imposed on transmission providers or transmission facilities shall become the responsibility of the TSP.

1.6 "Facilities Study" shall have the meaning as described in PUCT Rule 25.198(d) or its successor.

1.7 "GIF" shall mean Generator's interconnection facilities as described in Exhibit "C."

1.8 "Good Utility Practice" shall have the meaning described in PUCT Rule 25.5 or its successor.

1.9 "Governmental Authority(ies)" shall mean any federal, state, local or municipal body having jurisdiction over a Party.

1.10 "In-Service Date" shall be the date, as reflected in Exhibit "B," that the TIF will be ready to connect to the GIF.

1.11 "Interconnection Study Agreement" shall mean an agreement executed by the Parties relating to the performance of interconnection studies.

1.12 "Plant" shall mean the electric generation facility owned and operated by the Generator, as specified in Exhibit "C."

- 1.13 “Point of Interconnection” shall mean the location(s) where the GIF connects to the TIF as negotiated and defined by the Parties and as shown on Exhibit “C” of this Agreement.
- 1.14 “PUCT” shall mean the Public Utility Commission of Texas.
- 1.15 “PUCT Rules” shall mean the Substantive Rules of the PUCT.
- 1.16 “Reasonable Efforts” shall mean the use of Good Utility Practice and the exercise of due diligence pursuant to PUCT Rule 25.198(e) or its successor.
- 1.17 “System Protection Equipment” shall mean those facilities located within the TIF and the GIF as described in Section 5.6 and Exhibit “C.”
- 1.18 “System Security Study” shall have the meaning as described in PUCT Rule 25.198(c) or its successor.
- 1.19 “TCOS” shall mean the TSP’s transmission cost of service as allowed by the applicable Governmental Authority.
- 1.20 “TIF” shall mean the TSP’s interconnection facilities as described in Exhibit “C” to this Agreement.
- 1.21 “Trial Operation” shall mean the process by which the Generator is engaged in on-site test operations and commissioning of the Plant prior to Commercial Operation.
- 1.22 “TSP” shall mean the Transmission Service Provider.
- 1.23 “TSP System” shall mean the electric transmission facilities, including the TIF, and all associated equipment and facilities owned and/or operated by the TSP.

ARTICLE 2. TERMINATION

- 2.1 Termination Procedures. This Agreement may be terminated as follows:
- A. the Generator may terminate this Agreement after giving the TSP thirty (30) days’ advance written notice; or
 - B. the TSP may terminate this Agreement (subject to Governmental Authority approval, if required) on written notice to the Generator if the Generator’s Plant has not achieved Commercial Operation within one (1) year after the scheduled Commercial Operation date reflected in Exhibit “B”; or
 - C. either Party may terminate this Agreement in accordance with Section 10.6.
- 2.2 Termination Costs. If a Party elects to terminate the Agreement pursuant to Section 2.1 above, then Generator shall promptly pay, or reimburse TSP for, all costs that are the responsibility of the Generator under this Agreement and incurred, or committed to be incurred, by TSP as of the date of the notice of termination. In the event of termination by a Party, each

Party shall use Reasonable Efforts to mitigate the damages and charges that it may incur as a consequence of such termination.

2.3 Disconnection. Upon termination of this Agreement, the Parties will disconnect the GIF from the TIF. The provisions of Section 2.2 and Section 2.3 shall survive termination of the Agreement.

ARTICLE 3. REGULATORY FILINGS

3.1 Filing. The TSP shall file this executed Agreement with the PUCT. Each Party will cooperate reasonably with each other in connection with such filings. Any portion of this Agreement asserted by Generator to contain competitively sensitive commercial or financial information shall be filed by the TSP identified as “confidential” under seal stating, for the TSP’s showing of good cause, that Generator asserts such information is confidential information and has requested such filing under seal. If requested by the TSP, Generator shall provide the TSP, in writing, with the Generator’s basis for asserting that the information referred to in this Section 3.1 is competitively sensitive information, and the TSP may disclose such writing to the appropriate Governmental Authority.

3.2 Regulatory Approvals. Unless exempt, the TSP shall timely request from ERCOT and any other Governmental Authority all regulatory approvals necessary for it to carry out its responsibilities under this Agreement. Such approvals shall include any CCN required for the construction of the TIF.

ARTICLE 4. INTERCONNECTION FACILITIES ENGINEERING, PROCUREMENT, AND CONSTRUCTION

4.1 Options. The Generator shall select one of the following options (subsection A or subsection B) and include the selected option in Exhibit “B” for completion of the TIF:

A. The TSP shall design, procure, and construct the TIF, using Reasonable Efforts to complete the TIF by the In-Service Date reflected in Exhibit “B.” The TSP will utilize its own resources and will contract for additional resources, as reasonably necessary, to meet the In-Service Date. Such resources shall include, as the TSP believes is reasonable, use of other contractors, other equipment suppliers, other material suppliers, additional contract personnel, additional payments to contractors for expedited work, and premiums paid to equipment and material suppliers for expedited delivery. The TSP shall not be required to undertake any initiative which is inconsistent with its standard safety practices, its material and equipment specifications, its design criteria and construction procedures, its labor agreements, applicable laws and regulations, and ERCOT Requirements. In the event the TSP reasonably expects that it will not be able to complete the TIF by the In-Service Date, the TSP will promptly provide written notice to the Generator and will undertake Reasonable Efforts to meet the earliest date thereafter.

B. (i) The TSP shall design, procure, and construct the TIF by the In-Service Date reflected in Exhibit “B”. The Parties acknowledge that the In-Service Date was either agreed

upon through good faith negotiations or designated by the Generator upon failure of the Parties to agree. In the process of negotiating the In-Service Date, Generator will request a date upon which it reasonably expects it will be ready to begin use of the TIF and upon which it reasonably expects to begin doing so. Any date designated by the Generator shall in no event be less than fifteen months from the date that all conditions of Sections 4.2 and 4.3 have been satisfied. The designated In-Service Date will be extended day for day for each day that ERCOT refuses to grant clearances to install equipment. If the TSP fails to complete the TIF by the In-Service Date reflected in Exhibit "B", the TSP shall pay the Generator liquidated damages in accordance with this Section 4.1.B.

(ii) The Parties agree that actual damages to the Generator, in the event the TIF are not completed by the In-Service Date, may include Generator's fixed operation and maintenance costs and lost opportunity costs. Such actual damages are uncertain and impossible to determine at this time. The Parties agree that, because of such uncertainty, any liquidated damages paid by the TSP to the Generator shall be an amount equal to $\frac{1}{2}$ of 1% of the actual cost of the TIF, per day. However, in no event shall the total liquidated damages exceed 20% of the actual cost of the TIF. The Parties agree that such liquidated damages are less than the Generator's actual damages. The Parties agree that the foregoing payments will be made by the TSP to the Generator as just compensation for the damages caused to the Generator, which actual damages are uncertain and impossible to determine at this time, and as reasonable liquidated damages, but not as a penalty or a method to secure performance of this Agreement.

(iii) The TSP shall apply to have the full costs of the TIF included in TCOS. If the PUCT issues a final, appealable order excluding from TCOS any portion of the TIF costs, including higher contractor and vendor costs due to liquidated damage provisions in those contracts and insurance costs to cover liquidated damages, which costs may have been reasonably incurred but which the PUCT finds should not be recovered through TCOS, the Generator shall reimburse the TSP for such costs in an amount not to exceed the difference between the TSP's estimate of the cost of the TIF under section 4.1.A and the TSP's estimate of the cost of the TIF under Section 4.1.B as reflected in Exhibit "C". Such costs shall be estimated using Good Utility Practice.

(iv) No liquidated damages shall be paid to Generator if the Generator is not ready to commence use of the TIF for the delivery of power to the Plant for Trial Operation or export of power from the Plant on the In-Service Date, unless the Generator would have been able to commence use of the TIF for the delivery of power to the Plant for Trial Operation or export of power from the Plant but for TSP's delay.

(v) If the In-Service Date has been designated by the Generator upon a failure of the Parties to agree on the In-Service Date, the TSP may, at its option, require the Generator to subcontract with the TSP for all or part of the design, procurement and construction of the TIF in accordance with the TSP's standard subcontractor agreements. In such event, the TSP shall be subject to the payment of liquidated damages to the Generator only if the In-Service Date is not met solely due to the TSP's failure to complete the portion of the TIF for which the TSP has retained responsibility. It is the intent of this subsection to give the TSP full control of the contents and quality of the TIF. To the extent the Generator acts as a subcontractor to the TSP, the following will apply: 1) The Generator shall engineer, procure equipment, and construct the

TIF (or portions thereof) using Good Utility Practice and using standards and specifications provided in advance by the TSP; 2) In its engineering, procurement and construction of the TIF, the Generator shall comply with all requirements of law to which the TSP would be subject in the engineering, procurement or construction of the TIF; 3) The TSP shall review and approve the engineering design, acceptance tests of equipment, and the construction of the TIF; 4) The TSP shall have the right to approve, and accept for operation, the TIF in accordance with the standards and specifications provided in advance by the TSP, such approval and acceptance shall not be unreasonably withheld, conditioned, or delayed; 5) Should any phase of the engineering, equipment procurement, or construction of the TIF, including selection of subcontractors, not meet the standards and specifications provided by the TSP, and therefore be deemed unacceptable, then the Generator shall be obligated to remedy that portion of the TIF or selection of subcontractors that is deemed unacceptable, the TSP's approval of the Generator's selection of subcontractors will not be unreasonably withheld, conditioned or delayed; and 6) Once the TIF is accepted for operation by the TSP, then the TSP shall reimburse the Generator for the reasonable and necessary costs incurred by the Generator to complete the TIF, not to exceed the amount specified in the subcontract. Such reimbursement shall be made within thirty (30) days after receipt of the invoice, unless otherwise agreed to by the Parties.

4.2 Equipment Procurement. If responsibility for construction of the TIF is borne by the TSP, then the TSP shall commence design of the TIF and procure necessary equipment within a reasonable time after all of the following conditions are satisfied:

A. The TSP has completed the Facilities Study pursuant to the Interconnection Study Agreement;

B. The TSP has received written authorization to proceed with design and procurement from the Generator by the date specified in Exhibit "B"; and

C. The Generator has provided security to the TSP in accordance with Section 8.3 by the dates specified in Exhibit "B".

4.3 Construction Commencement. The TSP shall commence construction of the TIF as soon as practicable after the following additional conditions are satisfied:

A. Approval of the appropriate Governmental Authority has been obtained for any facilities requiring regulatory approval;

B. Necessary real property rights, if any, have been obtained;

C. The TSP has received written authorization to proceed with construction from the Generator by the date specified in Exhibit "B"; and

D. The Generator has provided security to the TSP in accordance with Section 8.3 by the dates specified in Exhibit "B."

4.4 Work Progress. The Parties will keep each other advised periodically as to the progress of their respective design, procurement, and construction efforts. If, at any time, the Generator becomes aware that the completion of the TIF will not be required until after the specified In-

Service Date, the Generator will promptly provide written notice to the TSP of a new, later In-Service Date.

4.5 Conditions Precedent Delay. To the extent this Agreement incorporates a specified In-Service Date and the Generator fails to satisfy conditions precedent under Sections 4.2 and 4.3, the Parties agree to negotiate in good faith to establish a new schedule for completion of the TIF, and the In-Service Date shall be extended accordingly.

ARTICLE 5. FACILITIES AND EQUIPMENT

5.1 Information Exchange. The Parties shall exchange information and mutually agree upon the design and compatibility of the Parties' interconnection facilities. The Parties shall work diligently and in good faith to make any necessary design changes to ensure compatibility of the GIF to the TSP System.

5.2 GIF Construction. Generator agrees to cause the GIF to be designed and constructed in accordance with Good Utility Practice, ERCOT Requirements, and the National Electrical Safety Code in effect at the time of construction. Within one-hundred and twenty (120) days after Commercial Operation, unless the Parties agree on another mutually acceptable deadline, the Generator shall deliver to the TSP the following "as-built" drawings, information, and documents for the GIF: a one-line diagram, a site plan showing the Plant and the GIF, plan and elevation drawings showing the layout of the GIF, a relay functional diagram, relaying AC and DC schematic wiring diagrams, and relay settings for all facilities associated with the Generator's main-power transformers, the facilities connecting the Generator to the main power transformers and the GIF, and the impedances (determined by factory tests) for the associated main power transformers and the generators and, if applicable, the impedance of any transmission voltage lines that are part of the GIF.

5.3 TIF Construction. The TSP agrees to cause the TIF to be designed and constructed in accordance with Good Utility Practice, ERCOT Requirements, and the National Electrical Safety Code in effect at the time of construction.

5.4 Equipment Changes. For facilities not described in Exhibit "C," if either Party makes equipment changes to the Plant, the GIF, the TIF, or the TSP System which it reasonably believes will affect the operation or performance of the other Party's interconnection facilities, such Party agrees to notify the other Party, in writing, of such changes. Such changes shall be made in accordance with ERCOT Requirements and coordinated between the Parties.

5.5 Metering, Telemetry and Communications Requirements.

A. Metering and telemetry of data will be accomplished in accordance with ERCOT Requirements. The specific metering, telemetry and communications equipment to be installed and data to be telemetered are described in Exhibit "C."

B. At the Point of Interconnection, the metering and telemetry equipment shall be owned by the TSP. However, the TSP shall provide the Generator with metering and telemetry values in accordance with ERCOT Requirements.

C. A minimum set of inputs to the telemetry equipment are specified in Exhibit "C." Additional sets of inputs may be subsequently mutually agreed upon.

D. The TSP will notify the Generator at least five (5) business days in advance of any planned maintenance, inspection, testing, or calibration of the metering equipment, unless otherwise agreed to in writing. The Generator, or its designated representative, shall have the right to be present for these activities and to receive copies of any documents related to the procedures and results.

E. Prior to the connection of the GIF to the TIF, acceptance tests will be performed by the owning Party to ensure the proper functioning of all metering, telemetry, and communications equipment associated with the Point of Interconnection and both Parties' interconnection facilities, and to verify the accuracy of data being received by the TSP, ERCOT, and the Generator. All acceptance tests will be performed consistent with ERCOT Requirements.

F. The TSP shall, in accordance with Good Utility Practice and ERCOT Requirements, specify communications facilities, including those necessary to transmit data from the metering equipment to the TSP, that are necessary for the effective operation of the Plant and the GIF with the TSP System. Such communication facilities shall be included in Exhibit "C." The Generator shall make arrangements to procure and shall be responsible for the costs of such facilities.

G. Any changes to the meters, telemetry equipment, voltage transformers, current transformers, and associated panels, hardware, conduit, and cable, that will affect the data being received by a Party must be mutually agreed to by the Parties.

H. Each Party will promptly advise the other Party if it detects or is otherwise aware of any metering, telemetry, or communications equipment errors or malfunctions that require the attention and/or correction by the other Party. The Party owning such equipment shall correct such error or malfunction as soon as reasonably practical in accordance with ERCOT Requirements.

5.6 System Protection and Other Controls Requirements.

A. Each Party's facilities shall be designed to isolate any fault, or to correct or isolate any abnormality, that would negatively affect the other Party's system or other entities connected to the TSP System.

B. The Generator shall be responsible for protection of its facilities and the Plant consistent with ERCOT Requirements.

C. Each Party's protective relay design shall incorporate the necessary test switches to perform the tests required in Section 5.6.F. The required test switches will be placed such that they allow operation of lockout relays while preventing breaker failure schemes from operating and causing unnecessary breaker operations and tripping the Generator's units.

D. Recording equipment shall be installed to analyze all system disturbances in accordance with ERCOT Requirements.

E. Each Party will test, operate, and maintain System Protection Equipment in accordance with ERCOT Requirements. Each Party will provide reasonable notice to the other Party of any testing of its System Protection Equipment allowing such other Party the opportunity to have representatives present during testing of its System Protection Equipment.

F. Prior to the In-Service Date, and again prior to Commercial Operation, each Party or its agent shall perform a complete calibration test and functional trip test of the System Protection Equipment. At intervals suggested by Good Utility Practice or at intervals described in the ERCOT Requirements (if so defined therein), and following any apparent malfunction of the System Protection Equipment, each Party shall perform both calibration and functional trip tests of its System Protection Equipment. These tests do not require the tripping of any in-service generation unit. These tests do, however, require that all protective relays and lockout contacts be activated.

5.7 No Annexation. Any and all equipment placed on the premises of a Party shall be and remain the property of the Party providing such equipment regardless of the mode and manner of annexation or attachment to real property, unless otherwise mutually agreed by the Parties.

ARTICLE 6. OPERATION AND MAINTENANCE

6.1 Operation and Maintenance of Interconnection Facilities. The Parties agree to operate and maintain their systems in accordance with Good Utility Practice, National Electrical Safety Code, the ERCOT Requirements, PUCT Rules, and all applicable laws and regulations. In addition, Generator agrees to operate and maintain its system in accordance with the National Electrical Safety Code. Subject to any necessary ERCOT approval, each Party shall provide necessary equipment outages to allow the other Party to perform periodic maintenance, repair, or replacement of its facilities. Such outages shall be scheduled at mutually agreeable times, unless conditions exist which a Party believes, in accordance with Good Utility Practice, may endanger persons or property. No changes will be made in the normal operation of the Point of Interconnection without the mutual agreement of the Parties, except as otherwise provided herein. All testing of the Plant that affects the operation of the Point of Interconnection shall be coordinated between the TSP, ERCOT, and the Generator and will be conducted in accordance with ERCOT Requirements.

6.2 Control Area. The Point of Interconnection shall be located within the ERCOT Control Area. The Control Area within ERCOT is a single Control Area, with ERCOT assuming authority as the Control Area operator in accordance with ERCOT Requirements.

6.3 Land Rights and Easements. Terms and conditions addressing the rights of the TSP and the Generator regarding any facilities located on the other Party's property shall be addressed in a separate, duly executed, and recorded easement agreement between the Parties. Prior to Commercial Operation, the Parties will mutually agree upon procedures to govern access to each other's property as necessary for the Parties to fulfill their obligations hereunder.

6.4 Service Interruption. The Parties recognize that the interruption of service provisions of

the PUCT Rules give TSP the right to disconnect the TSP System from the Plant under the conditions specified therein. The Generator will promptly disconnect the Plant from the TSP System when required by and in accordance with the PUCT Rules and ERCOT Requirements.

6.5 Switching and Clearance.

A. Any switching or clearances needed on the TIF or the GIF will be done in accordance with ERCOT Requirements.

B. Any switching and clearance procedure necessary to comply with Good Utility Practice or ERCOT Requirements that may have specific application to the Plant shall be addressed in Exhibit "C."

6.6 Start-Up and Synchronization. Consistent with ERCOT Requirements and the Parties' mutually acceptable procedure, the Generator is responsible for the proper synchronization of the Plant to the TSP System.

6.7 Routine Operational Communications. On a timely basis, the Parties shall exchange all information necessary to comply with ERCOT Requirements.

6.8 Blackstart Operations. If the Plant is capable of blackstart operations, Generator will coordinate individual Plant start-up procedures consistent with ERCOT Requirements. Any blackstart operations shall be conducted in accordance with the blackstart criteria included in the ERCOT Requirements and the TSP blackstart plan on file with ERCOT. Notwithstanding this section, the Generator is not required to have blackstart capability by virtue of this Agreement. If the Generator will have blackstart capability, then Generator shall provide and maintain an emergency communication system that will interface with the TSP during a blackstart condition.

6.9 Power System Stabilizers. The Generator shall procure, install, maintain, and operate power system stabilizers if required to meet ERCOT Requirements and as described in Exhibit "C."

ARTICLE 7. DATA REQUIREMENTS

7.1 Data Acquisition. The acquisition of data to realistically simulate the electrical behavior of system components is a fundamental requirement for the development of a reliable interconnected transmission system. Therefore, the TSP and the Generator shall be required to submit specific information regarding the electrical characteristics of their respective facilities to each other as described below in accordance with ERCOT Requirements.

7.2 Initial Data Submission by TSP. The initial data submission by the TSP shall occur prior to Trial Operation and shall include transmission system data necessary to allow the Generator to select equipment and meet any system protection and stability requirements.

7.3 Initial Data Submission by Generator. The initial data submission by the Generator, including manufacturer data, shall occur no later than ninety (90) days prior to the Trial Operation and shall include a completed copy of the following forms contained in the ERCOT Generation Interconnection Procedure: (1) Plant Description/Data; and (2) Generation Stability

Data. It shall also include any additional data provided to ERCOT for the System Security Study. Data in the initial submissions shall be the most current Plant design or expected performance data. Data submitted for stability models shall be compatible with ERCOT standard models. If there is no compatible model, the Generator will work with an ERCOT-designated consultant to develop and supply a standard model and associated data.

7.4 Data Supplementation. Prior to Commercial Operation, the Parties shall supplement their initial data submissions with any and all “as-built” Plant data or “as-tested” performance data which differs from the initial submissions or, alternatively, written confirmation that no such differences exist. Subsequent to Commercial Operation, the Generator shall provide the TSP any data changes due to equipment replacement, repair, or adjustment. The TSP shall provide the Generator any data changes due to equipment replacement, repair, or adjustment in the directly connected substation or any adjacent TSP-owned substation that may affect the GIF equipment ratings, protection or operating requirements. The Parties shall provide such data no later than thirty (30) days after the date of the actual change in equipment characteristics. Also, the Parties shall provide to each other a copy of any additional data later required by ERCOT concerning these facilities.

7.5 Data Exchange. Each Party shall furnish to the other Party real-time and forecasted data as required by ERCOT Requirements. The Parties will cooperate with one another in the analysis of disturbances to either the Plant or the TSP’s System by gathering and providing access to any information relating to any disturbance, including information from oscillography, protective relay targets, breaker operations, and sequence of events records.

ARTICLE 8. PERFORMANCE OBLIGATION

8.1 Generator’s Cost Responsibility. The Generator will acquire, construct, operate, test, maintain, and own the Plant and the GIF at its sole expense. In addition, the Generator may be required to make a contribution in aid of construction in the amount set out in and for the facilities described in Exhibit “C,” if any, in accordance with PUCT Rules.

8.2 TSP’s Cost Responsibility. The TSP will acquire, own, operate, test, and maintain the TIF at its sole expense, subject to the provisions of Section 4.1.B and the contribution in aid of construction provisions of Section 8.1 of this Agreement.

8.3 Financial Security Arrangements. The TSP may require the Generator to pay a reasonable deposit or provide another means of security, to cover the costs of planning, licensing, procuring equipment and materials, and constructing the TIF. The required security arrangements are specified in Exhibit “E.” Within five (5) business days after TSP has received notice from the Generator that the Plant has achieved Commercial Operation, and TSP has verified the same, the TSP shall return the deposit(s) or security to the Generator. However, the TSP may retain an amount to cover the incremental difference between the TSP’s actual out of pocket costs associated with the choice of Section 4.1.B over Section 4.1.A, pending a final PUCT Order as contemplated in Section 4.1.B(iii). If the Plant has not achieved Commercial Operation within one (1) year after the scheduled Commercial Operation date identified in Exhibit “B” or if the Generator terminates this Agreement in accordance with Section 2.1 and the TIF are not required, the TSP may, subject to the provisions of Section 2.2, retain as much of the

deposit or security as is required to cover the costs it incurred in planning, licensing, procuring equipment and materials, and constructing the TIF. If a cash deposit is made pursuant to Exhibit "E," any repayment of such cash deposit shall include interest at a rate applicable to customer deposits as established from time to time by the PUCT or other Governmental Authority.

ARTICLE 9. INSURANCE

9.1 Each Party shall, at its own expense, maintain in force throughout the period of this Agreement, and until released by the other Party the following minimum insurance coverages, with insurers authorized to do business in Texas:

A. Employers Liability and Worker's Compensation Insurance providing statutory benefits in accordance with the laws and regulations of the State of Texas. The minimum limits for the Employer's Liability insurance shall be One Million Dollars (\$1,000,000) each accident bodily injury by accident, One Million Dollars (\$1,000,000) each employee bodily injury by disease, and One Million Dollars (\$1,000,000) policy limit bodily injury by disease.

B. Commercial General Liability Insurance including premises and operations, personal injury, broad form property damage, broad form blanket contractual liability coverage (including coverage for the contractual indemnification) products and completed operations coverage, coverage for explosion, collapse and underground hazards, independent contractors coverage, coverage for pollution to the extent normally available and punitive damages to the extent normally available and a cross liability endorsement, with minimum limits of One Million Dollars (\$1,000,000) per occurrence/One Million Dollars (\$1,000,000) aggregate combined single limit for personal injury, bodily injury, including death and property damage.

C. Comprehensive Automobile Liability Insurance for coverage of owned, non-owned, and hired vehicles, trailers, or semi-trailers designed for travel on public roads, with a minimum combined single limit of One Million Dollars (\$1,000,000) per occurrence for bodily injury, including death, and property damage.

D. Excess Public Liability Insurance over and above the Employer's Liability, Commercial General Liability, and Comprehensive Automobile Liability Insurance coverage, with a minimum combined single limit of Twenty Million Dollars (\$20,000,000) per occurrence/Twenty Million Dollars (\$20,000,000) aggregate.

E. The Commercial General Liability Insurance, Comprehensive Automobile Liability Insurance, and Excess Public Liability Insurance policies shall name the other Party, its parent, associated and affiliated companies, and their respective directors, officers, agents, servants, and employees ("Other Party Group") as additional insured. All policies shall contain provisions whereby the insurers waive all rights of subrogation in accordance with the provisions of this Agreement against the Other Party Group. Each Party shall provide thirty (30) days' advance written notice to Other Party Group prior to cancellation or any material change in coverage or condition.

F. The Commercial General Liability Insurance, Comprehensive Automobile Liability Insurance, and Excess Public Liability Insurance policies shall contain provisions that

specify that the policies are primary and shall apply to such extent without consideration for other policies separately carried and shall state that each insured is provided coverage as though a separate policy had been issued to each, except the insurer's liability shall not be increased beyond the amount for which the insurer would have been liable had only one insured been covered. Each Party shall be responsible for its respective deductibles or retentions.

G. The Commercial General Liability Insurance, Comprehensive Automobile Liability Insurance, and Excess Public Liability Insurance policies, if written on a Claims First Made basis, shall be maintained in full force and effect for two (2) years after termination of this Agreement, which coverage may be in the form of tail coverage or extended reporting period coverage if agreed by the Parties.

H. The requirements contained herein as to the types and limits of all insurance to be maintained by the Parties are not intended to and shall not in any manner, limit or qualify the liabilities and obligations assumed by the Parties under this Agreement.

I. Within ten (10) days following execution of this Agreement, and as soon as practicable after the end of each fiscal year or at the renewal of the insurance policy and in any event within ninety (90) days thereafter, each Party shall provide certification of all insurance required in this Agreement, executed by each insurer or by an authorized representative of each insurer.

J. Notwithstanding the foregoing, each Party may self-insure to the extent it maintains a self-insurance program; provided that, such Party's senior secured debt is rated at investment grade, or better, by Standard & Poor's. For any period of time that a Party's senior secured debt is unrated by Standard & Poor's or is rated at less than investment grade by Standard & Poor's, such Party shall comply with the insurance requirements applicable to it under Sections 9.1.A through 9.1.I. In the event that a Party is permitted to self-insure pursuant to this Section 9.1.J, it shall not be required to comply with the insurance requirements applicable to it under Sections 9.1.A through 9.1.I.

K. The Parties agree to report to each other in writing as soon as practical all accidents or occurrences resulting in injuries to any person, including death, and any property damage arising out of this Agreement.

ARTICLE 10. MISCELLANEOUS

10.1 Governing Law and Applicable Tariffs.

A. This Agreement for all purposes shall be construed in accordance with and governed by the laws of the State of Texas, excluding conflicts of law principles that would refer to the laws of another jurisdiction. The Parties submit to the jurisdiction of the federal and state courts in the State of Texas.

B. This Agreement is subject to all valid, applicable rules, regulations and orders of, and tariffs approved by, duly constituted Governmental Authorities.

C. Each Party expressly reserves the right to seek changes in, appeal, or otherwise contest any laws, orders, rules, or regulations of a Governmental Authority.

10.2 No Other Services. This Agreement is applicable only to the interconnection of the Plant to the TSP System at the Point of Interconnection and does not obligate either Party to provide, or entitle either Party to receive, any service not expressly provided for herein. Each Party is responsible for making the arrangements necessary for it to receive any other service that it may desire from the other Party or any third party. This Agreement does not address the sale or purchase of any electric energy, transmission service, or ancillary services by either Party, either before or after Commercial Operation.

10.3 Entire Agreement. This Agreement, including all Exhibits, Attachments, and Schedules attached hereto, constitutes the entire agreement between the Parties with reference to the subject matter hereof, and supersedes all prior and contemporaneous understandings or agreements, oral or written, between the Parties with respect to the subject matter of this Agreement. There are no other agreements, representations, warranties, or covenants which constitute any part of the consideration for, or any condition to, either Party's compliance with its obligations under this Agreement. Notwithstanding the other provisions of this Section, the Interconnection Study Agreement, if any, is unaffected by this Agreement.

10.4 Notices. Except as otherwise provided in Exhibit "D," any formal notice, demand or request provided for in this Agreement shall be in writing and shall be deemed properly served, given or made if delivered in person, or sent by either registered or certified mail, postage prepaid, overnight mail or fax to the address or number identified on Exhibit "D" attached to this Agreement. Either Party may change the notice information on Exhibit "D" by giving five (5) business days' written notice prior to the effective date of the change.

10.5 Force Majeure.

A. The term "Force Majeure" as used herein shall mean any cause beyond the reasonable control of the Party claiming Force Majeure, and without the fault or negligence of such Party, which materially prevents or impairs the performance of such Party's obligations hereunder, including but not limited to, storm, flood, lightning, earthquake, fire, explosion, failure or imminent threat of failure of facilities, civil disturbance, strike or other labor disturbance, sabotage, war, national emergency, or restraint by any Governmental Authority.

B. Neither Party shall be considered to be in Default (as hereinafter defined) with respect to any obligation hereunder (including obligations under Article 4), other than the obligation to pay money when due, if prevented from fulfilling such obligation by Force Majeure. A Party unable to fulfill any obligation hereunder (other than an obligation to pay money when due) by reason of Force Majeure shall give notice and the full particulars of such Force Majeure to the other Party in writing or by telephone as soon as reasonably possible after the occurrence of the cause relied upon. Telephone notices given pursuant to this Section shall be confirmed in writing as soon as reasonably possible and shall specifically state full particulars of the Force Majeure, the time and date when the Force Majeure occurred, and when the Force Majeure is reasonably expected to cease. The Party affected shall exercise due diligence to remove such disability with reasonable dispatch, but shall not be required to accede or agree to

any provision not satisfactory to it in order to settle and terminate a strike or other labor disturbance.

10.6 Default

A. The term “Default” shall mean the failure of either Party to perform any obligation in the time or manner provided in this Agreement. No Default shall exist where such failure to discharge an obligation (other than the payment of money) is the result of Force Majeure as defined in this Agreement or the result of an act or omission of the other Party. Upon a Default, the non-defaulting Party shall give written notice of such Default to the defaulting Party. Except as provided in Section 10.6.B, the defaulting Party shall have thirty (30) days from receipt of the Default notice within which to cure such Default; provided however, if such Default is not capable of cure within thirty (30) days, the defaulting Party shall commence such cure within thirty (30) days after notice and continuously and diligently complete such cure within ninety (90) days from receipt of the Default notice; and, if cured within such time, the Default specified in such notice shall cease to exist.

B. If a Default is not cured as provided in this Section, or if a Default is not capable of being cured within the period provided for herein, the non-defaulting Party shall have the right to terminate this Agreement by written notice at any time until cure occurs, and be relieved of any further obligation hereunder and, whether or not that Party terminates this Agreement, to recover from the defaulting Party all amounts due hereunder, plus all other damages and remedies to which it is entitled at law or in equity. The provisions of this Section will survive termination of this Agreement.

10.7 Intrastate Operation. The operation of the Plant by Generator shall not cause there to be a synchronous or an asynchronous interconnection between ERCOT and any other transmission facilities operated outside of ERCOT unless ordered by the Federal Energy Regulatory Commission under Section 210 of the Federal Power Act. The Parties recognize and agree that any such interconnection will constitute an adverse condition giving the TSP the right to immediately disconnect the TIF from the GIF, until such interconnection has been disconnected. The Generator will not be prohibited by this Section from interconnecting the Plant with facilities operated by the Comisión Federal de Electricidad of Mexico, unless such interconnection would cause ERCOT utilities that are not “public utilities” under the Federal Power Act to become subject to the plenary jurisdiction of the Federal Energy Regulatory Commission.

10.8 No Third Party Beneficiaries. This Agreement is not intended to and does not create rights, remedies, or benefits of any character whatsoever in favor of any persons, corporations, associations, or entities other than the Parties, and the obligations herein assumed are solely for the use and benefit of the Parties, their successors in interest and, where permitted, their assigns.

10.9 No Waiver. The failure of a Party to this Agreement to insist, on any occasion, upon strict performance of any provision of this Agreement will not be considered a waiver of obligations, rights, or duties imposed upon the Parties. Termination or Default of this Agreement for any reason by the Generator shall not constitute a waiver of the Generator’s legal rights to obtain an interconnection from the TSP under a new interconnection agreement.

10.10 Headings. The descriptive headings of the various articles and sections of this Agreement have been inserted for convenience of reference only and are of no significance in the interpretation or construction of this Agreement.

10.11 Multiple Counterparts. This Agreement may be executed in two or more counterparts, each of which is deemed an original but all constitute one and the same instrument.

10.12 Amendment. This Agreement may be amended only upon mutual agreement of the Parties, which amendment will not be effective until reduced to writing and executed by the Parties.

10.13 No Partnership. This Agreement shall not be interpreted or construed to create an association, joint venture, agency relationship, or partnership between the Parties or to impose any partnership obligation or liability upon either Party. Neither Party shall have any right, power, or authority to enter into any agreement or undertaking for, or act on behalf of, or to act as or be an agent or representative of, or to otherwise bind, the other Party.

10.14 Further Assurances. The Parties agree to (i) furnish upon request to each other such further information, (ii) execute and deliver to each other such other documents, and (iii) do such other acts and things, all as the other Party may reasonably request for the purpose of carrying out the intent of this Agreement and the documents referred to in this Agreement. Without limiting the generality of the foregoing, the TSP shall, at the Generator's expense, when reasonably requested to do so by the Generator at any time after the execution of this Agreement, prepare and provide such information in connection with this Agreement (including, if available, resolutions, certificates, opinions of counsel, or other documents relating to the TSP's corporate authorization to enter into this Agreement and to undertake the obligations set out herein) as may be reasonably required by any potential lender to the Generator under a proposed loan agreement. The TSP will use commercially reasonable efforts to obtain any opinion of counsel reasonably requested by Generator, but the TSP shall not be in Default of any obligation under this Agreement if the TSP is unable to provide an opinion of counsel that will satisfy any potential lender to the Generator. Specifically, upon the written request of one Party, the other Party shall provide the requesting Party with a letter stating whether or not, up to the date of the letter, that Party is satisfied with the performance of the requesting Party under this Agreement.

10.15 Indemnification and Liability. The indemnification and liability provisions of the PUCT Rule 25.202(b)(2) or its successor shall govern this Agreement.

10.16 Consequential Damages. OTHER THAN THE LIQUIDATED DAMAGES HERETOFORE DESCRIBED, IN NO EVENT SHALL EITHER PARTY BE LIABLE UNDER ANY PROVISION OF THIS AGREEMENT FOR ANY LOSSES, DAMAGES, COSTS OR EXPENSES FOR ANY SPECIAL, INDIRECT, INCIDENTAL, CONSEQUENTIAL, OR PUNITIVE DAMAGES, INCLUDING BUT NOT LIMITED TO LOSS OF PROFIT OR REVENUE, LOSS OF THE USE OF EQUIPMENT, COST OF CAPITAL, COST OF TEMPORARY EQUIPMENT OR SERVICES, WHETHER BASED IN WHOLE OR IN PART IN CONTRACT, IN TORT, INCLUDING NEGLIGENCE, STRICT LIABILITY, OR ANY OTHER THEORY OF LIABILITY; PROVIDED, HOWEVER, THAT DAMAGES FOR WHICH A PARTY MAY BE LIABLE TO THE OTHER PARTY UNDER ANOTHER

AGREEMENT WILL NOT BE CONSIDERED TO BE SPECIAL, INDIRECT, INCIDENTAL, OR CONSEQUENTIAL DAMAGES HEREUNDER.

10.17 Assignment. This Agreement may be assigned by either Party only with the written consent of the other; provided, that either Party may assign this Agreement without the consent of the other Party to any affiliate of the assigning Party with an equal or greater credit quality and with the legal authority and operational ability to satisfy the obligations of the assigning Party under this Agreement; and provided further that the Generator shall have the right to assign this Agreement, without the consent of the TSP, for collateral security purposes to aid in providing financing for the Plant; provided, that the Generator will require any secured party, trustee, or mortgagee to notify the TSP of any such assignment. Any financing arrangement entered into by the Generator pursuant to this Section will provide that prior to or upon the exercise of the secured party's, trustee's, or mortgagee's assignment rights pursuant to said arrangement, the secured creditor, the trustee, or mortgagee will notify the TSP of the date and particulars of any such exercise of assignment right(s). Any attempted assignment that violates this Section is void and ineffective. Any assignment under this Agreement shall not relieve a Party of its obligations, nor shall a Party's obligations be enlarged, in whole or in part, by reason thereof. Where required, consent to assignment will not be unreasonably withheld, conditioned, or delayed.

10.18 Severability. If any provision in this Agreement is finally determined to be invalid, void, or unenforceable by any court having jurisdiction, such determination shall not invalidate, void, or make unenforceable any other provision, agreement, or covenant of this Agreement; provided that if the Generator (or any third party, but only if such third party is not acting at the direction of the TSP) seeks and obtains such a final determination with respect to any provision of Section 4.1.B, then none of the provisions of Section 4.1.B. shall thereafter have any force or effect and the Parties' rights and obligations shall be governed solely by Section 4.1.A.

10.19 Comparability. The Parties will comply with all applicable comparability and code of conduct laws, rules, and regulations, as amended from time to time.

10.20 Invoicing and Payment. Unless the Parties otherwise agree (in a manner permitted by applicable PUCT Rules and as specified in writing in an Exhibit "E" attached hereto), invoicing and payment rights and obligations under this Agreement shall be governed by PUCT Rules or applicable Governmental Authority. Invoices shall be rendered to the paying Party at the address specified on, and payments shall be made in accordance with the requirements of, Exhibit "D."

10.21 Confidentiality.

A. Subject to the exception in Section 10.21.B, any information that a Party claims is competitively sensitive, commercial, or financial information under this Agreement ("Confidential Information") shall not be disclosed by the other Party to any person not employed or retained by the other Party, except to the extent disclosure is: (i) required by law; (ii) reasonably deemed by the disclosing Party to be required to be disclosed in connection with a dispute between or among the Parties, or the defense of litigation or dispute; (iii) otherwise permitted by consent of the other Party, such consent not to be unreasonably withheld; or (iv)

necessary to fulfill its obligations under this Agreement or as a transmission service provider or a Control Area operator including disclosing the Confidential Information to ERCOT. The Party asserting confidentiality shall notify the other Party in writing of the information it claims is confidential. Prior to any disclosures of the other Party's Confidential Information under this subsection, or if any third party or Governmental Authority makes any request or demand for any of the information described in this subsection, the disclosing Party agrees to promptly notify the other Party in writing and agrees to assert confidentiality and cooperate with the other Party in seeking to protect the Confidential Information from public disclosure by confidentiality agreement, protective order or other reasonable measures.

B. This provision shall not apply to any information that was or is hereafter in the public domain (except as a result of a breach of this provision).

Exhibit "B"
Time Schedule

1) Interconnection Option chosen by Generator (check one):
 Section 4.1.A. or Section 4.1.B

A. If Section 4.1.B is chosen by Generator, the In-Service Date(s) was determined by (check one): (1) good faith negotiations, or (2) designated by Generator upon failure to agree.

2) April 17, 2020 is the date ("NTP Need Date") by which Generator must provide a written Notice to Proceed with design, procurement, and construction of the TIF and provide security, as specified in Exhibit "A", Section 4.2 and 4.3, so that TSP may maintain schedule to meet the In-Service Date identified below. The NTP date shall be the date Generator provides written Notice to Proceed to TSP:

A. If Generator does not provide a written Notice to Proceed to TSP by the above NTP Need Date, the designated TIF In-Service Date, Scheduled Generation Trial Operation Date, and Scheduled Generation Commercial Operation Date, identified below, will each be extended day for each day after the NTP Need Date that the Notice to Proceed is delayed.

B. If Generator does not provide a written Notice to Proceed and provide security in accordance with Exhibit "E" to TSP by eighteen (18) months after the NTP Need Date ("NTP Deadline"), such non-provision of the Notice to Proceed shall constitute a Default, in accordance with Section 10.6.A of Exhibit "A", by the Generator and written notice of Default shall be deemed to have been given by TSP to Generator on the NTP Deadline. If such Default is not cured in accordance with Section 10.6 of Exhibit "A", then TSP may terminate this Agreement in accordance with the provisions of Section 10.6.B of Exhibit "A".

Generator Main Transformer Tap Position Communication to TSP Date: (If Generator Main Transformer(s) is equipped with a no-load tap changer)
September 15, 2021

TIF In-Service Date (Backfeed): The later of:

- a) September 30, 2021; or
- b) Thirteen (13) months after the NTP Date.

Scheduled Generation Trial Operation Date (Synchronization): The later of:

- a) October 1, 2021; or
- b) One (1) month after the TIF In-Service Date.

Scheduled Generation Commercial Operation Date (COD): The later of:

- a) December 15, 2021; or
- b) Three (3) months after the TIF In-Service Date.

Nothing in the definitions of the dates above shall preclude either Party from taking measures or actions that allow the actual Generation Trial Operation Date or the actual Generation Commercial Operation Date to be earlier than the scheduled dates above.

- 3) Due to the nature of the subject of this Agreement, the Parties may mutually agree to change the dates and times of this Exhibit B.

Exhibit "C" Interconnection Details

1. Name: Roadrunner Crossing Wind Farm
2. Point of Interconnection (POI) Location: The POI between the GIF and TIF will be located at a new Transmission Service Provider (TSP) owned dead-end structure at the end of the TSP's new 345 kV line connecting from the new TSP Reata Station to a location adjacent to the GIF step up station (shown on Attachment "C-1" and "C-2"). The POI shall be the physical point where the TIF connects to the GIF. This point is more specifically defined as being located at the 4-hole pad terminals on the insulator hardware at the dead-end structure where the TSPs 345 kV transmission line connects to Generator owned slack span connection to the GIF.
3. Delivery Voltage: 345 kV
4. Number and Size of Generating Units: The total capacity of Roadrunner Crossing Wind 1 is 200.2 MW composed of 91 Model V120 & Manufacturer Vestas 2.2 MW Turbines.
5. Type of Generating Unit: Vestas V120 2.2 MW turbines

The Parties will amend this Exhibit "C" as necessary to reflect any changes Generator makes to the manufacturer, model, or type of generating units.

6. Metering and Telemetry Equipment: Metering (voltage, location, losses adjustment due to metering location and other), telemetry, and communications requirements shall be as follows:
 - 6.1 TSP shall, in accordance with ERCOT Requirements and Good Utility Practice, install, own, operate, inspect, test, calibrate, and maintain 345 kV metering accuracy potential and current transformer and associated metering and telemetry equipment (including communications and an RTU) located in the TIF. A one-line diagram showing TSP's ERCOT-poll settlement ("EPS") metering location is attached to this Exhibit "C" as **Attachment C-2**. If requested by Generator, and if available from the TSP RTU equipment, TSP will make Primary EPS metering data available to Generator via a communication link at Generator's expense. If such metering data are not available from TSP RTU equipment, they may be available by alternate means at Generator's expense. Such data, if provided to Generator, will be for Generator's informational purposes only. Generator shall not rely on such data, as the primary source, for the metering data addressed in Section 6.2 of this Exhibit "C" below, or for any other scheduling or operational purposes. TSP makes no guarantee of the quality or availability of such data. The provision of Section 5.5(G) of Exhibit "A" shall not apply to TSP's RTU.

- 6.2 Generator shall, in accordance with Good Utility Practice, install, own, operate, inspect, test, calibrate, and maintain the necessary metering potential and current transformers and associated metering and telemetry equipment in the GIF and/or Plant to satisfy the ERCOT Requirements for the provision of metering data by Generator's "Qualified Scheduling Entity".
- 6.3 Generator shall, in accordance with ERCOT Requirements and Good Utility Practice, install, own, operate, inspect, test, calibrate, and maintain the metering and telemetry equipment (including an RTU or other equipment acceptable to TSP) to supply all electrical parameters of the Plant and GIF, as specified in Section 11 to this Exhibit "C", to TSP at a location designated by TSP.
- 6.4 Prior to the In-Service Date, acceptance tests will be performed by TSP and Generator to ensure the proper functioning of all metering, telemetry, and communications equipment, and to verify the accuracy of data being received by TSP.
- 6.5 Following the Commercial Operation date, each Party shall test its metering, telemetry, and communications equipment in accordance with ERCOT Requirements and Good Utility Practice. Each Party shall give the other Party reasonable advance notice of such testing. Each Party shall have the right to observe testing performed by the other Party.
- 6.6 Any changes to Generator's metering, telemetry, and communication equipment, including meters, voltage transformers, current transformers, and associated RTU, panels, hardware, conduit and cable, that will affect the data being received by TSP hereunder must be mutually agreed to by the Parties.
- 6.7 Each Party will promptly advise the other Party if it detects or otherwise learns of any metering, telemetry, or communications equipment or related situation that requires attention and/or correction by the other Party.

7. Generator Interconnection Facilities:

Generator will be responsible for the construction and ownership of the below:

- 7.1 Generator will be responsible for the construction and ownership of a 345 kV station and all facilities within it. Specifically, Generator's interconnection station(s) including control building(s), 345 kV step-up transformer(s), transformer protection package(s), 345 kV circuit breaker(s), 345 kV line disconnect switch(es), and protective relaying panels for the Generator's 345 kV line(s) that will coordinate with the TSP's line panels at the TSP facility for the Generator line protection

- 7.2 345 kV line(s) with all necessary material to interconnect to Generator's dead-end structure(s) located right adjacent to the TIF, and the crossing of the existing TSP Transmission Line which is required to accommodate the Generator 345 kV line(s) in accordance to Exhibit "B" Section 8.2
- 7.3 Full tension, dead-end, 345 kV line structure(s) located adjacent to the TIF (Generator shall coordinate the height of this structure(s), the arrangement of the phases, and the exact location of the structure(s) with TSP) NOTE: Generator shall provide any necessary jumper post insulators for this structure(s)
- 7.4 Fiber optic cable (Alcoa Fujicura or equivalent 48 fiber, single-mode, fiber optic OPGW) from GIF's control building to TSP's OPGW cable splice box on the Generator's interconnecting structure(s) at the Point of Interconnection
- 7.5 Multi-ported RTU(s) and panels to provide breaker status, telemetry and energy data from the GIF to the Plant, the TSP, Generator and ERCOT
- 7.6 Associated structures, buswork, conductor, connectors, grounding, conduit, control cable, foundation work, perimeter fencing, grading/dirt work and any appurtenances necessary for construction and operation of GIF

The GIF also includes the communication facilities described in Section 9.1 below.

8. Transmission Service Provider Interconnection Facilities:

- 8.1 In order for TSP to provide an interconnect to the Generator at the new TSP 345 kV station, the following new equipment will be required to be in place prior to energization.

Transmission Line:

- 2-3 miles of 345 kV transmission line from the new TSP station to the Generator step up station
- (1 Lot) – Certificate of Convenience and Necessity
- (1 Lot) – Right of way clearing
- (1 Lot) – Gates
- (1 Lot) – Transmission line structures
 - Tangents
 - Angles
 - Dead-ends
- (1 Lot) – Foundations
 - Select backfill
 - Reinforced concrete

- (1 Lot) – Transmission line grounding
- (1 Lot) – Wire
 - Conductors
 - 48-fiber Fiber Optic Ground Wire
 - 7 #8 Alumoweld Shield
- (1 Lot) – Insulators, clamps, fittings, splices and related appurtenances

Station Physical:

- (2) – 500kV, 5000 A, 63kA Gas Circuit Breaker (GCB)
- (1) – 345kV, 5000 A, 63kA GCB
- (1) – 345kV, 2000 A, 63kA GCB
- (1) – 345kV, 100 MVA, oil filled shunt reactor
- (16) – 345kV, motor operated GCB Isolation Switch
- (3) – 345kV, Motor Operated Line Isolation Switch
- (3) – 345 kV, Motor Operated Grounding Switches
- (3) – 345 kV, Line Trap with Tuner
- (12) – 345 kV, Surge Arresters
- (7) – 345 kV, Capacitive Coupling Voltage Transformers
- (2) – 345 kV, Capacitive Coupling Voltage Transformers with Carrier
- (3) – 345 kV, Extended Range Metering Current Transformers
- (3) – 345 kV, Metering Voltage Transformers
- (2) – 345kV, SSVT Sets
- (1 Lot) – Conduit and Grounding
- (1 Lot) – Aluminum Bus, Stranded Jumpers, and Connectors

Station Civil & Structural:

- (1 Lot) – Site Work/Water Diversion
- (1 Lot) – Ground Grid
- (1 Lot) – Security Fence
- (1 Lot) – Lot Final Surfacing (Crushed Limestone)
- (1 Lot) – Foundations
- (1) – 24' x 65' Control House
- (1 Lot) – Structural Steel
 - A-frames
 - Bus supports
 - Equipment supports

Relay & Control:

The TSP station control house will have room to install the additional metering and relaying panels, and any other equipment as needed:

- ERCOT Polled Settlement Metering Panel
 - Primary ERCOT Polled Settlement Meter
 - Backup ERCOT Polled Settlement Meter
- (1 Lot) – Relays & panels, load centers and batteries
- (1 Lot) – Control Cable Installation and Termination

Line protection transfer trip requirements and control system requirements are as follows:

Line Protection Requirements at TSP's station:

- a) 345 kV Transmission Lines
 - I. Compatible (SEL411) Line Distance protection
 - II. Compatible (SEL311L) Line Current Differential protection
 - III. Compatible Pulsar ULPC
 - IV. Compatible Multifunction Recorder (DFR – APP)
- b) Customer 345 kV Generator Tie Lines
 - I. Compatible (SEL 411L) Primary Line Current Differential Protection
 - II. Compatible (SEL 411L) Backup Line Current Differential Protection
- c) Compatible (SEL451) breaker failure protection with direct transfer trip via fiber optic communications to trip Customer 345 kV breaker
- d) In the case where both line terminal breakers are open, an anti-islanding transfer trip via fiber optic communications to trip Customer breaker(s) or Generator Step Up 345 kV breaker (should open at the synchronizing breaker)
- e) No automatic reclosing; use dead line, hot bus permissive controls for closing line breakers

Line Protection Requirements at Customer Facilities:

- a) Customer 345 kV breaker failure protection to send direct transfer trip via fiber optic communications to trip TSP's new Reata Station 345 kV breakers

9. Communications Facilities:

- 9.1 Generator shall, in accordance with ERCOT Requirements and Good Utility Practice, provide communications facilities that are, or may in the future be, necessary for effective interconnected operation of the Generator's Plant with the transmission system.
- 9.2 TSP will bear the costs of its communications facilities at the new Reata Station.

10. System Protection Equipment:

Protection of each Party's system shall meet the following TSP requirements in addition to ERCOT Requirements. If there is a conflict between the TSP requirements below and ERCOT Requirements, the ERCOT Requirements shall prevail.

- 10.1 Generator and TSP shall design, install, operate, maintain and test system protection equipment consistent with the applicable criteria as described in the ERCOT Requirements and any applicable requirements of Governmental Authorities, including NERC Reliability Standards. Generator shall, at its expense, provide modifications or additions to its control and protective equipment required to comply with changes in ERCOT Requirements or requirements of Governmental Authorities, including NERC Reliability Standards.
- 10.2 Generator, using Good Utility Practice, shall install sufficient digital fault recording equipment to thoroughly analyze all system disturbances occurring on the Plant and GIF to thoroughly analyze the Plant and GIF performance during system disturbances on the ERCOT system. This equipment shall monitor the voltages at major nodes, current at major branches, breaker and switch positions, and dc logic in the relay control scheme.
- 10.3 TSP assumes no responsibility for the protection of the Plant and GIF for any or all operating conditions. Generator is solely responsible for protecting its equipment in such a manner that faults, Sub-Synchronous Oscillations ("SSO"), or other disturbances on the TSP System or other interconnected system do no cause damage to the Plant and GIF.
- 10.4 It is the sole responsibility of the Generator to protect its Plant and GIF from excessive negative sequence currents.
- 10.5 The GIF shall be designed to isolate any fault, or to disconnect from or isolate any abnormality that would negatively affect the TSP's system. The Generator shall be responsible for protection of its facilities. TSP reserves the right to isolate the Plant and GIF consistent with ERCOT Requirements and NERC Reliability Standards for any of the following reasons:

1. The Plant or GIF, upon TSP's determination, cause objectionable interference with other customers' service or with the secure operation of the TSP System.
2. The Plant output as determined by TSP exceeds the operating boundaries outlined above.
3. Generator's control and protective equipment causes or contributes to a hazardous condition. TSP reserves the right to verify all protective equipment including, but not limited to including relays, circuit breakers, at the inter-tie location. Verification by TSP may include the tripping of the tiebreaker by the protective relays.
4. In TSP's opinion, continued parallel operation is hazardous to Generator, the TSP System or to the general public.
5. To provide TSP or TSP personnel the clearances for dead line or live line maintenance.

TSP shall notify Generator before disconnection, except for an emergency situation requiring immediate action. TSP will attempt to notify Generator before upon disconnection, but notification may not be possible in emergency situations that require immediate action.

- 10.6 Prior to In-Service Date, Generator shall specify whether automatic reclosing should be applied to the Generator's transmission facilities in the GIF. Automatic reclosing is normally applied to transmission circuits. When TSP's source breakers trip and isolate the Plant and GIF, Generator shall insure the Plant and GIF are disconnected from the TSP circuit prior to automatic reclosure by TSP. Automatic reclosing out-of-phase with the Plant may cause damage to Generator's equipment. Generator is solely responsible for the protection of his equipment from automatic reclosing by TSP.
- 10.7 TSP shall specify system protection and control schemes for the Point of Interconnection. Generator shall have the right to review and comment on such schemes and TSP shall consider Generator's comments when determining such schemes. Generator will install and maintain System Protection Equipment that is compatible with TSP's System Protection Equipment. TSP will work with the Generator to coordinate the establishment of the relay settings for System Protection Equipment owned by both Generator and TSP associated with the Point of Interconnection.
- 10.8 Documentation of all protective device settings shall be provided to TSP. The setting documentation shall also include relay type, model/catalog number, and setting range. If automatic transfer schemes or unique or special protective schemes are used, a description of their operation should be included. TSP must review and approve the settings of all protective

devices and automatic control equipment which: i) serve to protect the TSP System from hazardous currents and voltages originating from the Plant; or ii) must coordinate with System Protection Equipment or control equipment located on the TSP System.

11. Inputs to Telemetry Equipment:

11.1 Generator shall comply with ERCOT Requirements for telemetry and will coordinate with TSP for additional points if telemetry is deemed necessary by TSP.

12. Supplemental Terms and Conditions:

12.1 Additional Studies – If it is necessary for TSP to perform any additional generation interconnection studies associated with the Plant in accordance with ERCOT Requirements, the Parties will enter an agreement, in form and substance reasonably acceptable to the Parties, to perform those studies and Generator shall pay TSP for the studies pursuant to that agreement.

12.2 Switching Procedures – Each Party will adopt formal switching procedures that govern safety related issues concerning the operation of its switches connected to these Points of Interconnection and will provide a copy of those procedures to the other Party prior to In-Service Date. Each Party will agree to comply with the aforementioned switching procedures of the other Party applicable to the Point of Interconnection and will notify the other Party in writing of any changes to its procedures relating to the Point of Interconnection.

12.3 Facility Connection Requirements – Generator will construct its facilities in accordance with the version of LST-FAC-001-PRO-Facility_Connection_Requirements that is in effect at the time the Generator gives its notice to proceed with design and procurement, as referenced in Exhibit “B”.

12.4 Generator shall submit drawings of the GIF to TSP for review. TSP will review only those portions of the drawings that affect the TSP System. Any changes required by TSP shall be made prior to final issue of drawings and TSP shall be provided with final copies of the revised drawings. TSP will review only those portions of the drawings which apply to protection, metering and monitoring of the TSP System. To aid Generator, TSP may make suggestions on other areas. TSP’s review of Generator’s drawings shall not be construed as confirming or endorsing the design or as any warranty of safety, durability, or reliability of the facility or equipment. Generator shall provide copies of the following:

1. one-line and three-line diagrams indicating the following:

1. equipment names and/or numerical designations for all circuit breakers, contactors, air switches, transformers, generators, etc., associated with the generation as required by TSP to facilitate switching
 2. power transformers – nameplate or designation, nominal kVA, nominal primary, secondary, tertiary voltages, vector diagram showing winding connections, tap setting and transformer impedances (transformer test report showing the positive sequence, zero sequence, test voltages and MVA base for each winding)
 3. station service transformers – phase(s) connected and estimated kVA load
 4. instrument transformers – voltage and current, phase connections
 5. surge arresters/gas tubes/metal oxide varistors/avalanche diode/spill gaps/surge capacitors, etc. – type and ratings
 6. capacitor banks – kVAR rating and reactive (static and dynamic) device operation capability
 7. reactive device capability (required for wind generation only) – kVAR rating and reactive device operation capability for static and dynamic devices for each generation collection feeder
 8. disconnect switches – status if normally open (N.O.), manual or motor operated including switch voltage, continuous and interrupting ratings
 9. circuit breakers and/or contactors – interrupting rating, continuous rating, operating times
 10. generator(s) – nameplate, test report, type, connection, kVA, voltage, current, rpm, power factor, impedances, time constants, etc.
 11. Point of Interconnection and phase identification
 12. fuses – manufacturer, type, size, speed, and location
 13. transmission structure geometry (phase-to-phase, phase-to-ground, and shield-to-phase), phase conductor data, shield wire data, transmission line ratings, positive and zero sequence impedances and mileage
2. potential and current drawings associated with the protection and control schemes for the Plant and GIF and control drawings of the Plant and interconnection circuit breaker indicating the following:

1. terminal designation of all devices – relay coils and contacts, switches, transducers, etc.
2. relay functional designation – per latest ANSI Standard where the same functional designation shall be used on all drawings showing the relay
3. complete relay type (such as CV-2, SEL321-1, REL-301, IJS51A, etc.)
4. switch contact as referenced to the switch development if development is shown on a separate drawing
5. switch developments and escutcheons where the majority of contacts are used. Where contacts of a switch are used on a separate drawing, that drawing should be referenced adjacent to the contacts in the switch development. Any contacts not used should be referenced as spare.
6. all switch contacts shown open with each labeled to indicate the positions in which the contact will be closed with explanatory notes defining switch coordination and adjustment where misadjustment could result in equipment failure or safety hazard
7. auxiliary relay contacts as referenced to the coil location drawing if coil is shown on a separate drawing where all contacts of auxiliary relays should be shown and the appropriate device auxiliary switches (circuit breakers, contactor) as referenced to the drawing where they are used.
8. any interlocks – electromechanical, key, etc., associated with the generation or interconnection station
9. ranges of all timers and setting if dictated by control logic
10. all target ratings; on dual ratings note the appropriate target tap setting
11. complete internal for electromechanical protective relays where microprocessor type relays may be shown as a “black box”, with manufacturer’s instruction book number referenced and terminal connections shown
12. isolation points (states links, PK-2 and FT-1 blocks), etc. including terminal identification
13. all circuit elements and components, with device designation, rating and setting where applicable and where coil voltage is shown only if different from nominal control voltage
14. size, type, rating and designation of all fuses

15. phase sequence designation as ABC or CBA
 16. potential transformers – nameplate ratio, polarity marks, rating, primary and secondary connections
 17. current transformers (including auxiliary CT's) – polarity marks, rating, tap ratio and connection
- 12.5 Generator may not commence parallel operation of the Plant until consent has been given by TSP. TSP reserves the right to inspect the GIF and witness testing of any equipment or devices associated with the Point of Interconnection.
- 12.6 The Plant and GIF shall not cause objectionable interference with the electric service provided to other customers of TSP nor jeopardize the security of the ERCOT power system. In order to minimize objectionable interference of the Plant and GIF, the Plant and GIF shall meet the following criteria as described in TSP's LST-FAC-001-PRO-Facility_Connection_Requirements for the below:
- Voltage,
 - Flicker,
 - Frequency,
 - Harmonics, telephone interference, carrier interference,
 - Fault and line clearing,
 - Excitation system and Automatic Voltage Regulation, and
 - Governor system.
- 12.7 The dynamic MVAR capability at the current MW generation amount shall be provided in real time. If this dynamic MVAR capability is not available in real time, a dynamic capability curve plotted as a function of MW output shall be provided. The shunt static reactive available, but not in service, shall be provided in sufficient detail to determine the amount of dynamic and static reactive reserve available.
- 12.8 Generator shall provide Voltage Support Service and Reactive Power Requirements as required by ERCOT Nodal Protocols Section 3.15.
- 12.9 Certain generators are susceptible to SSO when interconnected within electrical proximity of series capacitor banks on the transmission system. Prior to the In-Service Date, the Generator will provide complete and accurate studies which analyze the potential of SSO and will coordinate with TSP and ERCOT regarding the scope of such studies. Generator is responsible for mitigation to protect itself from SSO risks. TSP will work with Generator and their selected turbine-generator manufacturer on any system data required for such studies.

- 12.10 TSP considers the energy and power that the Plant and GIF may from time to time consume from the transmission grid through the Point of Interconnection to be a retail transaction and as such, TSP does not intend to be the provider of this retail service. Generator shall make necessary arrangements with the appropriate retail supplier for the energy and power that the Plant and GIF may consume from the transmission grid through the Point of Interconnection.
- 12.11 Generator shall notify TSP in writing as to which initial ERCOT Qualified Scheduling Entity the Plant will be scheduling through and any changes made thereafter.
- 12.12 Upon written request from TSP, Generator shall supply notification to TSP identifying their retail service provider.
- 12.13 Generator shall use commercially reasonable efforts to change the GIF as may be reasonably required by TSP to meet future changes in the TSP System. Generator shall be given reasonable notice by TSP prior to the date that any such required change in the GIF must be made.
- 12.14 Each Party will comply with NERC Reliability Standards applicable to its facilities identified in this Exhibit "C". Each Party shall provide to the other Party all information related to its interconnection facilities that may reasonably be required by the other Party to comply with NERC Reliability Standards applicable to its interconnection facilities, if any. "NERC Reliability Standards" means the mandatory electric reliability standards established and enforced by the North American Electric Reliability Corporation or its successor electric reliability organization.
- 12.15 Encroachment – Generator must submit a written request to TSP (using a form of request acceptable to TSP) and obtain prior written authorization from TSP prior to conducting any activities within any portion of TSP's transmission line right of way and/or substation property. Such Generator activities shall include, but are not limited to: i) constructing transmission lines, communication facilities, roads, water lines, sewer lines, gas pipelines, or any other facilities; ii) storing any equipment or materials; or iii) changing the grade, elevation, or contour of the land, for such encroachment prior to Generator installing such facilities or conducting such activities. TSP RESERVES THE RIGHT TO DELAY THE ENERGIZATION FOR THE POINT OF INTERCONNECTION UNTIL GENERATOR OBTAINS ALL REQUIRED WRITTEN AUTHORIZATIONS FROM TSP FOR SUCH ENCROACHMENTS, IF ANY. The Generator will be responsible for the cost of all modifications necessary on property or facilities owned by TSP that are affected by such encroachment. The provision of overall site plans by Generator shall not relieve Generator from the obligation to submit all encroachment requests in accordance with this subsection.

13. Special Operating Conditions, if any, attached:
 - 13.1 If Generator's main power transformer(s) is equipped with a no-load tap changer, in accordance with ERCOT Requirements, Generator will work with TSP to select the tap position on the no-load tap changer of the Generator's main power transformer(s). Generator will initiate contact with TSP to select such tap position no later than the date specified in Exhibit B. notwithstanding TSP's obligations in the remainder of this Agreement, TSP shall have no obligation to establish an electrical interconnection with the GIF until Generator and TSP have selected the tap position.

Generator shall design, construct, operate and maintain GIF with accordance with all applicable ERCOT Requirements and NERC Reliability Standards.

For thermal powered generation, Generator will provide TSP at least thirty (30) minutes' prior notice before coming on-line or off-line so TSP can adjust reactive resources.
14. The difference between the estimated cost of the TIF under 4.1.A (N/A) and the estimated cost of the TIF under 4.1.B (N/A) is: N/A, if applicable.

DocuSign Envelope ID: 2A15E12D-317E-4F57-9438-F1ADD206C024

Attachment C-1
 Conceptual Point of Interconnection

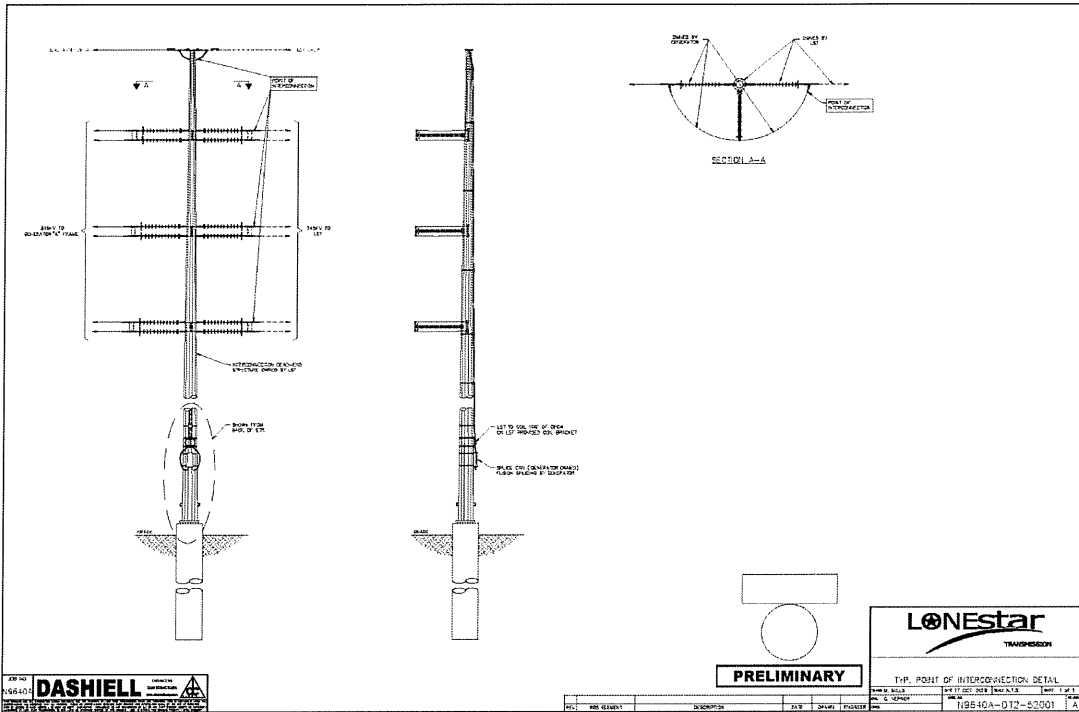

DocuSign Envelope ID: 2A15E12D-317E-4F57-9438-F1ADD206C024

Attachment C-2
 Conceptual One-Line Drawing

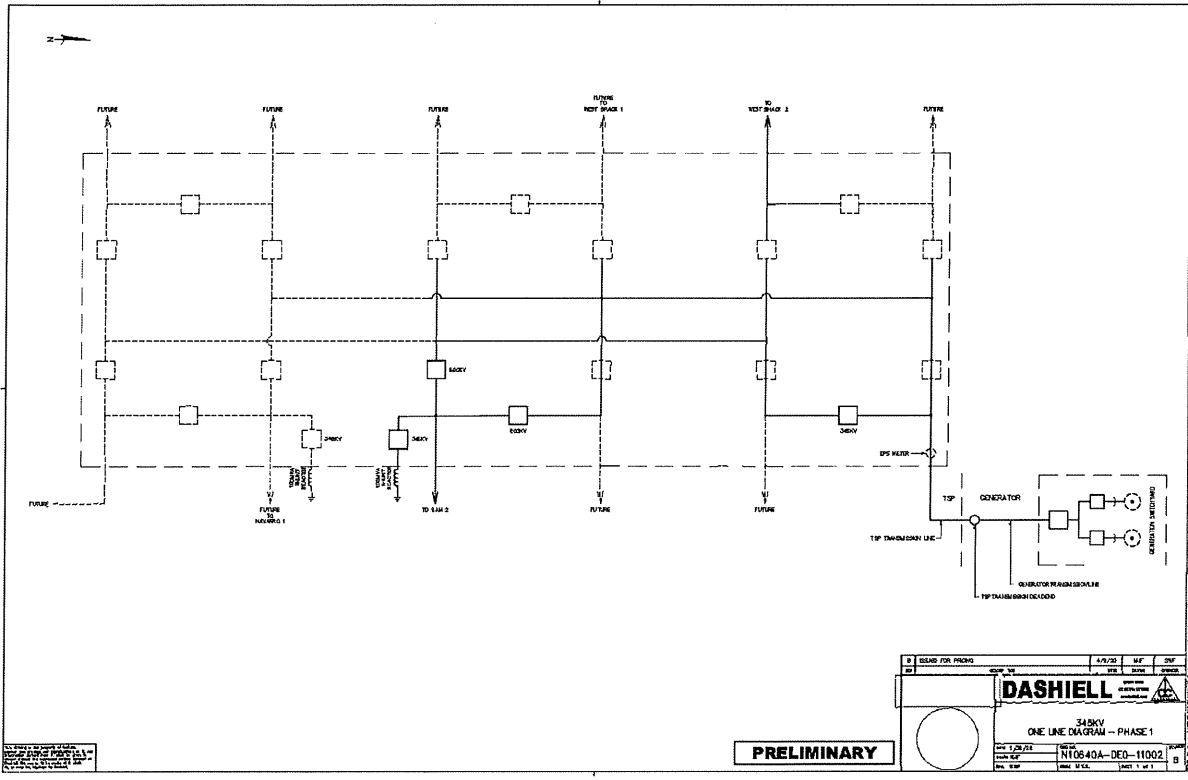

DocuSign Envelope ID: 2A15E12D-317E-4F57-9438-F1ADD206C024

Attachment C-3
 Project Overview Map

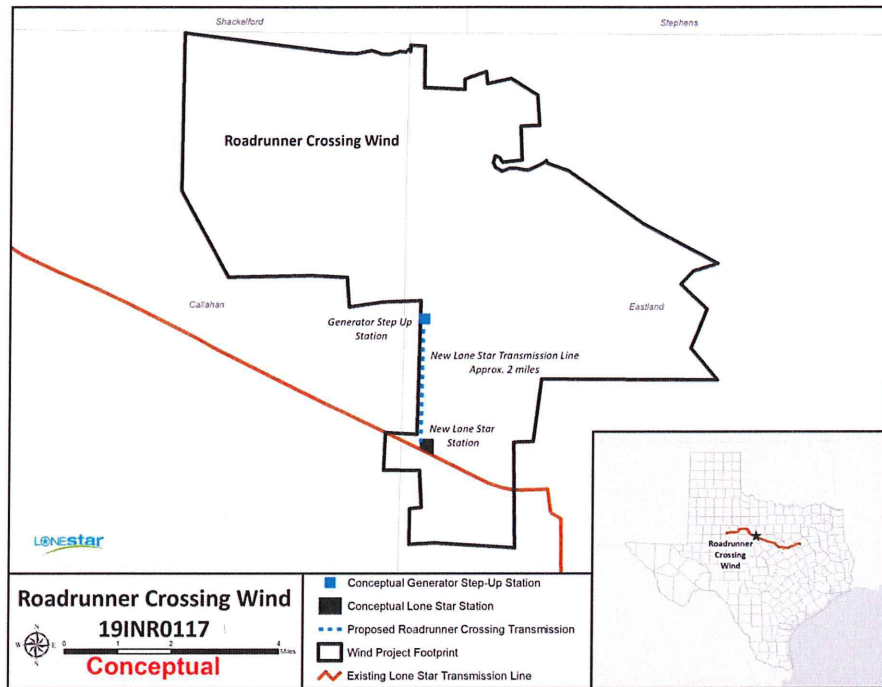

DATE: April 17, 2020

Exhibit “D”

Notice and EFT Information of the ERCOT Standard Generation Interconnection Agreement

(a) All notices of an operational nature shall be in writing and/or may be sent between the Parties via electronic means including facsimile as follows:	
<p>If to Generator:</p> <p>Company Name: Roadrunner Crossing Wind Farm, LLC Attn: Transmission Manager Address: 701 Brazos St, Suite 1400 Austin, TX 78701 Telephone Number: 512-658-9951 Email: Transmission@rwe.com</p> <p>Copy to: RWE Renewables Americas Attn: North American Renewables Operations Manager 701 Brazos St, Suite 1400 Austin, TX 78701 24 hr number: 512-482-8008 Email: gendispatch@rwe.com</p>	<p>If to Transmission Service Provider:</p> <p>Lone Star Transmission, LLC Attn: David Turner, Director of Operations 5920 W. William Cannon Dr., Bldg. 2, Austin, TX 78749 24 Hour Telephone: (512) 949-2600 Operational/Confirmation Fax: (512) 949-2626 Email: David.Turner@lonestar-transmission.com</p>
(b) Notices of an administrative nature:	
<p>If to Generator:</p> <p>Company: RWE Renewables Americas Attn: Transmission Manager Address: 701 Brazos St, Suite 1400 Austin, TX 78701 Phone: 512-658-9951 Email: Transmission@rwe.com</p> <p>Copy to: RWE Renewables Americas Attn: General Counsel 701 Brazos st, Suite 1400 Austin, TX 78701 Phone number: 512-482-4009 Email: USlegal@rwe.com</p>	<p>If to Transmission Service Provider:</p> <p>Lone Star Transmission, LLC Attn: Amir Memic, Director of Development 5920 W. William Cannon Dr., Bldg. 2, Austin, TX 78749 24 Hour Telephone: (512) 236-3138 Operational/Confirmation Fax: (512) 949-2626 Email: Amir.Memic@lonestar-transmission.com</p>
(c) Notice for statement and billing purposes:	
<p>If to Generator:</p>	<p>If to Transmission Service Provider:</p>

<p>Roadrunner Crossing Wind Farm, LLC c/o RWE Renewables Americas Address: 353 N Clark St, 30th Floor Chicago, IL 60654</p>	<p>Company Name: Lone Star Transmission, LLC c/o NextEra Energy Transmission, LLC 700 Universe Blvd. (UST/JB), Juno Beach, FL 33408 Email: customerservice@lonestar-transmission.com</p>
<p>(d) Information concerning electronic funds transfers:</p>	
<p>If to Generator:</p>	<p>If to Transmission Service Provider:</p> <p><u>ACH Instructions</u> Bank Name: Bank of America Global Finance City, State: Dallas, TX ABA No: 111-000-012 Swift: BOFAUS3N For credit to: Lone Star Transmission, LLC Account No.: 4426849087</p> <p><u>Wire Instructions</u> Bank Name: Bank of America City, State: New York, NY ABA No.: 0260-0959-3 Swift: BOFAUS3N For credit to: Lone Star Transmission, LLC Account No.: 4426849087</p>

Exhibit “E”
Security Arrangement Details

On or before the date that Generator issues the written Notice to Proceed, Generator shall cause to be established (the date of such establishment shall be the “Security Effective Date”), and shall at all times through the earlier of (i) five (5) business days after the date upon which TSP receives written notification from Generator that Commercial Operation has been achieved or (ii) ninety (90) days after the termination of the Agreement in accordance with its terms (the earlier of which shall be the “Final Expiration Date”), cause to be maintained in full force and effect an “Irrevocable Standby Letter of Credit,” corporate guaranty, or other form of collateral security (“Security”) for the benefit of TSP in a commercially acceptable form consistent with this Exhibit E and otherwise acceptable to TSP and Generator, which acceptance shall not be unreasonably withheld, in the amount totaling Twenty-Four Million, Nine Hundred and Ten Thousand Dollars (**\$24,910,000**).

Depending on the creditworthiness of the proposed guarantor, a corporate guaranty may or may not be acceptable Security. TSP requires that the guarantor providing any corporate guaranty shall maintain a senior unsecured credit rating of BBB- or the equivalent by Standard & Poor’s, Moody’s Investor Service, or Fitch Ratings, Inc. If Generator chooses to provide a corporate guaranty, it shall provide any financial reports requested by TSP upon execution of this Agreement and agrees to provide financial information concerning the guarantor as may be requested from time to time by TSP. If the creditworthiness of the proposed guarantor is acceptable to TSP, the corporate guaranty shall be in a form acceptable to TSP. If rated by one or more rating agencies and the ratings are split, the lowest rating should be the applicable standard.

“Irrevocable Standby Letter of Credit” shall mean an irrevocable, transferable letter of credit, issued by a Generator-selected and TSP-approved (which approval shall not be unreasonably withheld), major U.S. commercial bank, or a U.S. branch office of a major foreign commercial bank, with a credit rating of at least “A-” by Standard & Poor’s or “A3” by Moody’s Investor Services (“Bank”). The Irrevocable Standby Letter of Credit shall be transferable, more than one time, in whole but not in part, in favor of any party whom TSP certifies has succeeded to TSP’s right, title, and interest in and to this Agreement. Should TSP transfer such Irrevocable Standby Letter of Credit as stated above, Generator shall reimburse TSP for any costs it incurs from the Bank associated with such transfers.

If, at any time during the Term of this Agreement, the Bank suffers a credit rating reduction to less than “A-” by Standard & Poor’s or “A3” by Moody’s Investor Service, Generator shall replace that Irrevocable Standby Letter of Credit with another Irrevocable Standby Letter of Credit of the same amount and with the same beneficiary from another TSP-approved bank of Generator’s choice within fifteen (15) business days of the date of such event. In the event of a failure to provide a substitute Irrevocable Standby Letter of Credit within the time period specified above, TSP may draw upon the Irrevocable Standby Letter of Credit to secure a cash deposit as security under this Agreement.

The Irrevocable Standby Letter of Credit may consist of one or more consecutive terms (each, a “Term”), the first of which shall be effective on or before the Security Effective Date

and the last of which shall expire no earlier than the Final Expiration Date; provided, that, the Irrevocable Standby Letter of Credit shall automatically renew from Term to Term without amendment such that there shall be no interruption of surety provided by the Irrevocable Standby Letter of Credit from the Security Effective Date through the Final Expiration Date.

To the extent that the Bank has the unilateral right not to renew the Irrevocable Standby Letter of Credit for a successive Term, the Bank shall give notice to TSP and Generator in writing by certified mail, return receipt requested, or via a courier service, of the exercise of its right not to renew the Irrevocable Standby Letter of Credit for a successive term (an “Expiring Term”) not less than ninety (90) days prior to the expiration date of any Expiring Term. Generator hereby agrees that in the event that the Bank gives such notice and Generator does not provide TSP with a substitute Irrevocable Standby Letter of Credit in substantially the same form as the expiring Irrevocable Standby Letter of Credit at least forty-five (45) days prior to the expiration date of any Expiring Term, TSP shall have the right to retain as security the full amount (as specified in the Irrevocable Standby Letter of Credit) of the expiring Irrevocable Standby Letter of Credit. The substitute Irrevocable Standby Letter of Credit shall meet the requirements of this Exhibit E and be otherwise acceptable to TSP and Generator, which acceptance shall not be unreasonably withheld. In the event of a failure to provide a substitute Irrevocable Standby Letter of Credit within the time period specified above, TSP may draw upon the Irrevocable Standby Letter of Credit to secure a cash deposit as security under this Agreement.

In the event that an Irrevocable Standby Letter of Credit is set to expire on a date prior to the Final Expiration Date and Generator has not provided to TSP a substitute Irrevocable Standby Letter of Credit at least forty-five (45) days in advance of such expiration, TSP shall have the right to retain as security the full amount (as specified in the Irrevocable Standby Letter of Credit) of the expiring Irrevocable Standby Letter of Credit. The substitute Irrevocable Standby Letter of Credit shall meet the requirements of this Exhibit E and be otherwise acceptable to TSP and Generator, which acceptance shall not be unreasonably withheld. In the event of a failure to provide a substitute Irrevocable Standby Letter of Credit within the time period specified above, TSP may draw upon the Irrevocable Standby Letter of Credit to secure a cash deposit as security under this Agreement.

Except to the extent that the Bank has the unilateral right not to renew the Irrevocable Standby Letter of Credit for a successive Term, the Irrevocable Standby Letter of Credit to be issued in connection herewith shall have no provision for termination by the Bank or Generator.

Within five (5) business days after the Final Expiration Date, TSP shall (i) mark the Irrevocable Standby Letter of Credit, if any, then held by TSP as “CANCELLED” and shall return the cancelled Irrevocable Standby Letter of Credit to the Bank with instructions to cancel the Irrevocable Standby Letter of Credit, and shall send to Generator a copy of such cancelled Irrevocable Standby Letter of Credit and instructions for cancellation, and (ii) return all cash deposit(s), if any, then held by TSP to Generator.

Per Exhibit “A” Section 8.3, TSP shall release the portion of the Security, and any renewed Security thereafter, for the new TSP Reata Station and associated transmission line

within (5) business days after TSP has received the notice from the Generator that the Plant has achieved Commercial Operation, and TSP has verified the same.

**Schematic of Lone Star Transmission, LLC System
in the Proximate Area of the Proposed Project**

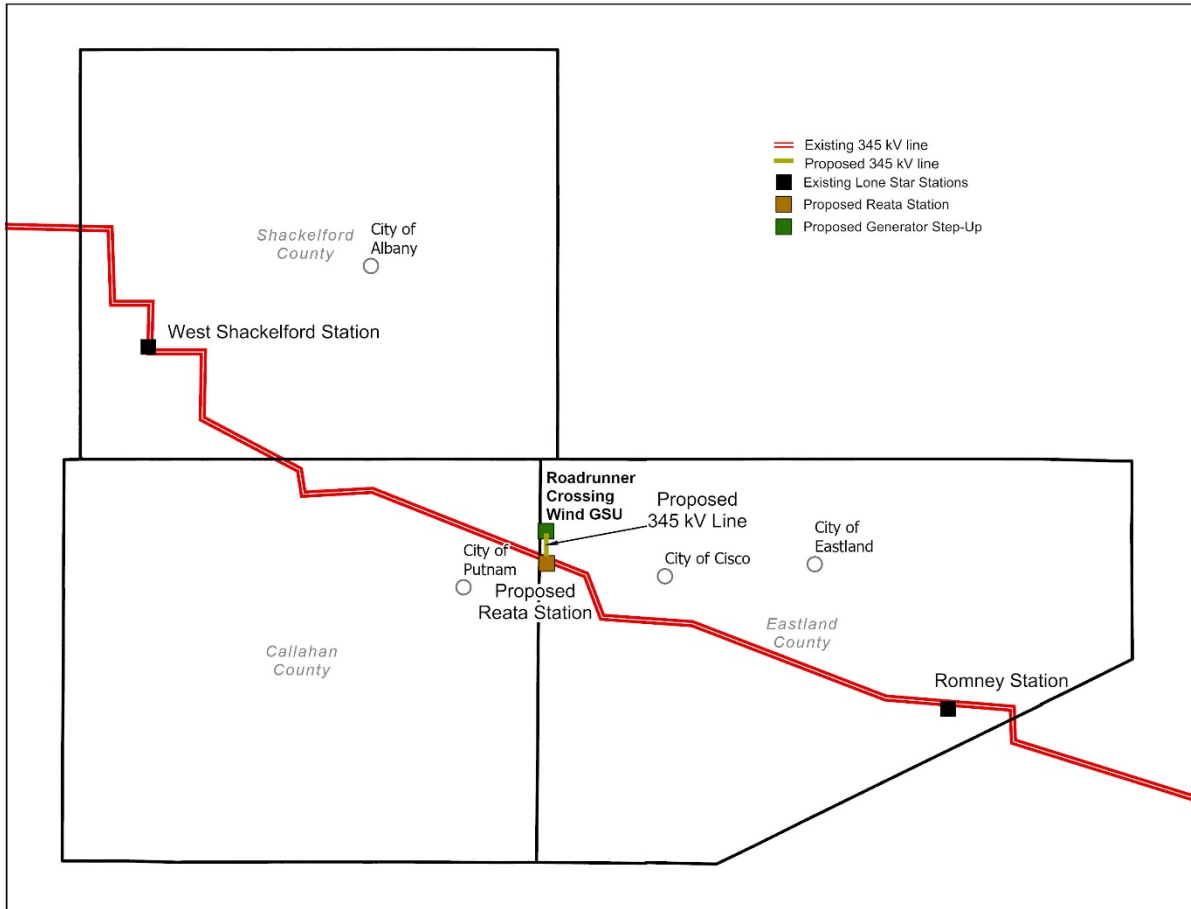

Proposed Roadrunner Crossing Wind Collector Station

Proposed Reata Station

Map ID	Landowner
1	TEB Land & Cattle LP
2	G & R Capital Properties LLC

- Project Endpoint
- Consensus Route
- Property Boundary
- Existing Transmission Line
- County Boundary
- County Road



0 1,000 2,000
1 inch = 1600 feet



Directly Affected Landowners
Reata Station to Roadrunner Crossing Wind
345 kV Transmission Line
Lone Star Transmission
Eastland County, Texas

Path: \\dalsrv\data\Projects\ESPLONE STAR TRANSMISSION\Roadrunner 345kV\Geospatial\DataFiles\ArcDocs\RX2RS_Directly_Affected.mxd gacox 5/21/2020

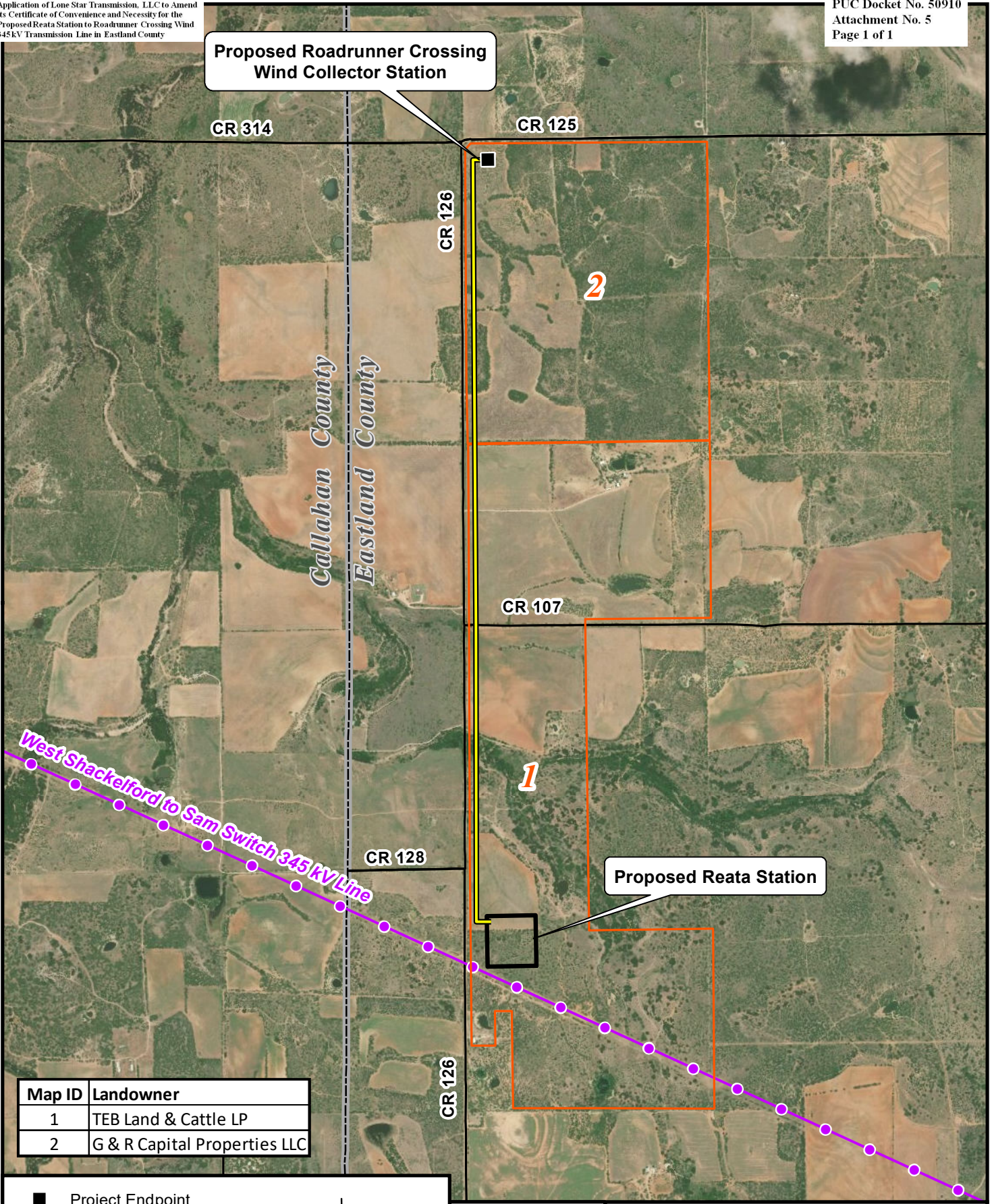

Landowner Names, Property Identification, and Map Locations
Cross-Reference Table

Map ID	Parcel ID(s)	Landowner Name	Address	City	State	Zip
1	3128, 2569, 50269	TEB Land & Cattle, LP	P.O. Box 588	Cisco	TX	76437
2	2565, 2502	G & R Capital Properties, LLC	807 Yellowstone Dr.	Mansfield	TX	76063



June 30, 2020

<Landowner Name>

<Address>

<City, State, Zip>

RE: PUC Docket No. 50910; *Application of Lone Star Transmission, LLC to Amend Its Certificate of Convenience and Necessity for the Proposed Reata Station to Roadrunner Crossing Wind 345 kV Transmission Line in Eastland County*

Dear [Landowner]:

Lone Star Transmission, LLC (Lone Star) gives notice of its intent to amend its Certificate of Convenience and Necessity (CCN) to construct a proposed 345 kV single-circuit transmission line in Eastland County, Texas. Lone Star has filed its application to amend its CCN with the Public Utility Commission of Texas (Commission or PUC) in Docket No. 50910 – *Application of Lone Star Transmission, LLC to Amend Its Certificate of Convenience and Necessity for the Proposed Reata Station to Roadrunner Crossing Wind 345 kV Transmission Line in Eastland County*.

Lone Star is filing a single routing option (Consensus Route) for this project. The new transmission line will be constructed between the new Reata 345 kV Station, which will be located east of County Road (CR) 126 and southeast of the CR 125 and CR 128 intersection, and the Roadrunner Crossing Wind Collector Station, which will be located southeast of the CR 125 and CR 126 intersection. The proposed Consensus Route is approximately 2.3 miles in length. The estimated cost of the transmission line is approximately \$3.4 million, and the estimated cost of the substation is approximately \$21.6 million. The project will be constructed using primarily concrete monopole structures.

Your land may be directly affected in this docket. If Lone Star's route is approved by the PUC, Lone Star will have the right to build a facility that may directly affect your land. The PUC docket will not determine the value of your land or the value of an easement if one is needed by the applicant to build the facility. If you have questions about the transmission line, you may contact Kelly Wells at (512) 236-3151 (office) or (512) 810-5561 (mobile).

A map illustrating Lone Star's Consensus Route is enclosed for your review. Also enclosed is a written description of the Consensus Route that has been filed with the Commission in the Lone Star CCN application. A detailed routing map may be downloaded from Lone Star's website at <http://www.lonestartransmission.com/reata-to-roadrunner/regulatory.html>.

June 30, 2020

Page 2

All routes and route segments included in this notice are available for selection and approval by the Public Utility Commission of Texas. Additionally, the PUC may modify any proposed route or segment into different configurations than those proposed.

The enclosed brochure entitled “Landowners and Transmission Line Cases at the PUC” provides basic information about how you may participate in this docket, and how you may contact the PUC. Please read this brochure carefully. The brochure includes sample forms for making comments and for making a request to intervene as a party in this docket. The PUC’s brochure emphasizes: *The only way to fully participate in the PUC’s decision on where to locate the transmission line is to intervene in the docket. It is important for an affected person to intervene because Lone Star is not obligated to keep affected persons informed of the PUC’s proceedings and cannot predict which route may or may not be approved by the PUC.*

In addition to the contacts listed in the brochure, you may call the PUC’s Customer Assistance Hotline at (888) 782-8477. Hearing- and speech-impaired individuals with text telephones (TTY) may contact the PUC’s Customer Assistance Hotline at (512) 936-7136 or toll free at (800) 735-2989. If you wish to participate in this proceeding by becoming an intervenor, the deadline for intervention in the proceeding is August 14, 2020, and the PUC should receive a letter from you requesting intervention by that date.

Due to the COVID-19 pandemic, the preferred method for you to file your request for intervention is electronically, and you will be required to serve the request on other parties by email. Therefore, please include your own email address on the intervention form. Instructions for electronic filing via the “PUC Filer” on the Commission’s website can be found here: <https://interchange.puc.texas.gov/filer>. Instructions for using the PUC Filer are available at http://www.puc.texas.gov/industry/filings/New_PUC_Web_Filer_Presentation.pdf. Once you obtain a tracking sheet associated with your filing from the PUC Filer, you may email the tracking sheet and the document you wish to file to: centralrecords@puc.texas.gov. For assistance with your electronic filing, please contact the Commission’s Help Desk at (512) 936-7100 or helpdesk@puc.texas.gov. You can review materials filed in this docket on the PUC Interchange at: <http://interchange.puc.texas.gov/>.

If you are unable to file your request for intervention electronically, you may file your request by mailing a hard copy to the PUC. The PUC should receive a letter from you requesting intervention by the intervention date (August 14, 2020). Mail the request for intervention and 10 copies of your request to:

Public Utility Commission of Texas
Central Records
Attn: Filing Clerk
1701 N. Congress Ave.
P.O. Box 13326
Austin, Texas 78711-3326

June 30, 2020

Page 3

Persons who wish to intervene in the docket must also mail a copy of their request for intervention to all parties in the docket and all persons that have pending motions to intervene, at or before the time the request for intervention is mailed to the PUC.

In addition to the intervention deadline, other important deadlines may already exist that affect your participation in this docket. You should review the orders and other filings already made in the docket. The enclosed brochure explains how you can access these filings.

Sincerely,



Kelly Wells
Director, Land Strategy and Community Relations
Lone Star Transmission, LLC
Office: (512) 236-3151
Mobile: (512) 810-5561
Email: kelly.wells@lonestar-transmission.com

Enclosures:

- Map of Consensus Route
- Consensus Route Description
- Landowner Brochure
- Comment/Protest Form
- Intervenor Form

Path: \\dalsrv\data\Projects\ESP\LONE STAR TRANSMISSION\Roadrunner 345kV\Geospatial\DataFiles\ArcDocs\RX2RS_Notice_Map.mxd gacox 5/21/2020

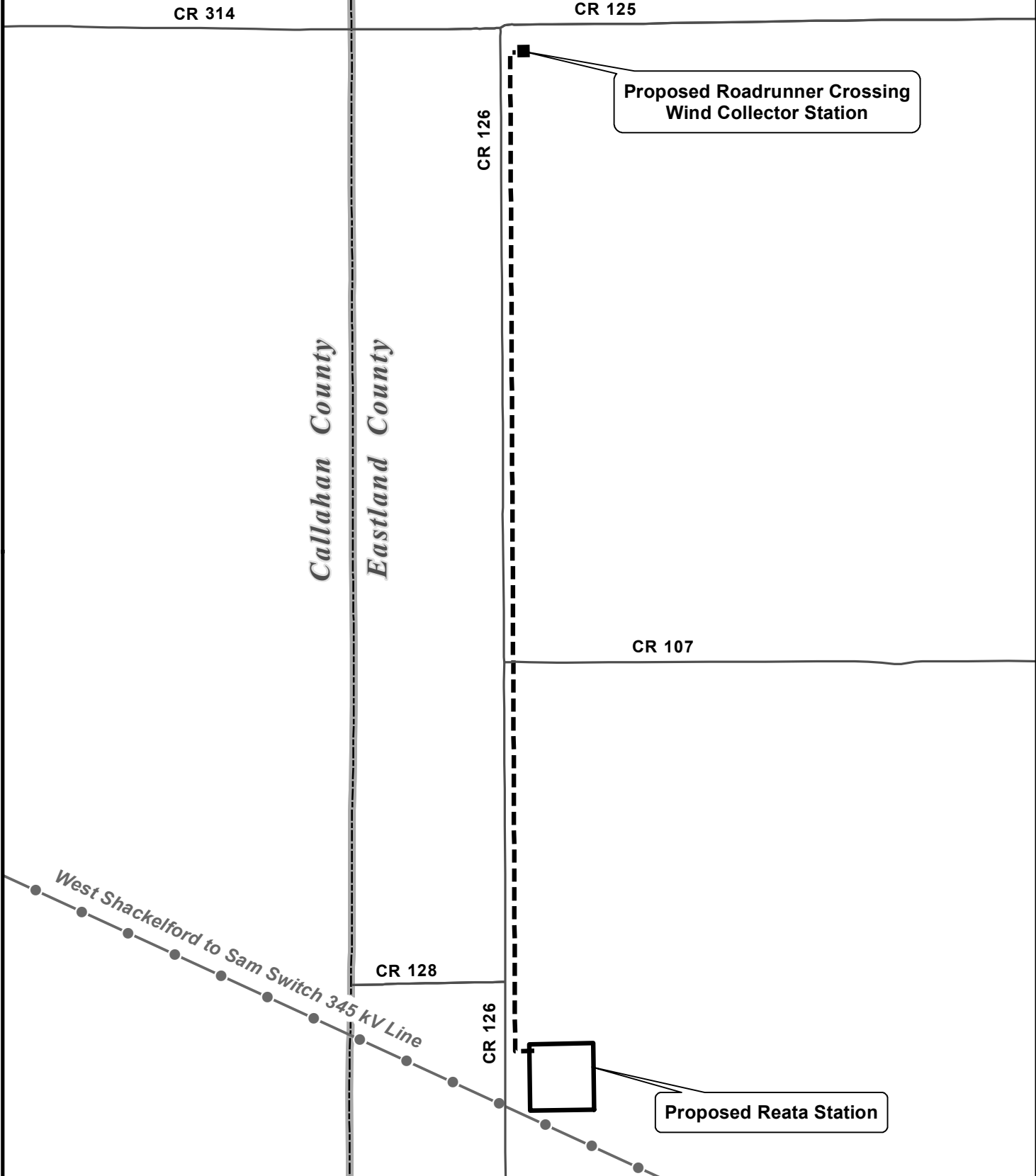

- Project Endpoint
- - - Consensus Route
- Existing Transmission Line
- - - County Boundary
- County Road

0 800 1,600
 1 inch = 1600 feet

Reata Station to
 Roadrunner Crossing Wind
 345 kV Transmission Line
 Lone Star Transmission
 Eastland County, Texas

**Reata Station to Roadrunner Crossing Wind 345 kV Transmission Line Project
Consensus Route Description**

The Consensus Route (Route) originates on the northwest corner of Lone Star Transmission, LLC's (Lone Star) proposed Reata 345 kilovolt (kV) Station, located on the north side of Lone Star's existing West Shackelford to Sam Switch 345 kV Transmission Line and east of County Road (CR) 126, approximately 865 feet southeast of the CR 125 and CR 128 intersection in Eastland County, Texas. It proceeds west approximately 230 feet to the east side of CR 126 and turns north. From there the Route parallels the east side of CR 126 to the north for approximately 4,580 where it crosses CR 107. The Route then continues to parallel the east side of CR 126 to the north an additional 7,166 feet to a point approximately 300 feet southeast of the CR 125 and CR 126 intersection, where it turns east. The Route proceeds approximately 165 feet to the east and terminates at the proposed Roadrunner Crossing Wind 345 kV Collector Station.

Landowners and Transmission Line Cases at the PUC

Public Utility Commission of Texas



1701 N. Congress Avenue
P.O. Box 13326
Austin, Texas 78711-3326
(512) 936-7260
www.puc.state.tx.us

Effective: June 1, 2011

Purpose of This Brochure

This brochure is intended to provide landowners with information about proposed new transmission lines and the Public Utility Commission's ("PUC" or "Commission") process for evaluating these proposals. At the end of the brochure is a list of sources for additional information.

The following topics are covered in this brochure:

- How the PUC evaluates whether a new transmission line should be built,
- How you can participate in the PUC's evaluation of a line, and
- How utilities acquire the right to build a transmission line on private property.

You are receiving the enclosed formal notice because one or more of the routes for a proposed transmission line may require an easement or other property interest across your property, or the centerline of the proposed project may come within 300 feet of a house or other habitable structure on your property. This distance is expanded to 500 feet if the proposed line is greater than 230 kilovolts (kV). For this reason, your property is considered **directly affected land**. This brochure is being included as part of the formal notice process.

If you have questions about the proposed routes for a transmission line, you may contact the applicant. The applicant also has a more detailed map of the proposed routes for the transmission line and nearby habitable structures. The applicant may help you understand the routing of the project and the application approval process in a transmission line case but cannot provide legal advice or represent you. ***The applicant cannot predict which route may or may not be approved by the PUC. The PUC decides which route to use for the transmission line, and the applicant is not obligated to keep you informed of the PUC's proceedings. The only way to fully participate in the PUC's decision on where to locate the transmission line is to intervene, which is discussed below.***

The PUC is sensitive to the impact that transmission lines have on private property. At the same time, transmission lines deliver electricity to millions of homes and businesses in Texas, and new lines are sometimes needed so that customers can obtain reliable, economical power.

The PUC's job is to decide whether a transmission line application should be approved and on which route the line should be constructed. The PUC values input from landowners and encourages you to participate in this process by intervening in the docket.

PUC Transmission Line Case

Texas law provides that most utilities must file an application with the PUC to obtain or amend a Certificate of Convenience and Necessity (CCN) in order to build a new transmission line in Texas. The law requires the PUC to consider a number of factors in deciding whether to approve a proposed new transmission line.

The PUC may approve an application to obtain or amend a CCN for a transmission line after considering the following factors:

- Adequacy of existing service;
- Need for additional service;
- The effect of approving the application on the applicant and any utility serving the proximate area;
- Whether the route utilizes existing compatible rights-of-way, including the use of vacant positions on existing multiple-circuit transmission lines;
 - Whether the route parallels existing compatible rights-of-way;
 - Whether the route parallels property lines or other natural or cultural features;
 - Whether the route conforms with the policy of prudent avoidance (which is defined as the limiting of exposures to electric and magnetic fields that can be avoided with reasonable investments of money and effort); and
 - Other factors such as community values, recreational and park areas, historical and aesthetic values, environmental integrity, and the probable improvement of service or lowering of cost to consumers in the area.

If the PUC decides an application should be approved, it will grant to the applicant a CCN or CCN amendment to allow for the construction and operation of the new transmission line.

Application to Obtain or Amend a CCN:

An application to obtain or amend a CCN describes the proposed line and includes a statement from the applicant describing the need for the line and the impact of building it. In addition to the routes proposed by the applicant in its application, the possibility exists that additional routes may be developed, during the course of a CCN case, that could affect property in a different manner than the original routes proposed by the applicant.

The PUC conducts a case to evaluate the impact of the proposed line and to decide which route should be approved. Landowners who would be affected by a new line can:

- informally file a protest, or
- formally participate in the case as an intervenor.

Filing a Protest (informal comments):

If you do not wish to intervene and participate in a hearing in a CCN case, you may file **comments**. An individual or business or a group who files only comments for or against any aspect of the transmission line application is considered a “protestor.”

Protestors make a written or verbal statement in support of or in opposition to the utility’s application and give information to the PUC staff that they believe supports their position.

Protestors are **not** parties to the case, however, and do not have the right to:

- Obtain facts about the case from other parties;
- Receive notice of a hearing, or copies of testimony and other documents that are filed in the case;
- Receive notice of the time and place for negotiations;
- File testimony and/or cross-examine witnesses;
- Submit evidence at the hearing; or
- Appeal P.U.C. decisions to the courts.

If you want to make comments, you may either send written comments stating your position, or you may make a statement on the first day of the hearing. If you have not intervened, however, you will not be able to participate as a party in the hearing. Only parties may submit evidence and ***the PUC must base its decision on the evidence.***

Intervening in a Case:

To become an intervenor, you must file a statement with the PUC, no later than the date specified in the notice letter sent to you with this brochure, requesting intervenor status (also referred to as a party). This statement should describe how the proposed transmission line would affect your property. Typically, intervention is granted only to directly affected landowners. However, any landowner may request to intervene and obtain a ruling on his or her specific fact situation and concerns. A sample form for intervention and the filing address are attached to this brochure, and may be used to make your filing. A letter requesting intervention may also be used in lieu of the sample form for intervention.

If you decide to intervene and become a party in a case, you will be required to follow certain procedural rules:

- You are required to timely respond to requests for information from other parties who seek information.
- If you file testimony, you must appear at a hearing to be cross-examined.
- If you file testimony or any letters or other documents in the case, you must send copies of the documents to every party in the case and you must file multiple copies with the PUC.

If you intend to participate at the hearing and you do not file testimony, you must at least file a statement of position, which is a document that describes your position in the case.

Failure to comply with these procedural rules may serve as grounds for you to be dismissed as an intervenor in the case.

If you wish to participate in the proceedings it is very important to attend any prehearing conferences.

Intervenors may represent themselves or have an attorney to represent them in a CCN case. If you intervene in a case, you may want an attorney to help you understand the PUC’s procedures and the laws and rules that the PUC applies in deciding whether to approve a transmission line. The PUC encourages landowners to intervene and become parties.

Stages of a CCN Case:

If there are persons who intervene in the case and oppose the approval of the line, the PUC may refer the case to an administrative law judge (ALJ) at the State Office of Administrative Hearings (SOAH) to conduct a hearing, or the Commission may elect to conduct a hearing itself. The hearing is a formal proceeding, much like a trial, in which testimony is presented. In the event the case is referred to SOAH, the ALJ makes a recommendation to the PUC on whether the application should be approved and where and how the line should be routed.

There are several stages of a CCN case:

- The ALJ holds a prehearing conference (usually in Austin) to set a schedule for the case.
- Parties to the case have the opportunity to conduct discovery; that is, obtain facts about the case from other parties.
- A hearing is held (usually in Austin), and parties have an opportunity to cross-examine the witnesses.
- Parties file written testimony before the date of the hearing. Parties that do not file written testimony or statements of position by the deadline established by the ALJ may not be allowed to participate in the hearing on the merits. Parties may file written briefs concerning the evidence presented at the hearing, but are not required to do so.

In deciding where to locate the transmission line and other issues presented by the application, the ALJ and Commission rely on factual information submitted as evidence at the hearing by the parties in the case. In order to submit factual information as evidence (other than through cross-examination of other parties' witnesses), a party must have intervened in the docket and filed written testimony on or before the deadline set by the ALJ.

The ALJ makes a recommendation, called a **proposal for decision**, to the Commission regarding the case. Parties who disagree with the ALJ's recommendation may file exceptions.

The Commissioners discuss the case and decide whether to approve the application. The Commission may approve the ALJ's recommendation, approve it with specified changes, send the case back to the ALJ for further consideration, or deny the application. The written decision rendered by the Commission is called a **final order**. Parties who believe that the Commission's decision is in error may file motions for rehearing, asking the Commission to reconsider the decision.

After the Commission rules on the motion for rehearing, parties have the right to appeal the decision to district court in Travis County.

Right to Use Private Property

The Commission is responsible for deciding whether to approve a CCN application for a proposed transmission line. If a transmission line route is approved that impacts your property, the electric utility must obtain the right from you to enter your property and to build, operate, and maintain the transmission line. This right is typically called an easement.

Utilities may buy easements through a negotiated agreement, but they also have the power of eminent domain (condemnation) under Texas law. Local courts, not the PUC, decide issues concerning easements for rights-of-way. The PUC does not determine the value of property.

The PUC final order in a transmission case normally requires a utility to take certain steps to minimize the impact of the new transmission line on landowners' property and on the environment. For example, the order normally requires steps to minimize the possibility of erosion during construction and maintenance activities.

HOW TO OBTAIN MORE INFORMATION

The PUC's online filings interchange on the PUC website provides free access to documents that are filed with the Commission in Central Records. The docket number, also called a control number on the PUC website, of a case is a key piece of information used in locating documents in the case. You may access the Interchange by visiting the PUC's website home page at www.puc.state.tx.us and navigate the website as follows:

- Select "Filings."
Select "Filings Search."
Select "Filings Search."
Enter 5-digit Control (Docket) Number. *No other information is necessary.*
Select "Search." *All of the filings in the docket will appear in order of date filed.*
Scroll down to select desired filing.
Click on a blue "Item" number at left.
Click on a "Download" icon at left.

Documents may also be purchased from and filed in Central Records. For more information on how to purchase or file documents, call Central Records at the PUC at 512-936-7180.

PUC Substantive Rule 25.101, Certification Criteria, addresses transmission line CCNs and is available on the PUC's website, or you may obtain copies of PUC rules from Central Records.

Always include the docket number on all filings with the PUC. You can find the docket number on the enclosed formal notice. Send documents to the PUC at the following address.

Public Utility Commission of Texas
Central Records
Attn: Filing Clerk
1701 N. Congress Avenue
P.O. Box 13326
Austin, TX 78711-3326

The information contained within this brochure is not intended to provide a comprehensive guide to landowner rights and responsibilities in transmission line cases at the PUC. This brochure should neither be regarded as legal advice nor should it be a substitute for the PUC's rules. However, if you have questions about the process in transmission line cases, you may call the PUC's Legal Division at 512-936-7260. The PUC's Legal Division may help you understand the process in a transmission line case but cannot provide legal advice or represent you in a case. You may choose to hire an attorney to decide whether to intervene in a transmission line case, and an attorney may represent you if you choose to intervene.

Communicating with Decision-Makers

Do not contact the ALJ or the Commissioners by telephone or email. They are not allowed to discuss pending cases with you. They may make their recommendations and decisions only by relying on the evidence, written pleadings, and arguments that are presented in the case.

Comments in Docket No. 50910

If you want to be a PROTESTOR only, please complete this form. Although public comments are not treated as evidence, they help inform the PUC and its staff of the public concerns and identify issues to be explored. The PUC welcomes such participation in its proceedings.

Mail this completed form and 10 copies to:

Public Utility Commission of Texas
Central Records
Attn: Filing Clerk
1701 N. Congress Ave.
P.O. Box 13326
Austin, TX 78711-3326

First Name: _____ Last Name: _____

Phone Number: _____ Fax Number: _____

Address, City, State: _____

I am NOT requesting to intervene in this proceeding. As a PROTESTOR, I understand the following:

- I am NOT a party to this case;
- My comments are not considered evidence in this case; and
- I have no further obligation to participate in the proceeding.

Please check one of the following:

- I own property with a habitable structure located near one or more of the utility's proposed routes for a transmission line.
- One or more of the utility's proposed routes would cross my property.
- Other. Please describe and provide comments. You may attach a separate page, if necessary. _____

Signature of person submitting comments:

_____ Date: _____

Request to Intervene in PUC Docket No. 50910

The following information must be submitted by the person requesting to intervene in this proceeding. This completed form will be provided to all parties in this docket. **If you DO NOT want to be an intervenor, but still want to file comments, please complete the "Comments" page.**

Mail this completed form and 10 copies to:

Public Utility Commission of Texas
Central Records
Attn: Filing Clerk
1701 N. Congress Ave.
P.O. Box 13326
Austin, TX 78711-3326

First Name: _____ Last Name: _____

Phone Number: _____ Fax Number: _____

Address, City, State: _____

Email Address: _____

I am requesting to intervene in this proceeding. As an INTERVENOR, I understand the following:

- I am a party to the case;
- I am required to respond to all discovery requests from other parties in the case;
- If I file testimony, I may be cross-examined in the hearing;
- If I file any documents in the case, I will have to provide a copy of that document to every other party in the case; and
- I acknowledge that I am bound by the Procedural Rules of the Public Utility Commission of Texas (PUC) and the State Office of Administrative Hearings (SOAH).

Please check one of the following:

- I own property with a habitable structure located near one or more of the utility's proposed routes for a transmission line.
- One or more of the utility's proposed routes would cross my property.
- Other. Please describe and provide comments. You may attach a separate page, if necessary.

Signature of person requesting intervention:

_____ Date: _____

List of Directly Affected Landowners Receiving Notice

Map ID	Parcel ID(s)	Landowner Name	Address	City	State	Zip
1	3128, 2569, 50269	TEB Land & Cattle, LP	P.O. Box 588	Cisco	TX	76437
2	2565, 2502	G & R Capital Properties, LLC	807 Yellowstone Dr.	Mansfield	TX	76063

List of Utilities Receiving Notice of Application

AEP Texas Inc.

Gilbert Hughes
Director, Regulatory Services
American Electric Power, Inc.
400 West 15th Street, Suite 1520
Austin, Texas 78701

Comanche County Electric Cooperative Association

Alan Lesley
General Manager
Comanche County Electric Cooperative Association
P.O. Box 729
Comanche, Texas 76442



June 30, 2020

<Name>
<Title>
<Utility Provider Name >
<Address>
<City, State, Zip>

RE: PUC Docket No. 50910; *Application of Lone Star Transmission, LLC to Amend Its Certificate of Convenience and Necessity for the Proposed Reata Station to Roadrunner Crossing Wind 345 kV Transmission Line in Eastland County*

Dear [Contact Name]:

Lone Star Transmission, LLC (Lone Star) gives notice of its intent to amend its Certificate of Convenience and Necessity (CCN) to construct a proposed 345 kV single-circuit transmission line in Eastland County, Texas. Lone Star has filed its application to amend its CCN with the Public Utility Commission of Texas (Commission or PUC) in Docket No. 50910 – *Application of Lone Star Transmission, LLC to Amend Its Certificate of Convenience and Necessity for the Proposed Reata Station to Roadrunner Crossing Wind 345 kV Transmission Line in Eastland County*.

Lone Star is filing a single routing option (Consensus Route) for this project that is approximately 2.3 miles in length. The estimated cost of the transmission line is approximately \$3.4 million, and the estimated cost of the substation is approximately \$21.6 million. The project will be constructed using primarily concrete monopole structures.

A map illustrating Lone Star's proposed Consensus Route is enclosed for your review. Also enclosed is a written description of the Consensus Route that has been filed with the Commission in the Lone Star CCN application. A detailed routing map may be downloaded from Lone Star's website at <http://www.lonestartransmission.com/reata-to-roadrunner/regulatory.html>.

If you have questions about this transmission line project or Lone Star's CCN application, you may contact Lone Star's representative, Kelly Wells at (512) 236-3151 (office) or (512) 810-5561 (mobile).

Persons who wish to intervene in the proceeding or comment upon the action must submit a request to intervene to the PUC. The deadline for intervention in the proceeding is August 14, 2020, and a letter requesting intervention should be received by the PUC by that date.

June 30, 2020

Page 2

Due to the COVID-19 pandemic, the preferred method for you to file your request for intervention is electronically, and you will be required to serve the request on other parties by email. Therefore, please include your own email address on the intervention form. Instructions for electronic filing via the “PUC Filer” on the Commission’s website can be found here: <https://interchange.puc.texas.gov/filer>. Instructions for using the PUC Filer are available at http://www.puc.texas.gov/industry/filings/New_PUC_Web_Filer_Presentation.pdf. Once you obtain a tracking sheet associated with your filing from the PUC Filer, you may email the tracking sheet and the document you wish to file to: centralrecords@puc.texas.gov. For assistance with your electronic filing, please contact the Commission’s Help Desk at (512) 936-7100 or helpdesk@puc.texas.gov. You can review materials filed in this docket on the PUC Interchange at: <http://interchange.puc.texas.gov/>.

If you are unable to file your request for intervention electronically, you may file your request for intervention by mailing a hard copy of your request to the PUC. The PUC should receive your request to intervene by the intervention date (August 14, 2020). Mail the request for intervention (along with 10 copies of the request) to the following address:

Public Utility Commission of Texas
Central Records
Attn: Filing Clerk
1701 N. Congress Ave.
P.O. Box 13326
Austin, Texas 78711-3326

All routes and routing links included in this notice are available for selection and approval by the Public Utility Commission of Texas.

The Commission has developed a brochure titled “Landowners and Transmission Line Cases at the PUC.” Copies of the brochure are available from Lone Star by calling Kelly Wells or may be downloaded from the PUC’s website at <http://puc.texas.gov>. To obtain additional information about this case, contact the PUC at (512) 936-7120 or toll free at (888) 782-8477. Hearing- and speech-impaired individuals with text telephones (TTY) may contact the PUC at (512) 936-7136 or toll free at (800) 735-2989.

Sincerely,



Kelly Wells
Director, Land Strategy and Community Relations
Lone Star Transmission, LLC
Office: (512) 236-3151
Mobile: (512) 810-5561

June 30, 2020

Page 3

Email: kelly.wells@lonestar-transmission.com

Enclosures:

- Map of Consensus Route
- Consensus Route Description

List of Public Officials Receiving Notice of Application

Eastland County Officials

The Honorable Rex Fields
Eastland County Judge
100 W. Main, Suite 203
Eastland, TX 76448

Andy Maxwell
Eastland County Precinct 1 Commissioner
Commissioners Court
100 W. Main, Suite 203
Eastland, TX 76448

James Crenshaw
Eastland County Precinct 2 Commissioner
Commissioners Court
100 W. Main, Suite 203
Eastland, TX 76448

Ronnie Wilson
Eastland County Precinct 3 Commissioner
Commissioners Court
100 W. Main, Suite 203
Eastland, TX 76448

Robert Rains
Eastland County Precinct 4 Commissioner
Commissioners Court
100 W. Main, Suite 203
Eastland, TX 76448

Department of Defense Siting Clearinghouse

Department of Defense Siting Clearinghouse
3400 Defense Pentagon
Room 5C646
Washington, D.C. 20301-3400
osd.dod-siting-clearinghouse@mail.mil

**Application of Lone Star Transmission, LLC to Amend
Its Certificate of Convenience and Necessity for the
Proposed Reata Station to Roadrunner Crossing Wind
345 kV Transmission Line in Eastland County**

**PUC Docket No. 50910
Attachment No. 9
Page 2 of 4**

Office of Public Utility Counsel

The Honorable Lori Cobos
Office of Public Utility Counsel
P.O. Box 12397
Austin, Texas 78711-2397



June 30, 2020

<Office Holder Name, County/City or DoD or OPUC>

<Address>

<City, State, Zip>

RE: PUC Docket No. 50910; *Application of Lone Star Transmission, LLC to Amend Its Certificate of Convenience and Necessity for the Proposed Reata Station to Roadrunner Crossing Wind 345 kV Transmission Line in Eastland County*

Dear [Contact Name]:

Lone Star Transmission, LLC (Lone Star) gives notice of its intent to amend its Certificate of Convenience and Necessity (CCN) to construct a proposed 345 kV single-circuit transmission line in Eastland County, Texas. Lone Star has filed its application to amend its CCN with the Public Utility Commission of Texas (Commission or PUC) in Docket No. 50910 – *Application of Lone Star Transmission, LLC to Amend Its Certificate of Convenience and Necessity for the Proposed Reata Station to Roadrunner Crossing Wind 345 kV Transmission Line in Eastland County*.

Lone Star is filing a single routing option (Consensus Route) for this project that is approximately 2.3 miles in length. The estimated cost of the transmission line is approximately \$3.4 million, and the estimated cost of the substation is approximately \$21.6 million. The project will be constructed using primarily concrete monopole structures.

A map illustrating Lone Star’s proposed Consensus Route is enclosed for your review. Also enclosed is a written description of the Consensus Route that has been filed with the Commission in the Lone Star CCN application. A detailed routing map may be downloaded from Lone Star’s website at <http://www.lonestartransmission.com/reata-to-roadrunner/regulatory.html>.

If you have questions about this transmission line project or Lone Star’s CCN application, you may contact Lone Star’s representative, Kelly Wells at (512) 236-3151 (office) or (512) 810-5561 (mobile).

Due to the COVID-19 pandemic, the preferred method for you to file your request for intervention is electronically, and you will be required to serve the request on other parties by email. Therefore, please include your own email address on the intervention form. Instructions for electronic filing via the “PUC Filer” on the Commission’s website can be found here: <https://interchange.puc.texas.gov/filer>. Instructions for using the PUC Filer are available at http://www.puc.texas.gov/industry/filings/New_PUC_Web_Filer_Presentation.pdf. Once you obtain a tracking sheet associated with your filing from the PUC Filer, you may email the tracking sheet and the document you wish to file to: centralrecords@puc.texas.gov. For assistance with your electronic filing, please contact the Commission’s Help Desk at (512) 936-

Addressee First Name Last Name

June 30, 2020

Page 2

7100 or helpdesk@puc.texas.gov. You can review materials filed in this docket on the PUC Interchange at: <http://interchange.puc.texas.gov/>.

If you are unable to file your request for intervention electronically, you may file your request for intervention by mailing a hard copy of your request to the PUC. The PUC should receive your request to intervene by the intervention date (August 14, 2020). Mail the request for intervention (along with 10 copies of the request) to the following address:

Public Utility Commission of Texas
Central Records, Attn: Filing Clerk
1701 N. Congress Avenue
P.O. Box 13326
Austin, Texas 78711-3326

All routes and route segments included in this notice are available for selection and approval by the Public Utility Commission of Texas.

The Commission has developed a brochure titled “Landowners and Transmission Line Cases at the PUC.” Copies of the brochure are available from Lone Star by calling Kelly Wells or may be downloaded from the PUC’s website at <http://puc.texas.gov>. To obtain additional information about this case, contact the PUC at (512) 936-7120 or toll free at (888) 782-8477. Hearing- and speech-impaired individuals with text telephones (TTY) may contact the PUC at (512) 936-7136 or toll free at (800) 735-2989.

Sincerely,



Kelly Wells
Director, Land Strategy and Community Relations
Lone Star Transmission, LLC
Office: (512) 236-3151
Mobile: (512) 810-5561
Email: kelly.wells@lonestar-transmission.com

Enclosures:

- Map of Consensus Route
- Consensus Route Description
- Comment/Protest Form
- Intervenor Form

Newspaper Publication List

Notice of the CCN Application will be published in the following newspaper of general circulation in Eastland County:

Eastland County Today Cisco Press
Eastland County Newspapers
215 S. Seaman
Eastland, Texas 76448

PUBLIC NOTICE

Application of Lone Star Transmission, LLC to Amend its Certificate of Convenience and Necessity for the Reata Station to Roadrunner Crossing Wind 345 kV Transmission Line in Eastland County, Texas

PUBLIC UTILITY COMMISSION OF TEXAS (PUC) DOCKET NO. 50910

Lone Star Transmission, LLC (Lone Star) gives notice that it is requesting approval from the Public Utility Commission of Texas (PUC) to amend its Certificate of Convenience and Necessity (CCN) to construct the Reata Station to Roadrunner Crossing Wind 345 kV Transmission Line in Eastland County, Texas. Lone Star has filed an application with the PUC for this purpose in Docket No. 50910.

Lone Star is filing a single routing option (Consensus Route) for this project that is approximately 2.3 miles in length. The estimated cost of the transmission line is approximately \$3.4 million, and the estimated cost of the substation is approximately \$21.6 million. The project will be constructed using primarily concrete monopole structures.

All routes and route segments included in this notice are available for selection and approval by the Public Utility Commission of Texas.

Persons who are affected by the transmission line and wish to intervene in the docket or comment on the applicant's application should submit a request for intervention or comments to the PUC. Due to the COVID-19 pandemic, the preferred method for you to file your request for intervention or comments is electronically, and you will be required to serve the request on other parties by email. Therefore, please include your own email address on the intervention form. Instructions for electronic filing via the "PUC Filer" on the Commission's website can be found here: <https://interchange.puc.texas.gov/filer>. Instructions for using the PUC Filer are available at http://www.puc.texas.gov/industry/filings/New_PUC_Web_Filer_Presentation.pdf. Once you obtain a tracking sheet associated with your filing from the PUC Filer, you may email the tracking sheet and the document you wish to file to: centralrecords@puc.texas.gov. For assistance with your electronic filing, please contact the Commission's Help Desk at (512) 936-7100 or helpdesk@puc.texas.gov. You can review materials filed in this docket on the PUC Interchange at: <http://interchange.puc.texas.gov/>.

If you are unable to file your request for intervention or comments electronically, you may file your request for intervention or comments by mailing the original and 10 copies to:

Public Utility Commission of Texas
Central Records
Attn: Filing Clerk
1701 N. Congress Ave.
P.O. Box 13326
Austin, Texas 78711-3326

The deadline for intervention in the docket is August 14, 2020, and the PUC should receive a letter from anyone requesting intervention by that date.

Persons who wish to intervene in the docket must also mail a copy of their request for intervention to all parties in the docket and all persons that have pending motions to intervene, at or before the time the request for intervention is mailed to the PUC. In addition to the intervention deadline, other important deadlines may already exist that affect your participation in this docket. You should review the orders and other filings already made in the docket.

The only way to fully participate in the PUC's decision on where to locate the transmission line is to intervene in the docket. It is important for an affected person to intervene because the utility is not obligated to keep affected persons informed of the PUC's proceedings and cannot predict which route may or may not be approved by the PUC.

The PUC has a brochure entitled "Landowners and Transmission Line Cases at the PUC," which provides basic information about how you may participate in this docket and how you may contact the PUC. Copies of the brochure are available from Kelly Wells at (512) 236-3151 or may be downloaded from the PUC's website at <http://puc.texas.gov>. The brochure includes sample forms for making comments and for making a request to intervene as a party in this docket. In addition to the contacts listed in the brochure, you may call the PUC's Customer Assistance Hotline at (888) 782-8477. Hearing- and speech-impaired individuals with text telephones (TTY) may contact the PUC's Customer Assistance Hotline at (512) 936-7136 or toll free at (800) 735-2989.

A detailed routing map may be downloaded from Lone Star's website at <http://www.lonestartransmission.com/reata-to-roadrunner/regulatory.html>.

If you have questions about the transmission line, you may contact Lone Star representative Kelly Wells at (512) 236-3151.

Consensus Route Description

For this project as previously stated, only a Consensus Route is filed in Lone Star's CCN. The following narrative, along with the map that follows that shows the route, provides a detailed description of the Consensus Route. The Consensus Route originates on the northwest corner of Lone Star's proposed Reata 345 kV Station, located on the north side of Lone Star's existing West Shackelford to Sam Switch 345 kV transmission line and east of County Road (CR) 126, approximately 865 feet southeast of the CR 125 and CR 128 intersection in Eastland County, Texas. The Consensus Route proceeds west approximately 230 feet to the east side of CR 126 and turns north. From there the Consensus Route parallels the east side of CR 126 to the north for approximately 4,580 where it crosses CR 107. The Consensus Route then continues to parallel the east side of CR 126 to the north an additional 7,166 feet to a point approximately 300 feet southeast of the CR 125 and CR 126 intersection, where it turns east. The Consensus Route proceeds approximately 165 feet to the east and terminates at the Proposed Roadrunner Crossing Wind Collector Station.



June 30, 2020

Wildlife Habitat Assessment Program
Wildlife Division
Texas Parks and Wildlife Department
4200 Smith School Road
Austin, Texas 78744

RE: PUC Docket No. 50910; *Application of Lone Star Transmission, LLC to Amend Its Certificate of Convenience and Necessity for the Proposed Reata Station to Roadrunner Crossing Wind 345 kV Transmission Line in Eastland County*

Lone Star Transmission, LLC (Lone Star) gives notice that it has filed an application with the Public Utility Commission of Texas (PUC) to amend its Certificate of Convenience and Necessity (CCN) in the above-referenced docket. In its Application, Lone Star proposes to construct a 345 kV single-circuit transmission line and new 345 kV station in Eastland County, Texas. Lone Star is filing a single routing option (Consensus Route) for this project that is approximately 2.3 miles in length.

I have enclosed a copy of Lone Star's CCN Application for this project. In accordance with the requirements of 16 Texas Administrative Code (TAC) § 22.52 and the PUC's CCN Application form, the *Environmental Assessment* for this project is included for your review as Attachment 1 of the CCN Application.

If you have questions about this project or Lone Star's Application, you may contact me at (512) 236-3151 (office) or (512) 810-5561 (mobile).

Sincerely,

A handwritten signature in blue ink that reads "Kelly Wells".

Kelly Wells
Director, Land Strategy and Community Relations
Lone Star Transmission, LLC
Office: (512) 236-3151
Mobile: (512) 810-5561
Email: kelly.wells@lonestar-transmission.com

Enclosures:

- Lone Star's CCN Application and Environmental Assessment

Lone Star Transmission, LLC

5920 West William Cannon Drive, Building 2, Austin, Texas 78749

AFFIDAVIT

STATE OF TEXAS

COUNTY OF TRAVIS

I, Stacie Bennett, being duly sworn, file this application as Director, Regulatory Affairs for Lone Star Transmission, LLC (Lone Star), that, in such capacity, I am qualified and authorized on behalf of Lone Star to file and verify such application, am personally familiar with the maps and attachments filed with this application, and have complied with all the requirements contained in the application; and that all statements made and matters set forth therein and all attachments thereto are true and correct. I further state that the application is made in good faith and that this application does not duplicate any filing presently before the Public Utility Commission of Texas.

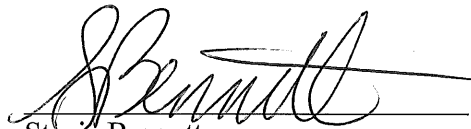

Stacie Bennett
Director, Regulatory Affairs
Lone Star Transmission, LLC

SUBSCRIBED AND SWORN TO BEFORE ME,

a Notary Public in and for the State of Texas, this

the 24th day of June, 2020.

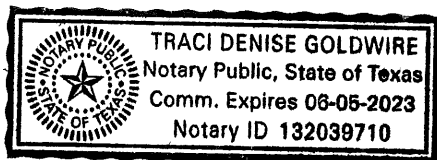

Notary Public State of Texas

My Commission Expires: June 5, 2023